

### Lista de peças / Parts lists / Lista de piezas

REF	DESC	COMP	LARG	ESP	QTD.
VE2904-01	LATERAL DIREITA/LADO DERECHO/RIGHT SIDE	1830	497	15	1
VE2904-02	LATERAL ESQUERDA/LADO IZQUIERDO/LEFT SIDE	1830	497	15	1
VE2904-03	BASE/BASE/BASE	497	598	15	1
VE2904-04	PRATELEIRA/ESTANTE/SHELF	497	598	15	2
VE2904-06	TRAVESSA FRONTAL/BANDEJA FRONTA/FRONT TRAY	598	70	15	1
VE2904-11	PORTA/PUERTA/DOOR	308	1145	15	2
VE2904-12	PORTA/PUERTA/DOOR	308	605	15	2
VE2904-24	PRATELEIRA/ESTANTE/SHELF	396	598	15	3
VE2904-26	TRAVESSA TRASERA/BANDEJA TRASERA/REAR TRAY	598	70	15	1
VE2904-61	COSTA/FONDO/BACK	620	204	3	3
VE2904-62	COSTA/FONDO/BACK	620	383	3	3

REF	DESC	QTD.
A	CAVILHA Ø6X30 CLAVIJA Ø6X30 WOOD DOWEL Ø6X30	12
B	PARAFUSO CC 4X14 TORNILLO CC 4X14 SCREW CC 4X14	50
C	PARAFUSO CC 4X40 TORNILLO CC 4X40 SCREW CC 4X40	28
F	PARAFUSO CF 4,5X50 TORNILLO CF 4,5X50 SCREW CF 4,5X50	05
R	FIXADOR COSTAS FIJADOR PRARA FONDO	08
M	PREGO 10X10 CLAVO 10X10 NAIL	75
DB	DOBRADIÇA 26 CALÇO 1 BISAGRA HINGE	10
U	ADESIVO TAPA FURO STICKER	20
G	SUPORTE FIXAÇÃO SOPORTE DE FIJACIÓN FIXING SUPPORT	01
H	PROTEÇÃO SUP CANTONEIRA PROTECCIÓN ANGLE BRACKET	01
I	BUCHA PLÁSTICA CASQUILLO BUSHING	01
Z	PARAFUSO CF 4,5X25 TORNILLO CF 4,5X25 SCREW CF 4,5X25	04
PX	PUXADOR TIRADOR HANDLE	04
PE	PÉ PIE FOOT	04
V	COLA PEGAMENTO GLUE	01

### Lista de ferragens Hardware list Lista de materiales

FERRAMENTAS NECESSÁRIAS:  
HERRAMIENTAS NECESÁRIAS:  
NECESSARY TOOLS:

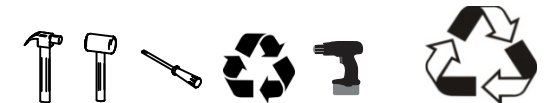

**"IMPORTANTE LER COM ATENÇÃO  
E GUARDAR PARA EVENTUAIS  
CONSULTAS".**

**"IMPORTANTE LEER CON ATENCIÓN Y GUARDAR PARA  
EVENTUALES CONSULTAS".**

**"IMPORTANT TO READ CAREFULLY AND SAVE FOR ANY  
QUERIES".**

FERRAMENTAS  
NECESSÁRIAS:



H	PERFIL PERFIL PROFILE	02
---	-----------------------------	----

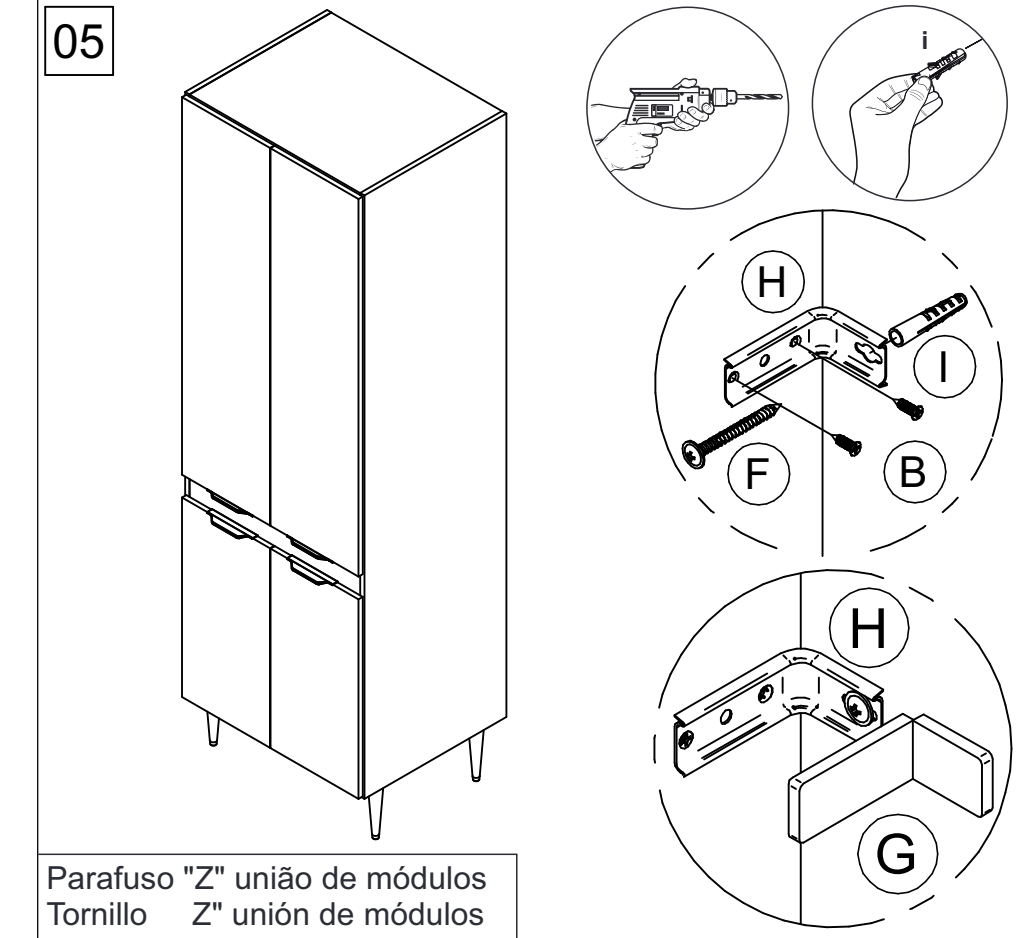
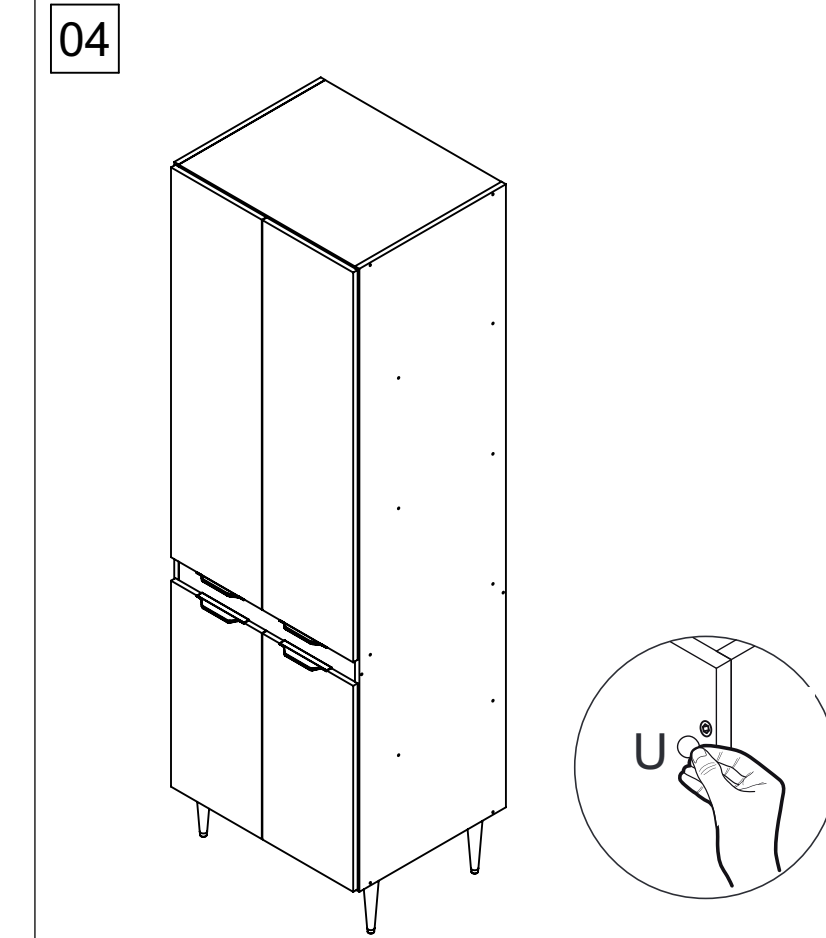
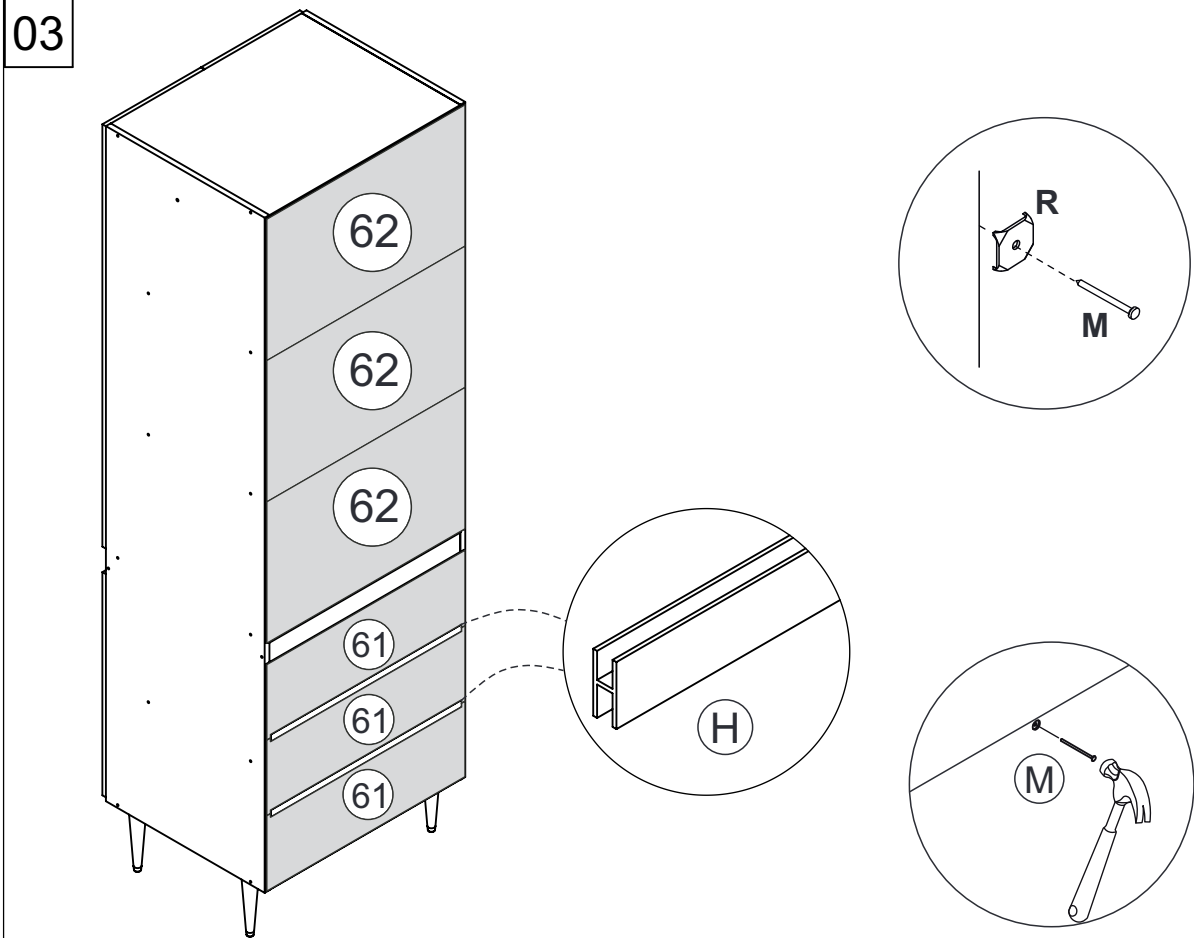
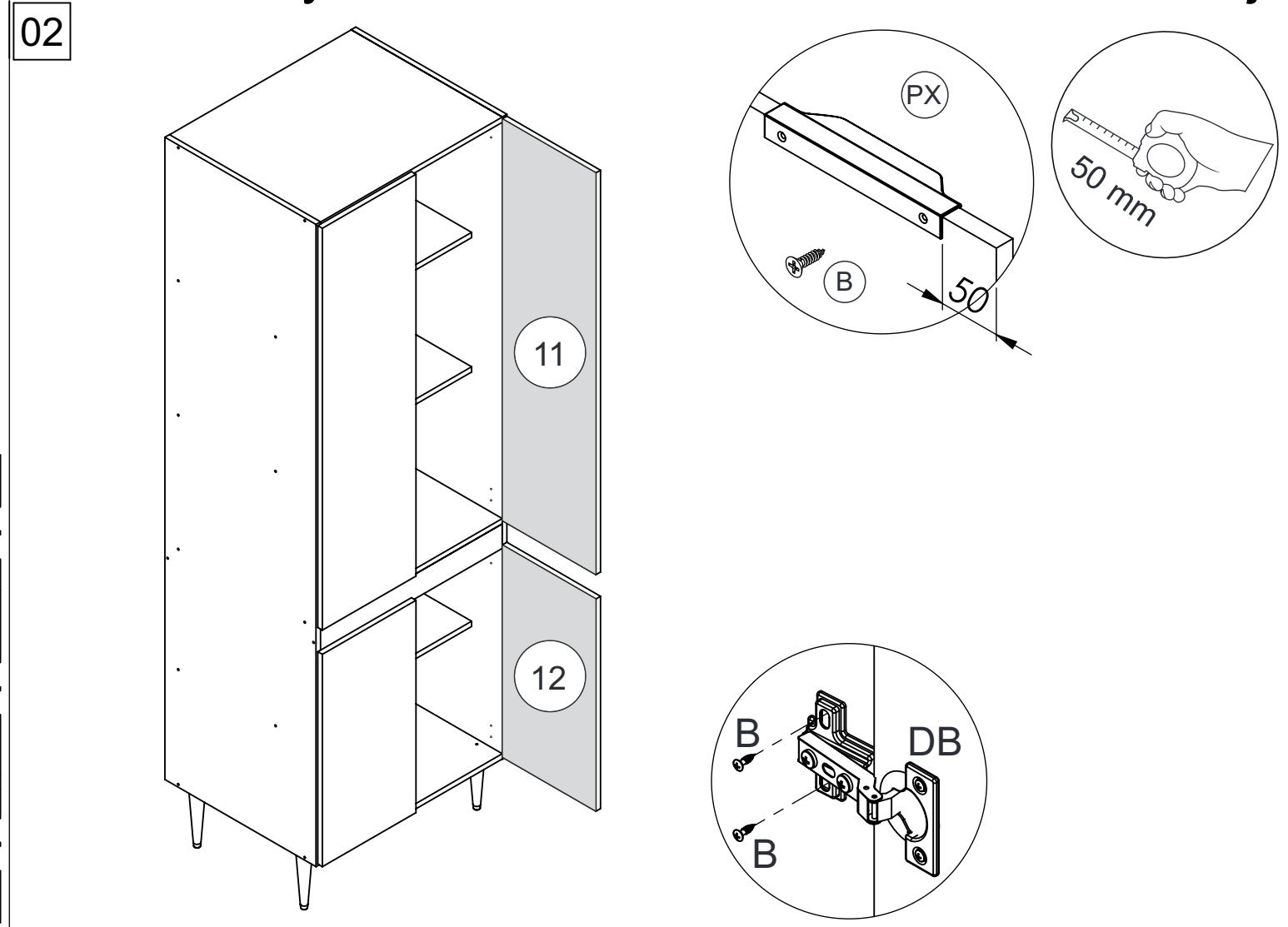
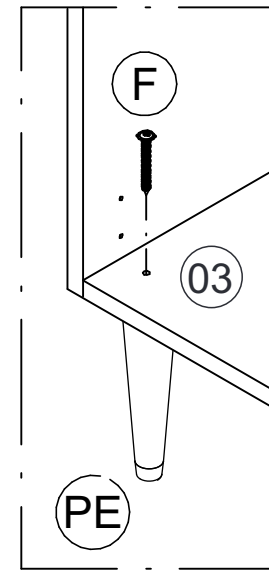
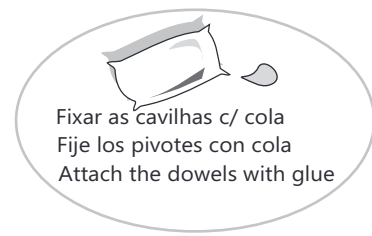
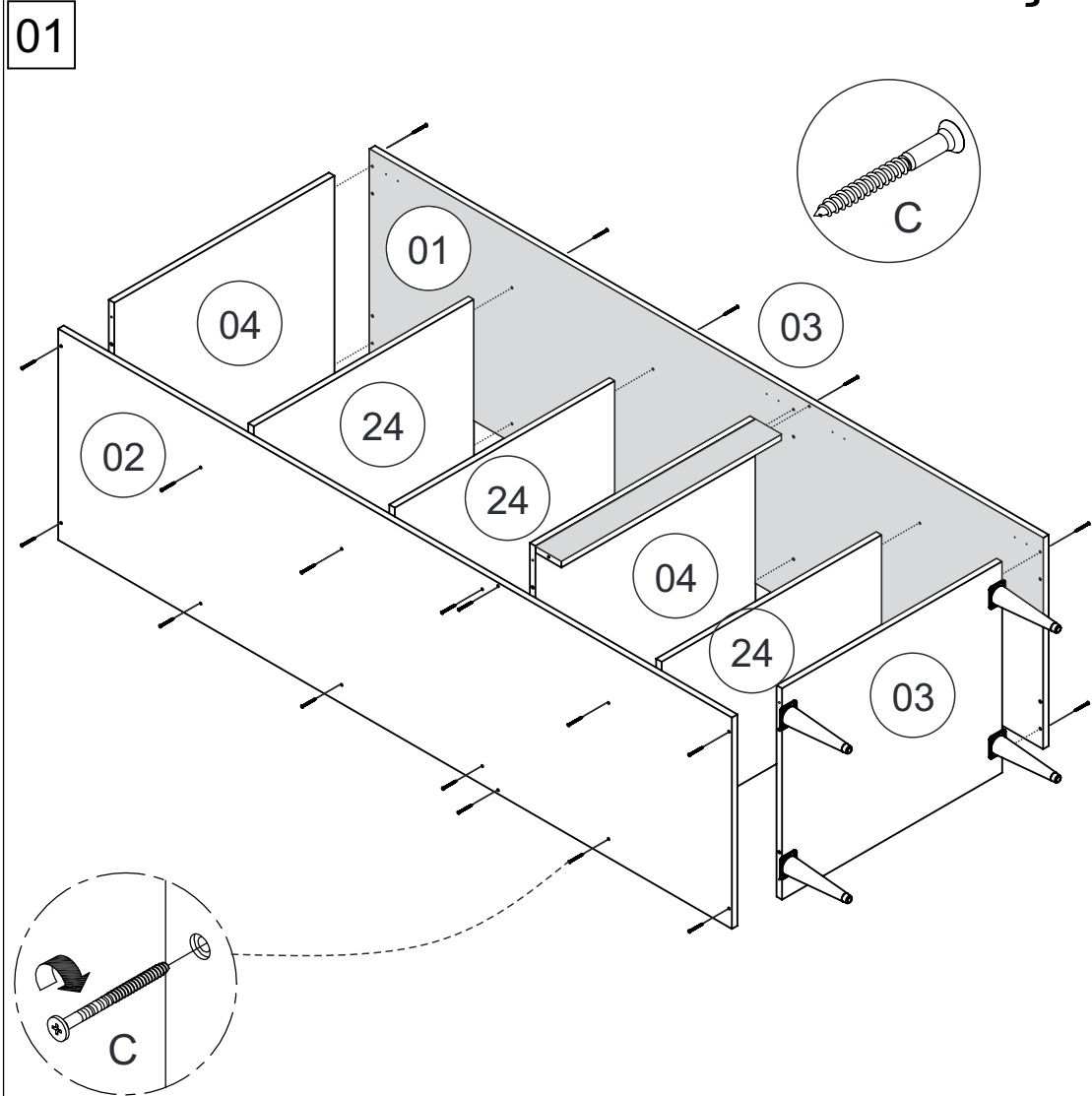

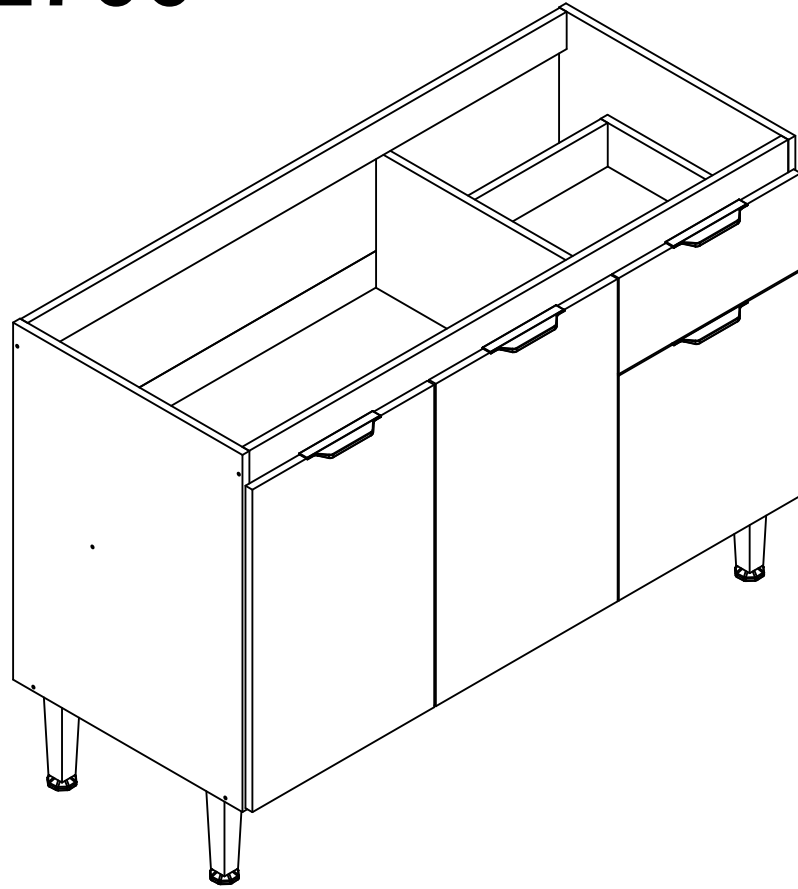

### Lista de ferragens

### Lista de materiales Hardware list

<b>A</b>		CAVILHA Ø6X30 CLAVIJA Ø6X30 WOOD DOWEL Ø6X30	<b>20</b>
<b>B</b>		PARAFUSO CC 3,5X14 TORNILLO CC 3,5X14 SCREW CC 3,5X14	<b>50</b>
<b>C</b>		PARAFUSO CC 3,5X40 TORNILLO CC 3,5X40 SCREW CC 3,5X40	<b>14</b>
<b>DB</b>		DOBRADIÇA 26 CALÇO 1 BISAGRA HINGE	<b>06</b>
<b>F</b>		PARAFUSO CF 4,5X50 TORNILLO CF 4,5X50 SCREW CF 4,5X50	<b>06</b>
<b>M</b>		PREGO 10X10 CLAVO 10X10 NAIL	<b>50</b>
<b>L</b>		CANTONERA ESQUINERO CORNER	<b>04</b>
<b>U</b>		ADESIVO TAPA FURO ADHESIVO STICKER	<b>10</b>
<b>V</b>		COLA PEGAMENTO GLUE	<b>01</b>
<b>PE</b>		PÉ PIE FOOT	<b>05</b>
<b>PX</b>		PUXADOR TIRADOR HANDLE	<b>04</b>
<b>G</b>		SUPORTE FIXAÇÃO SOPORTE DE FIJACIÓN FIXING SUPPORT	<b>01</b>
<b>H</b>		PROTEÇÃO SUP CANTONEIRA PROTECCIÓN ANGLE BRACKET	<b>01</b>
<b>I</b>		BUCHA PLÁSTICA CASQUILLO BUSHING	<b>01</b>
<b>Z</b>		PARAFUSO CC 3,5X30 TORNILLO CC 3,5X30 SCREW CC 3,5X30	<b>03</b>
<b>CR</b>		CORREDIÇA 350 CORREDERA SLIDE	<b>01</b>
<b>Y</b>		PERFIL 1170 PERFIL DE LA UNIÓN UNION PROFILE	<b>02</b>

### Lista de peças / Parts lists / Lista de piezas

REF	DESC	COMP	LARG	ESP	QTD.
VE2700-01	LATERAL DIREITA/LADO DERECHO/RIGHT SIDE	670	497	15	1
VE2700-02	LATERAL ESQUERDA/LADO IZQUIERDO/LEFT SIDE	670	497	15	1
VE2700-03	BASE/BASE/BASE	1168	497	15	1
VE2700-04	PRATELEIRA/ESTANTE/SHELF	771	296	15	1
VE2700-05	DIVISAO/DIVISION/DIVISION	584	497	15	1
VE2700-06	TRAVESSA FRONTAL/TRAVESAN~I/LONG PLATE	1168	70	15	1
VE2700-11	PORTA/PUERTA/DOOR	394	422	15	1
VE2700-12	PORTA/PUERTA/DOOR	394	605	15	2
VE2700-15	LATERAL GAVETA/CAJÓN LATERAL/SIDE DRAWER	380	82	15	2
VE2700-18	COSTA GAVETA/FONDO DEL CAJÓN/FONDO/BACK	326	82	15	1
VE2700-20	FRENTE GAVETA/FRENTE DE CAJÓN/DRAWER FRONT	394	180	15	1
VE2700-26	TRAVESSA TRASERA/TRAVESAN~I/LONG PLATE	1168	70	15	1
VE2700-60	COSTA/FONDO/BACK	383	353	3	1
VE2700-61	COSTA/FONDO/BACK	1190	204	3	3

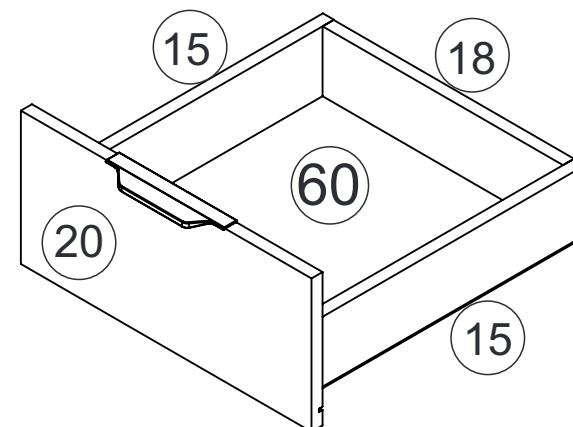
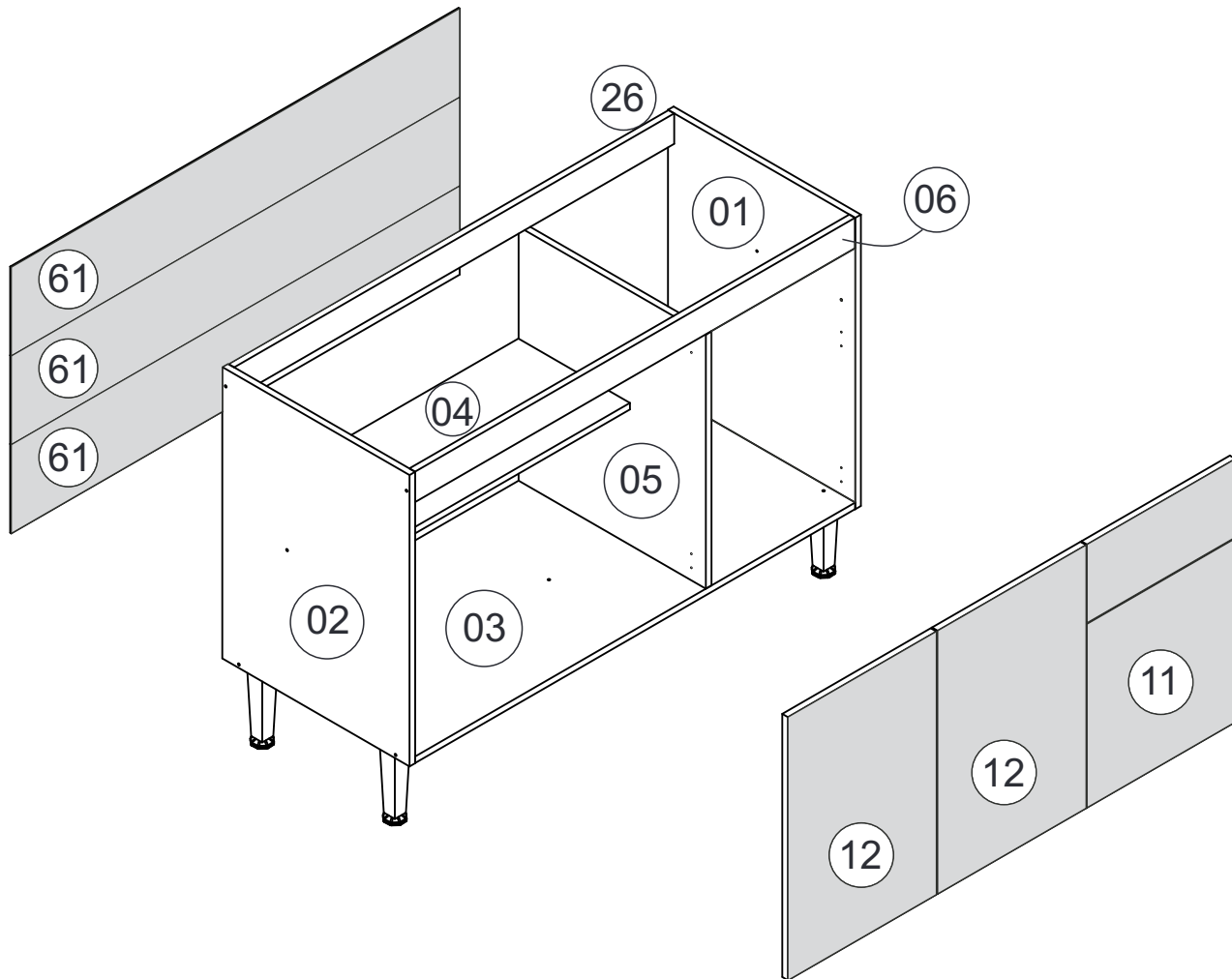

FERRAMENTAS NECESSÁRIAS:  
HERRAMIENTAS NECESARIAS:  
NECESSARY TOOLS:



**"IMPORTANTE LER COM ATENÇÃO  
E GUARDAR PARA EVENTUAIS  
CONSULTAS".**

**"IMPORTANTE LEER CON ATENCIÓN Y GUARDAR PARA  
EVENTUALES CONSULTAS".**

**"IMPORTANT TO READ CAREFULLY AND SAVE FOR ANY  
QUERIES".**

**FERRAMENTAS  
NECESSÁRIAS:**

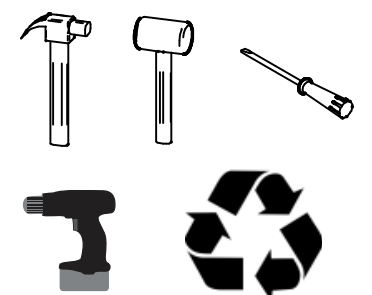

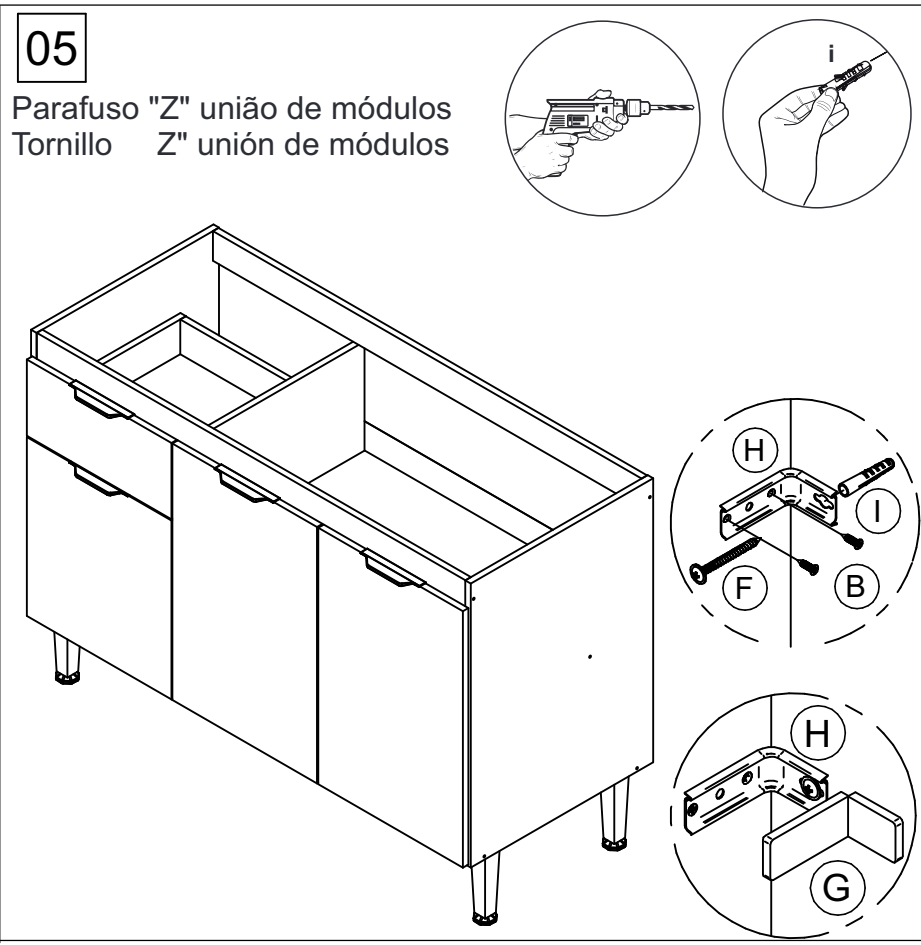
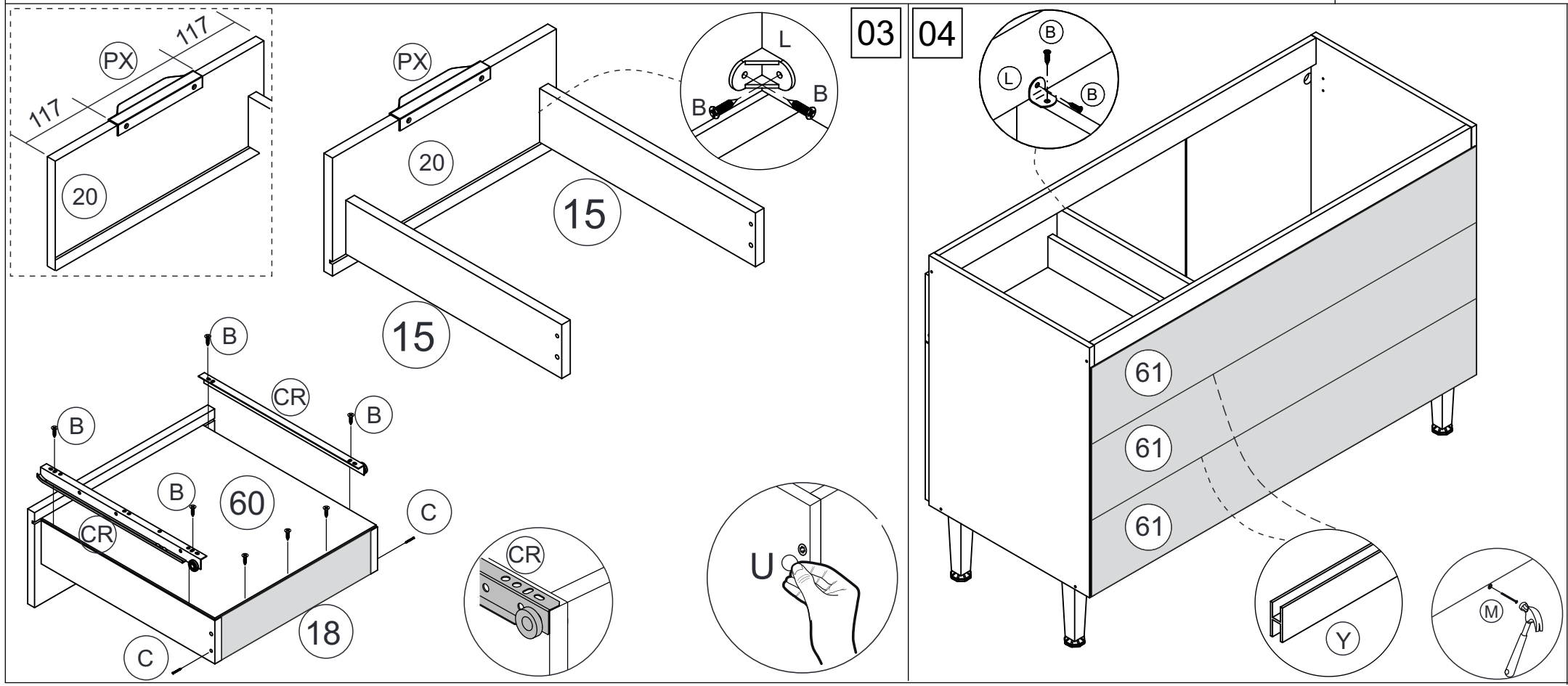
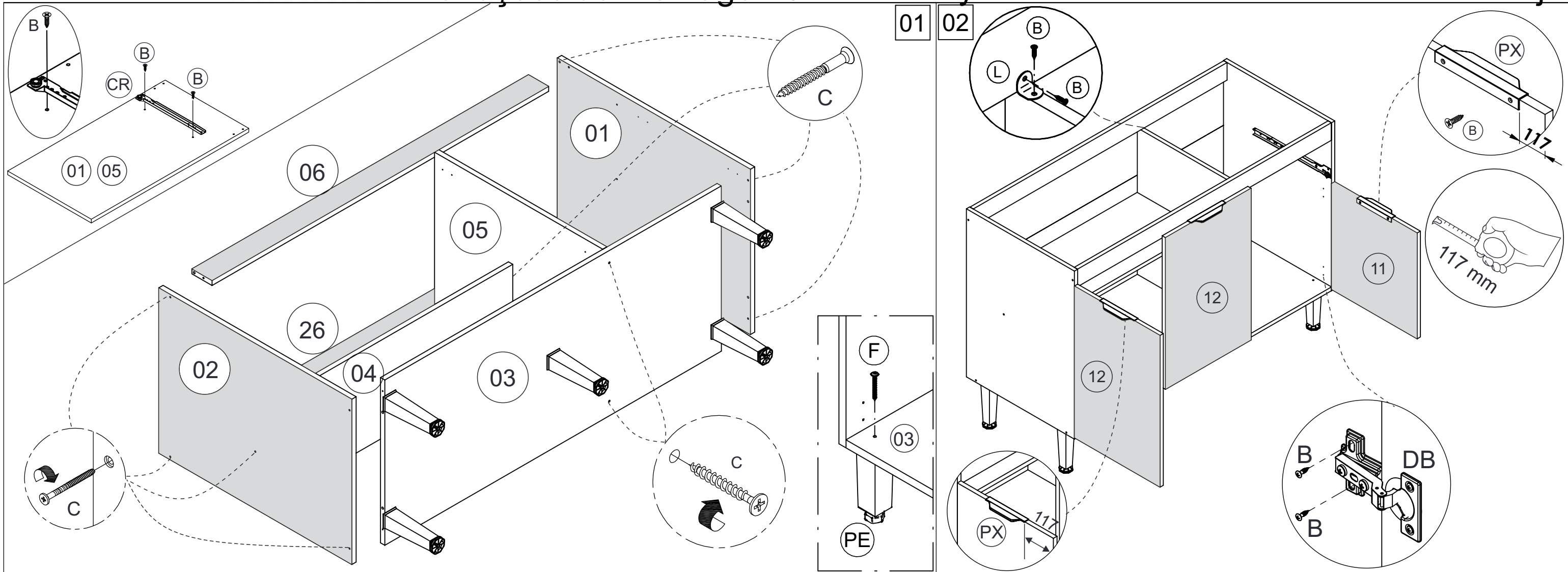

# VE 2800 Aereo Basculante 120

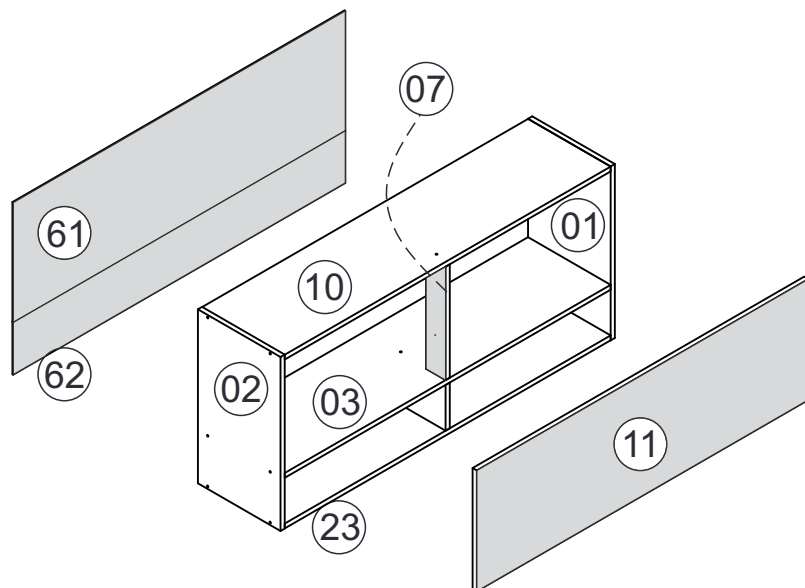
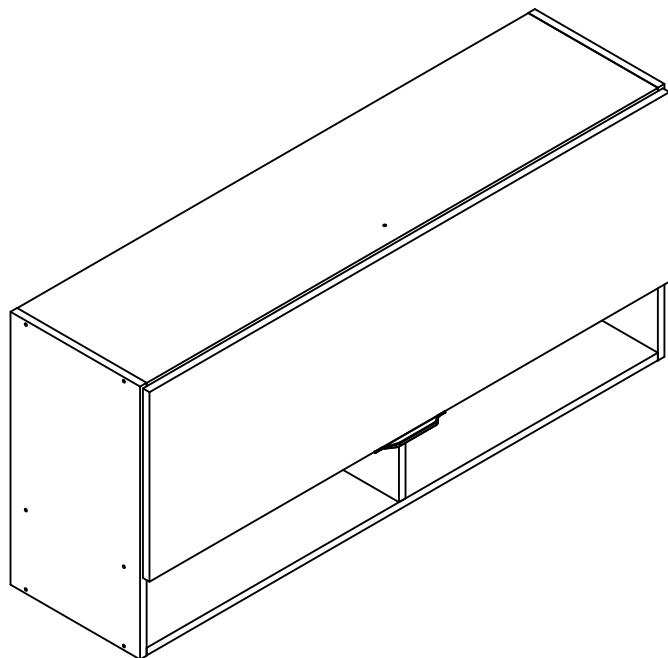

A		CAVILHA Ø6X30 CLAVIJA Ø6X30 WOOD DOWEL Ø6X30	18
B		PARAFUSO CC 4X14 TORNILLO CC 4X14 SCREW CC 4X14	18
C		PARAFUSO CC 4X40 TORNILLO CC 4X40 SCREW CC 4X40	16
DB		DOBRADIÇA 26 ALTA BISAGRA HINGE	03
F		PARAFUSO CF 4,5X50 TORNILLO CF 4,5X50 SCREW CF 4,5X50	02
M		PREGO 10X10 CLAVO 10X10 NAIL	50
U		ADESIVO TAPA FURO ADHESIVO STICKER	06
Z		FIXADOR COSTAS FIJADOR PRARA FONDO BACK SUPPORT	08
Z		PARAFUSO CC 4X30 TORNILLO CC 4X30 SCREW CC 4X30	03
G		SUPORTE FIXAÇÃO SOPORTE DE FIJACIÓN FIXING SUPPORT	02
H		PROTEÇÃO SUP CANTONEIRA PROTECCIÓN ANGLE BRACKET	02
I		BUCHA PLÁSTICA CASQUILLO BUSHING	02
PX		PUXADOR TIRADOR HANDLE	01
P		PISTAO PISTON PISTON	01
V		COLA PEGAMENTO GLUE	01

Assembly Instructions / Instrucciones de Montaje  
Instruções de Montagem /

01

FERRAMENTAS NECESSÁRIAS:  
HERRAMIENTAS NECESARIAS:  
NECESSARY TOOLS:



**"IMPORTANTE LER COM ATENÇÃO  
E GUARDAR PARA EVENTUAIS  
CONSULTAS".**

**"IMPORTANTE LEER CON ATENCIÓN Y GUARDAR PARA  
EVENTUALES CONSULTAS".**  
**"IMPORTANT TO READ CAREFULLY AND SAVE FOR ANY  
QUERIES".**

Lista de peças / Parts lists / Lista de piezas

REF	DESC	COMP	LARG	ESP	QTD.
VE2800-01	LATERAL DIREITA/LADO DERECHO/RIGHT SIDE	540	296	15	1
VE2800-02	LATERAL ESQUERDA/LADO IZQUIERDO/LEFT SIDE	540	296	15	1
VE2800-03	BASE/BASE/BASE	1168	296	15	1
VE2800-05	DIVISAO/DIVISIÓN/DIVISION	142	296	15	1
VE2800-07	PILASTRA/PILAR/PILLAR	352	70	15	1
VE2800-10	TAMPO/TAPA/TOP	1168	296	15	1
VE2800-11	PORTA/PUERTA/DOOR	1188	375	15	1
VE2800-23	BASE/BASE/BASE	1168	296	15	1
VE2800-61	COSTA/FONDO/BACK	1190	372	3	1
VE2800-62	COSTA/FONDO/BACK	1190	162	3	1

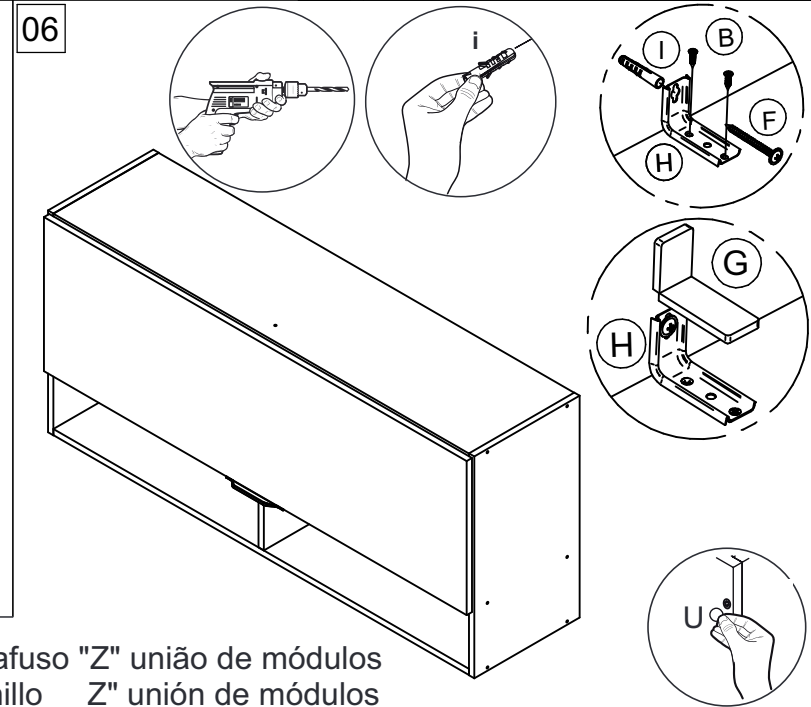
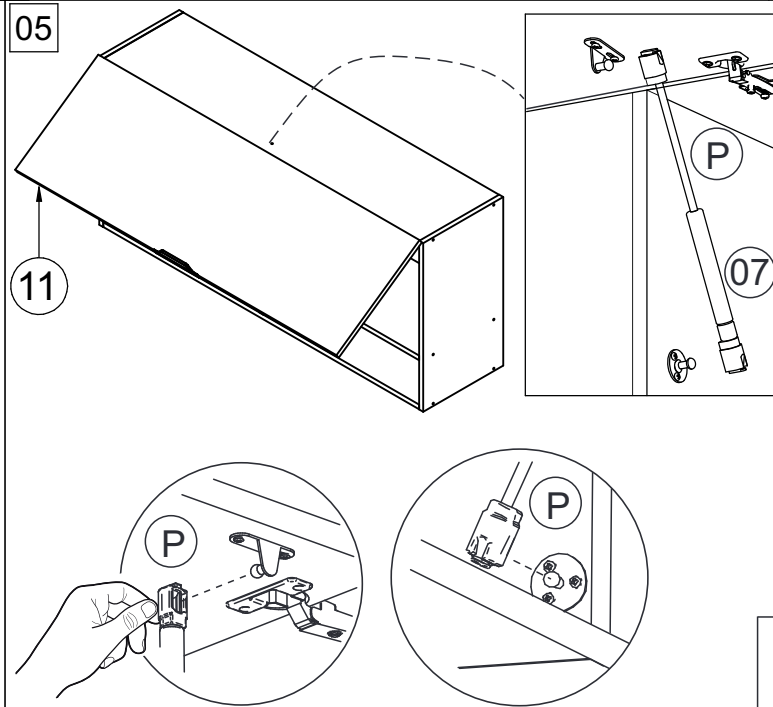
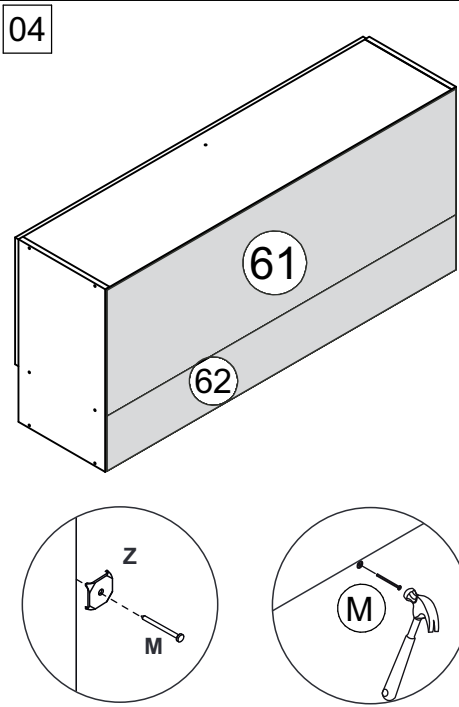
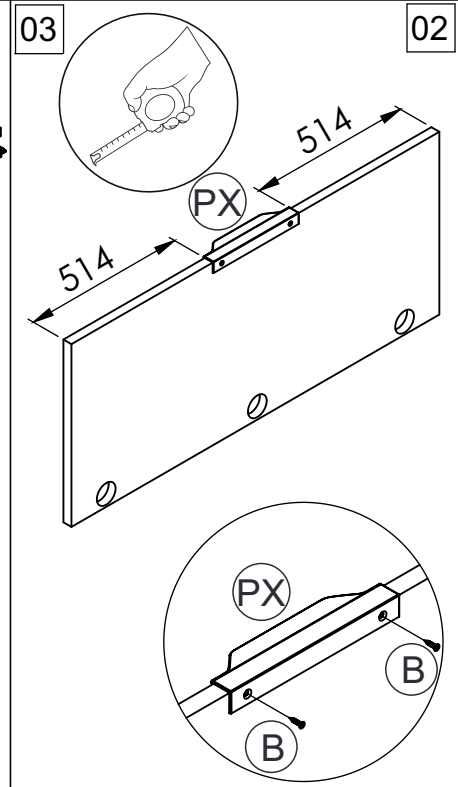
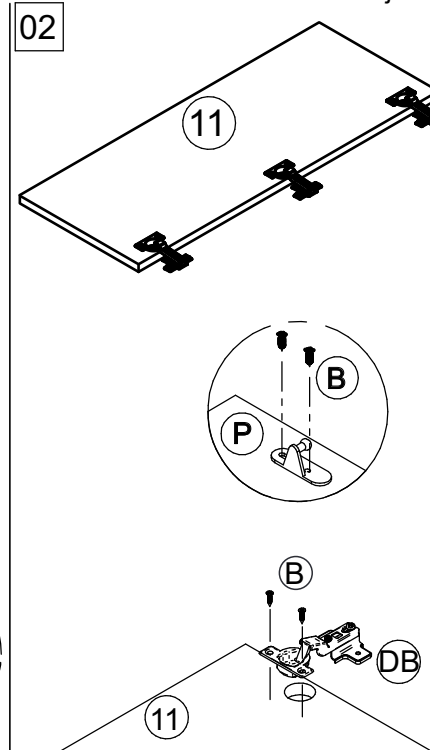
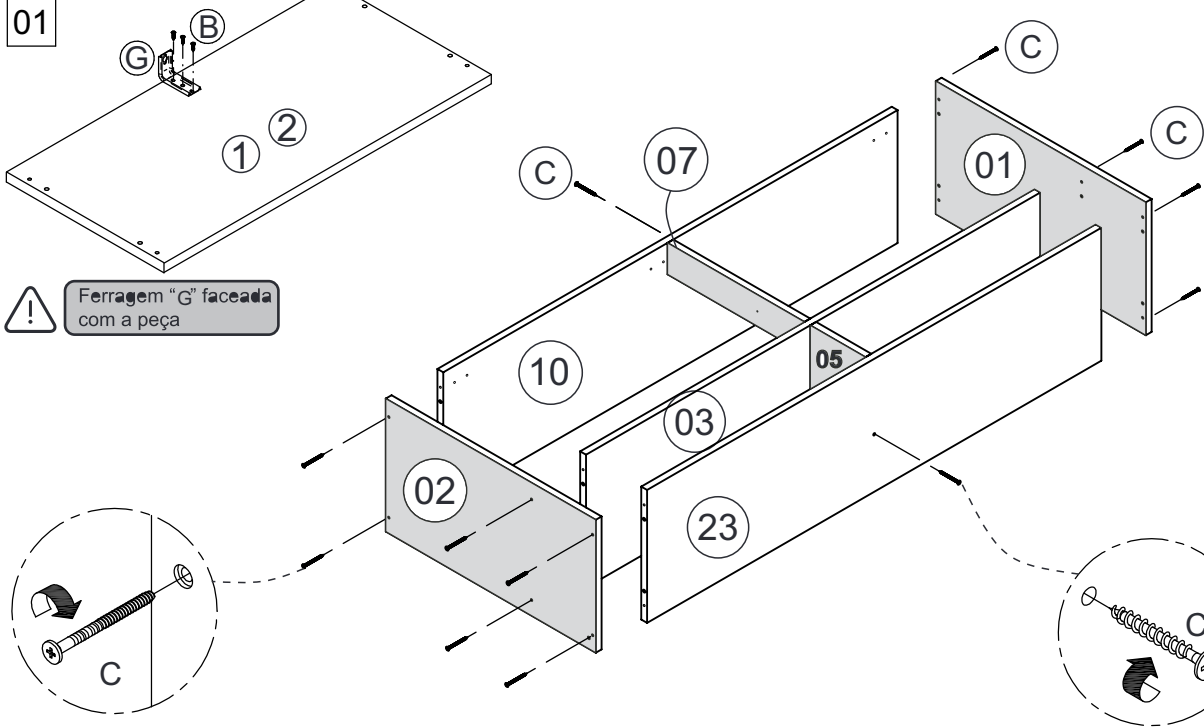

# VE 2900 Instruções de Montagem / Assembly Instructions / Instrucciones de Montaje

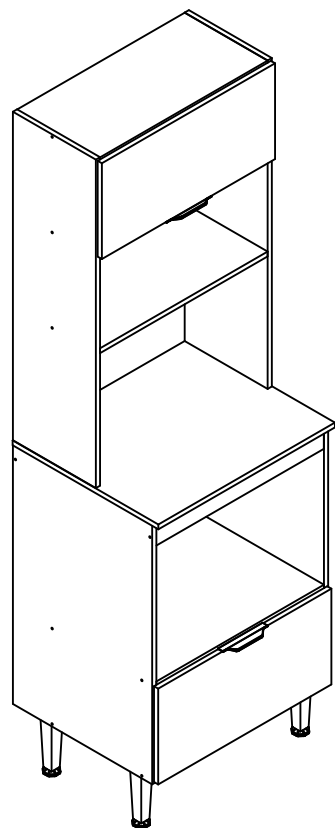

FERRAMENTAS NECESSÁRIAS:  
HERRAMIENTAS NECESARIAS:  
NECESSARY TOOLS:



**"IMPORTANTE LER COM ATENÇÃO  
E GUARDAR PARA EVENTUAIS  
CONSULTAS".**

"IMPORTANTE LEER CON ATENCIÓN Y GUARDAR PARA  
EVENTUALES CONSULTAS".  
"IMPORTANT TO READ CAREFULLY AND SAVE FOR ANY  
QUERIES".

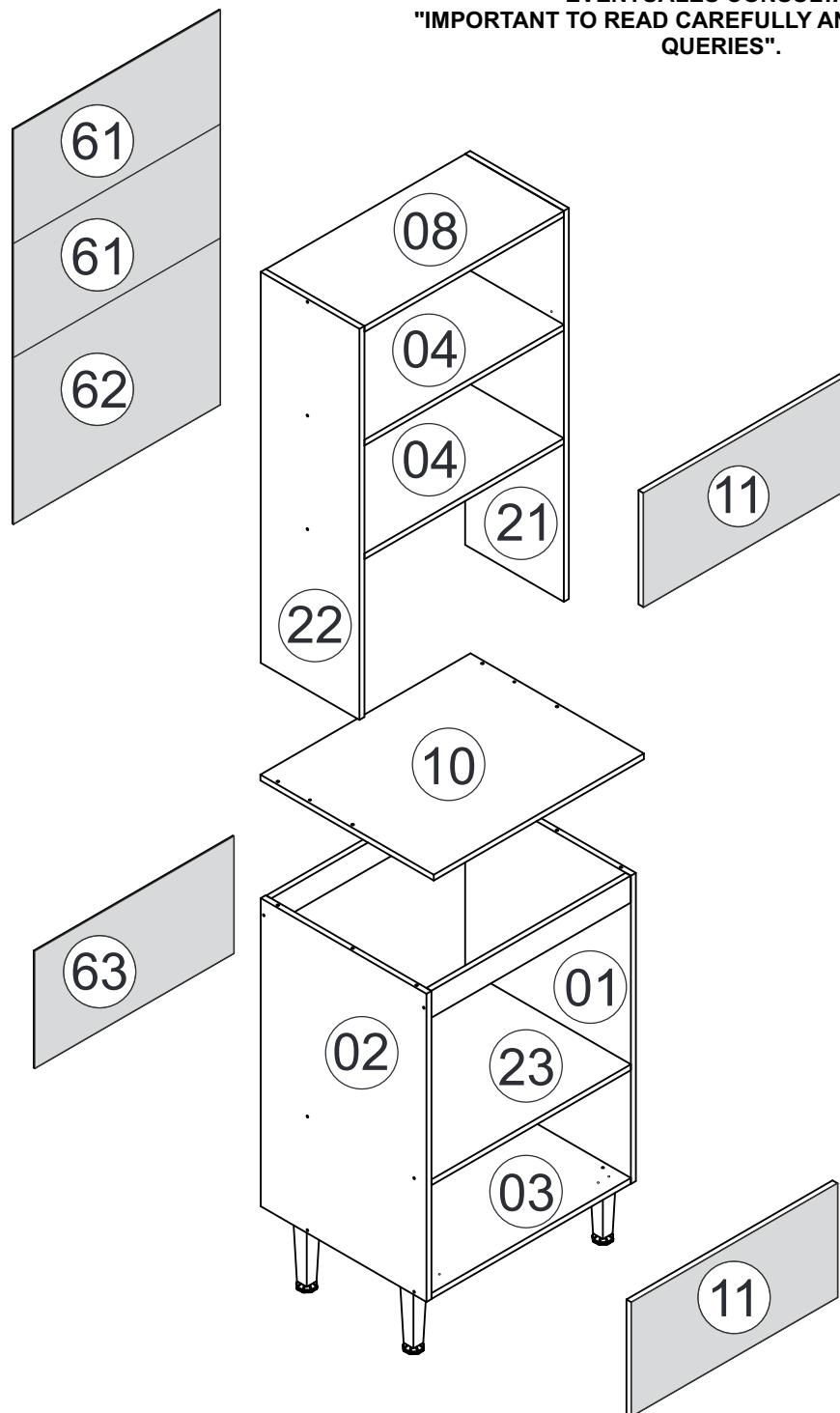

## Lista de peças / Parts lists / Lista de piezas

REF	DESC	COMP	LARG	ESP	QTD.
VE2900-01	LATERAL DIREITA/LADO DERECHO/RIGHT SIDE	800	497	15	1
VE2900-02	LATERAL ESQUERDA/LADO IZQUIERDO/LEFT SIDE	800	497	15	1
VE2900-03	BASE/BASE/BASE	445	598	15	1
VE2900-04	PRATELEIRA/ESTANTE/SHELF	296	598	15	2
VE2900-06	TRAVESSA FRONTAL/TRAVESAN~I/LONG PLATE	598	70	15	1
VE2900-08	CHAPEU/SOMBRERO/HAT	296	598	15	1
VE2900-10	TAMPO/TAMPO/TAMPO	630	520	15	1
VE2900-11	PORTA/PUERTA/DOOR	618	296	15	2
VE2900-21	LATERAL DIREITA/LADO DERECHO/RIGHT SIDE	1015	296	15	1
VE2900-22	LATERAL ESQUERDA/LADO IZQUIERDO/LEFT SIDE	1015	296	15	1
VE2900-23	BASE FORNO/HORNO BASE/BASE OVEN	445	598	15	1
VE2900-26	TRAVESSA TRASERA/TRAVESAN~I/LONG PLATE	598	70	15	1
VE2900-61	COSTA/FONDO/BACK	620	296	3	2
VE2900-62	COSTA/FONDO/BACK	620	432	3	1
VE2900-63	COSTA/FONDO/BACK	597	304	3	1

A		CAVILHA Ø6X30 CLAVIJA Ø6X30 WOOD DOWEL Ø6X30	34
B		PARAFUSO CC 3,5X14 TORNILLO CC 3,5X14 SCREW CC 3,5X14	34
C		PARAFUSO CC 3,5X40 TORNILLO CC 3,5X40 SCREW CC 3,5X40	20
DB		DOBRADIÇA 26 CALÇO 1 BISAGRA HINGE	04
R		FIXADOR COSTAS FIJADOR PRARA FONDO BACK SUPPORT	10
F		PARAFUSO CF 4,5X50 TORNILLO CF 4,5X50 SCREW CF 4,5X50	05
M		PREGO 10X10 CLAVO 10X10 NAIL	65
L		CANTONERA ESQUINERO CORNER	04
U		ADESIVO TAPA FURO ADHESIVO STICKER	09
V		COLA PEGAMENTO GLUE	01
PE		PÉ PIE FOOT	04
PX		PUXADOR TIRADOR HANDLE	02
G		SUPORTE FIXAÇÃO SOPORTE DE FIJACIÓN FIXING SUPPORT	01
H		PROTEÇÃO SUP CANTONEIRA PROTECCIÓN ANGLE BRACKET	01
I		BUCHA PLÁSTICA CASQUILLO BUSHING	01
Z		PARAFUSO CC 3,5X30 TORNILLO CC 3,5X30 SCREW CC 3,5X30	03
P		PISTAO PISTON PISTON	01
Y		ARTICULADOR ARTICULADOR ARTICULADOR	01

Lista de ferragens  
Hardware list  
Lista de materiales

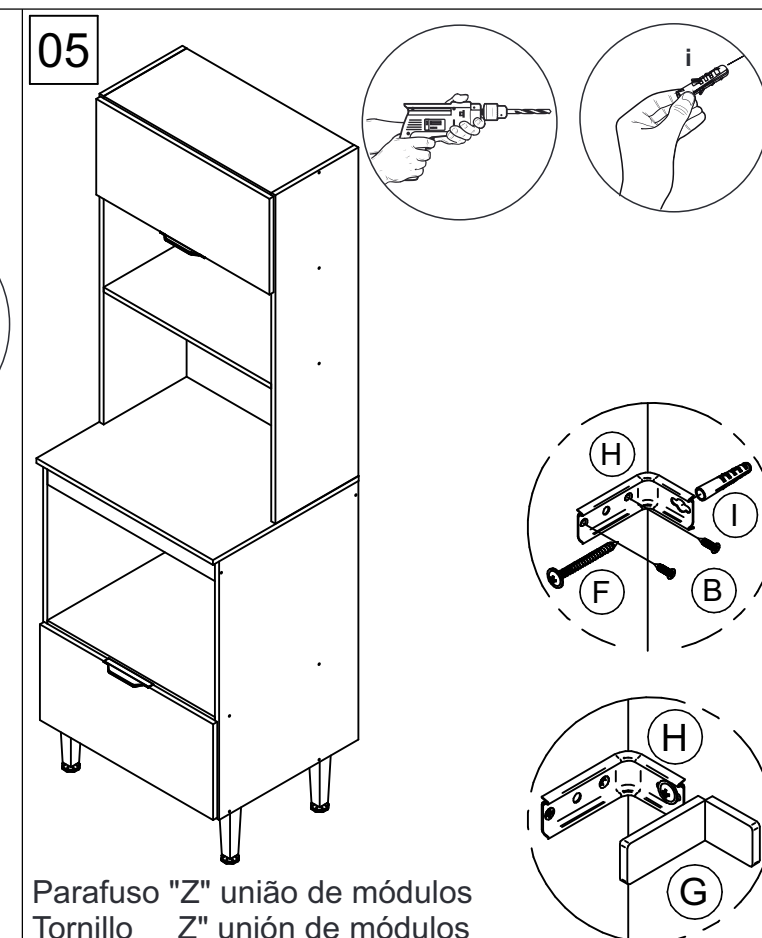
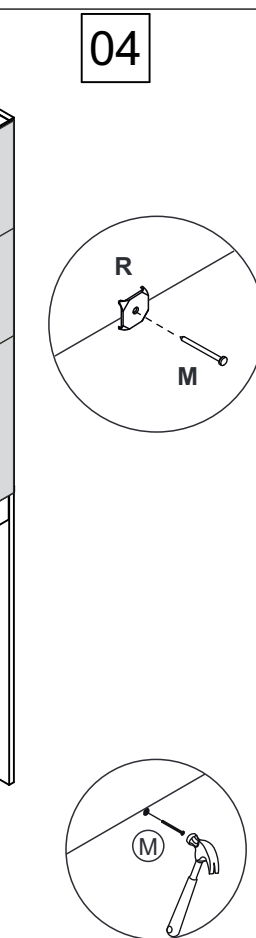
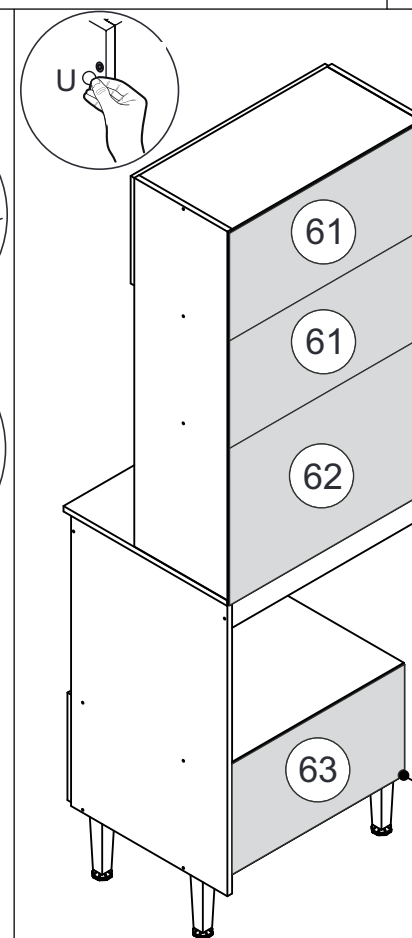
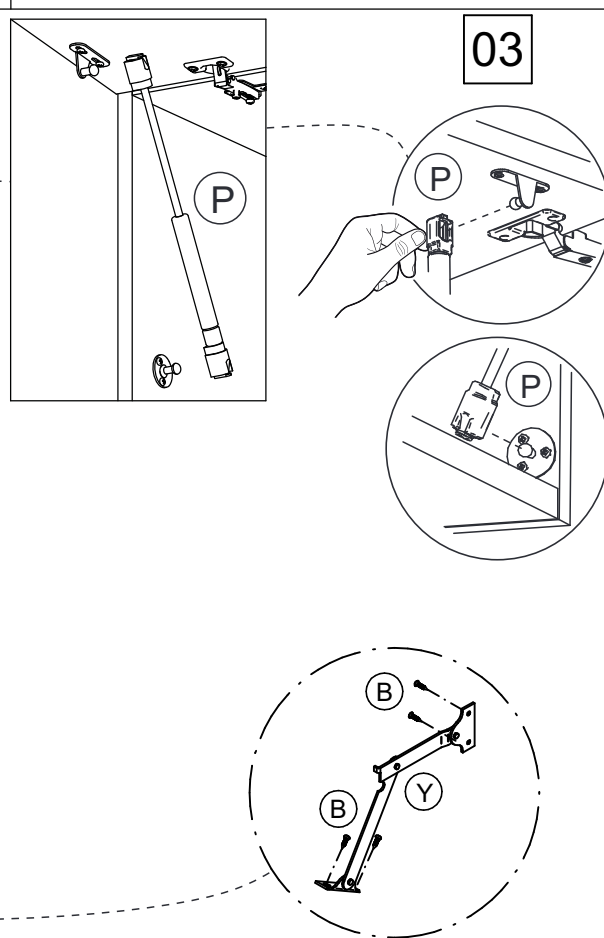
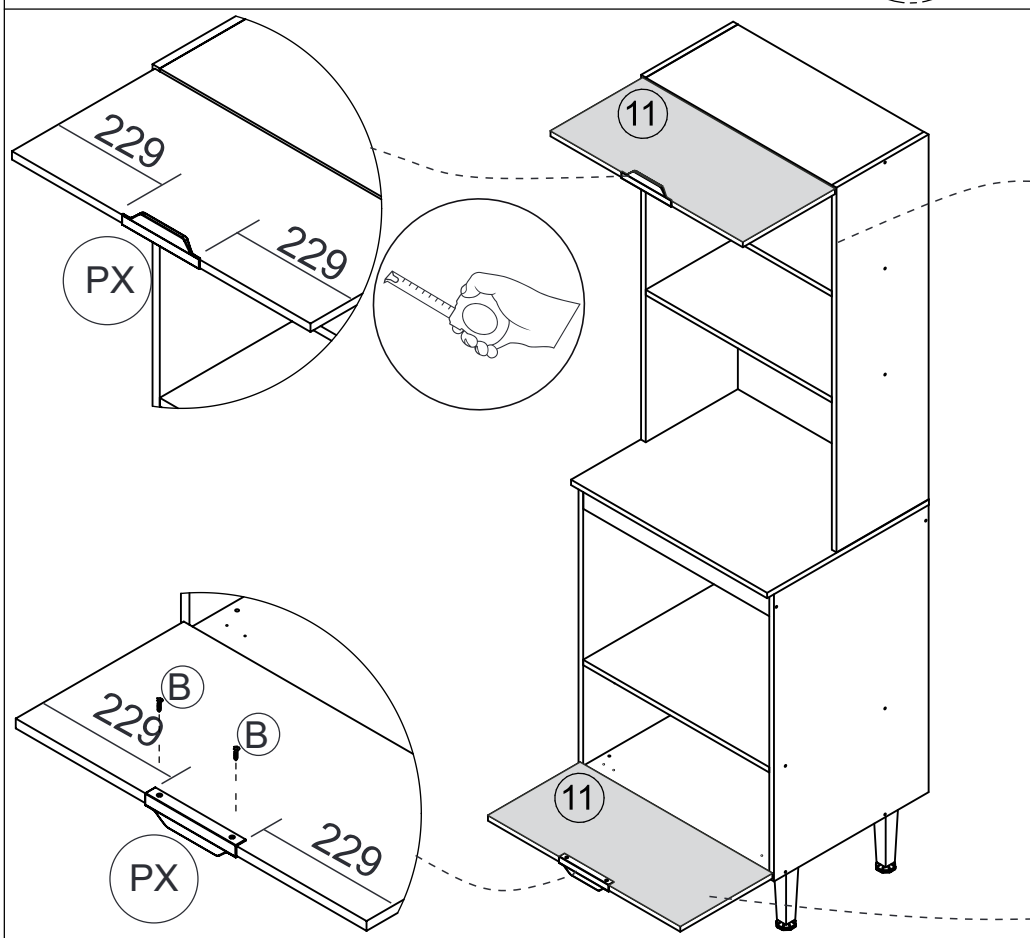
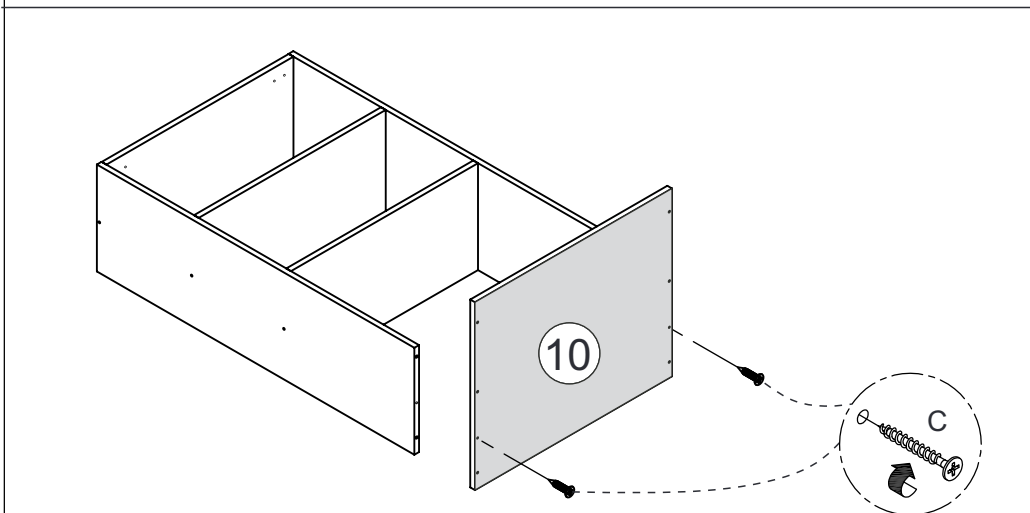
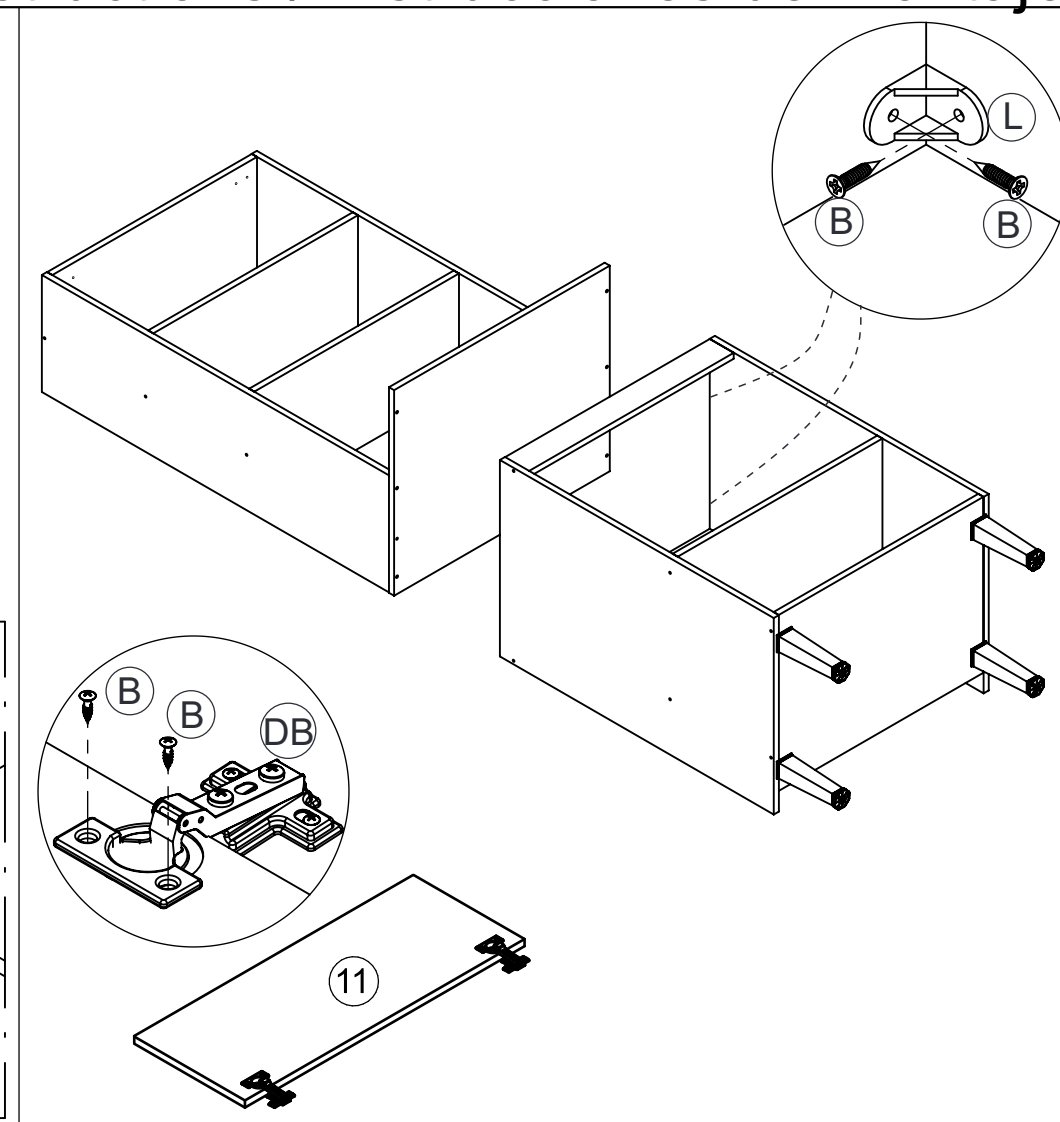
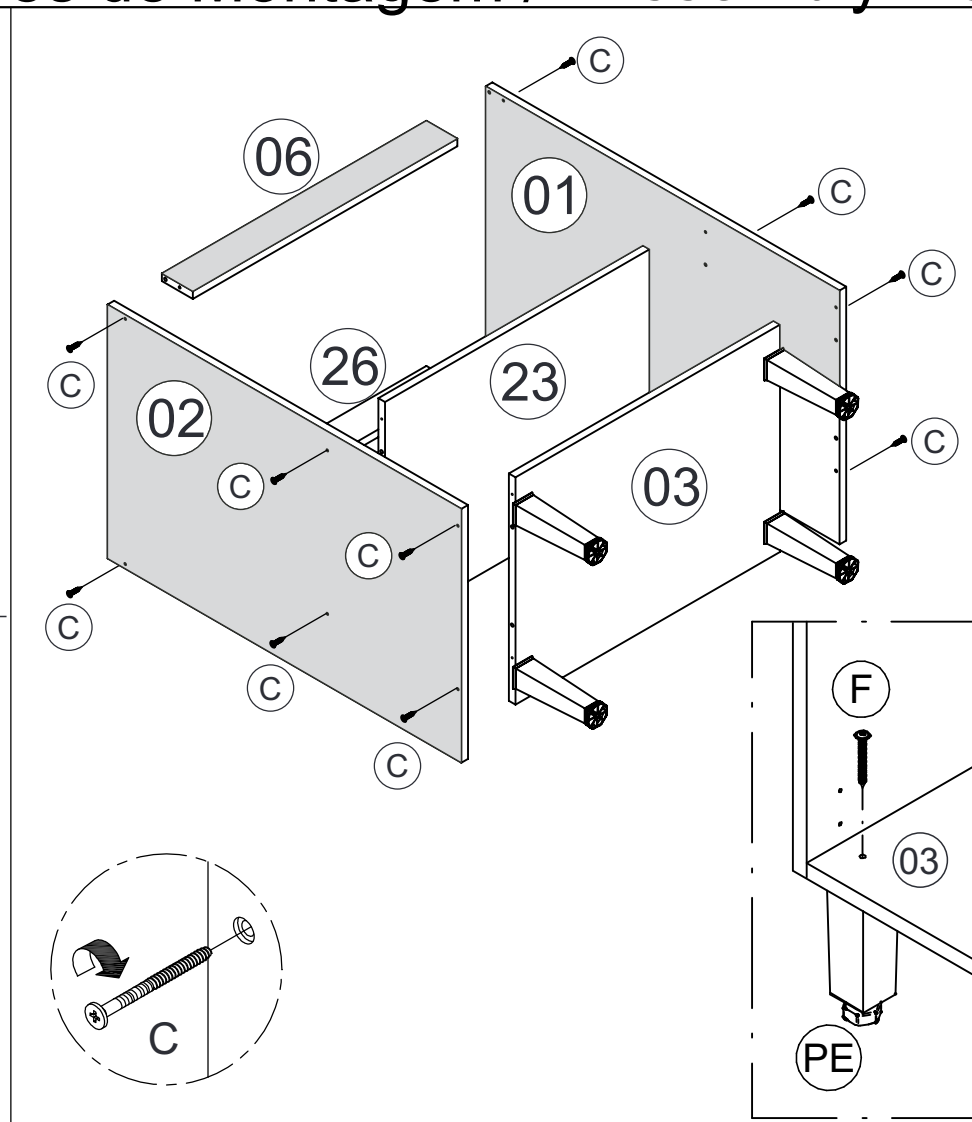
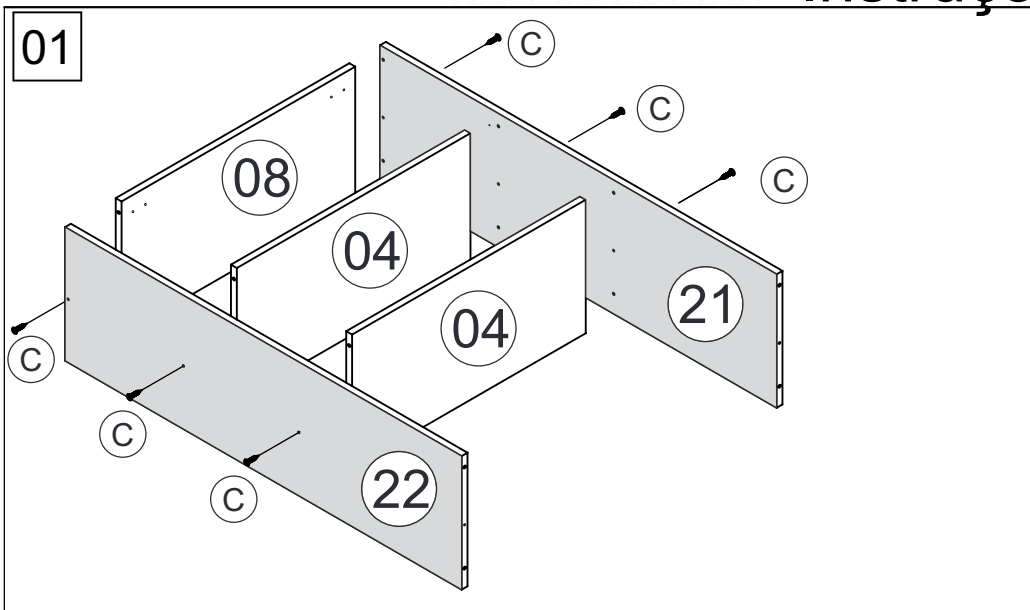

Parafuso "Z" união de módulos  
Tornillo "Z" unión de módulos