

JA9115 BALCÃO CANTO

Instruções de montagem Assembly Instructions / Instrucciones de Montaje

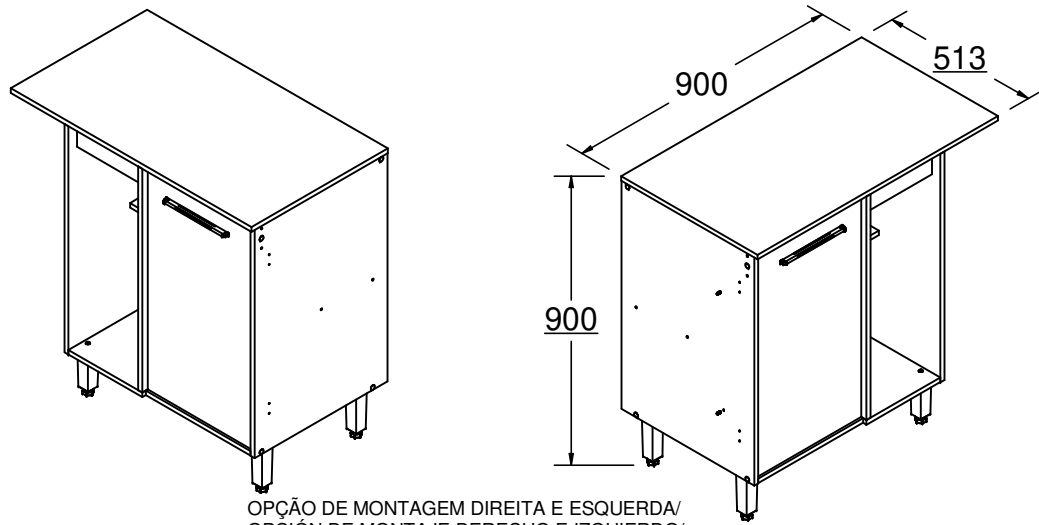

OPÇÃO DE MONTAGEM DIREITA E ESQUERDA/
OPCIÓN DE MONTAJE DERECHO E IZQUIERDO/
RIGHT AND LEFT ASSEMBLY OPTION/

REV.: 00
DATA: 27/08/2023

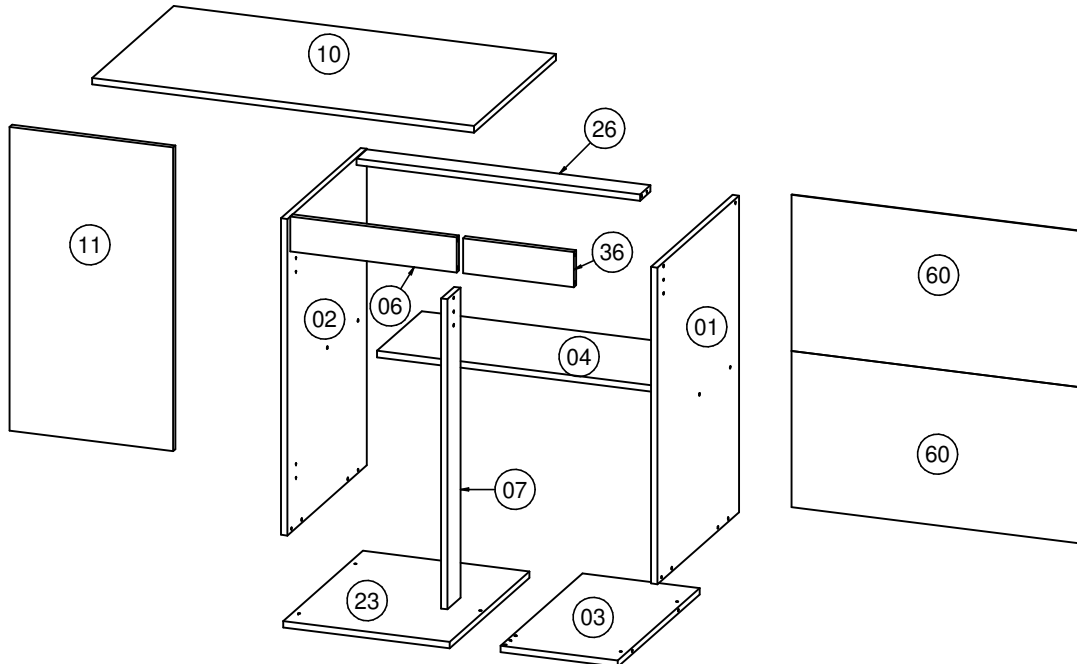

LISTA DE PEÇAS / LISTA DE PIEZAS / PARTS LIST			
COD	DESCRIÇÃO / DESCRIPCIÓN / DESCRIPTION	DIM / DIM / DIM	QTD
01	LATERAL DIREITA/ LATERAL DERECHO/ RIGHT SIDE	740 x 510 x 15	1
02	LATERAL ESQUERDA/ LATERAL IZQUIERDA/ LEFT SIDE	740 x 497 x 15	1
03	BASE MAIOR/ BASE/ BASE	276 x 510 x 15	1
04	PRATELEIRA/ ESTANTE/ SHELF	668 x 280 x 15	1
06	TRAVESSA/ TRAVESAÑO/ CROSSPIECE	392 x 82 x 15	1
07	PILASTRA/ TRAVESAÑO/ CROSSPIECE	725 x 82 x 15	1
10	TAMPO/ TAPA/ TOP	900 x 510 x 15	1
11	PORTA/ PUERTA/ DOOR	710 x 385 x 15	1
23	BASE MENOR/ BASE/ BASE	392 x 497 x 15	1
26	TRAVESSA TRASEIRA/ TRAVESAÑO/ CROSSPIECE	668 x 65 x 15	1
36	TRAVESSA/ TRAVESAÑO/ CROSSPIECE	261 x 82 x 15	1
60	COSTA/ FONDO/ BACK	690 x 365 x 3	2

LISTA DE FERRAGENS / LISTA DE ACCESORIOS / HARDWARE LIST			
COD	DESCRIÇÃO / DESCRIPCIÓN / DESCRIPTION		QTD
A	CAVILHA Ø6x30 CLAVIJA Ø6x30 WOOD DOWEL Ø6x30		12
B	PARAFUSO CC 3,5x14 REBAIXE TORNILLO CC 3,5x14 SCREW CC 3,5x14		29
C	PARAFUSO CC 3,5x40 TORNILLO CC 3,5x40 SCREW CC 3,5x40		10
D	CAVILHA Ø6x50 CLAVIJA Ø6x50 WOOD DOWEL Ø6x50		2
DB	DOBRADIÇA BISAGRA HINGE		2
E	PARAFUSO CF 3,5x30 TORNILLO CF 3,5x30 SCREW CF 3,5x30		2
F	PARAFUSO CF 4,5x50 TORNILLO CF 4,5x50 SCREW CF 4,5x50		6
G	SUPORTE FIXAÇÃO SOPORTE DE FIJACION FIXING SUPPORT		1
H	PROTEÇÃO SUP CANTONEIRA PROTECCIÓN ANGLE BRACKET		1
I	BUCHA PLÁSTICA CASQUILLO BUSHING		1
L	CANTONEIRA 18x18 ESQUINERO 18x18 CORNER 18x18		5
M	PREGO 10x10 CLAVO 10x10 NAIL		30
N	ADESIVO TAPA FURO ADHESIVO STICKER		8
PE	PÉ PIE FOOT		5
PX	PUXADOR TIRADOR HANDLE		1
S	SUPORTE PRATELEIRA SOPORTE DE ESTANTE SHELF SUPPORT		4
T	JUNÇÃO UNION JUNCTION		2
V	COLA PEGAMENTO GLUE		1
Y	PARAFUSO CC 3,5x30 TORNILLO CC 3,5x30 SCREW CC 3,5x30		2
Z	BATENTE SILICONE SILICONE STOP TAPÓN SILICONA		1

**"IMPORTANTE
LER COM
ATENÇÃO
E GUARDAR
PARA EVENTUAIS
CONSULTAS".**
"IMPORTANTE LEER CON
ATENCIÓN Y GUARDAR PARA
EVENTUALES CONSULTAS".
"IMPORTANT TO READ
CAREFULLY AND SAVE FOR
ANY QUERIES".

FERRAMENTAS NECESSÁRIAS:
HERRAMIENTAS NECESARIAS:
NECESSARY TOOLS:



