

FE 1230

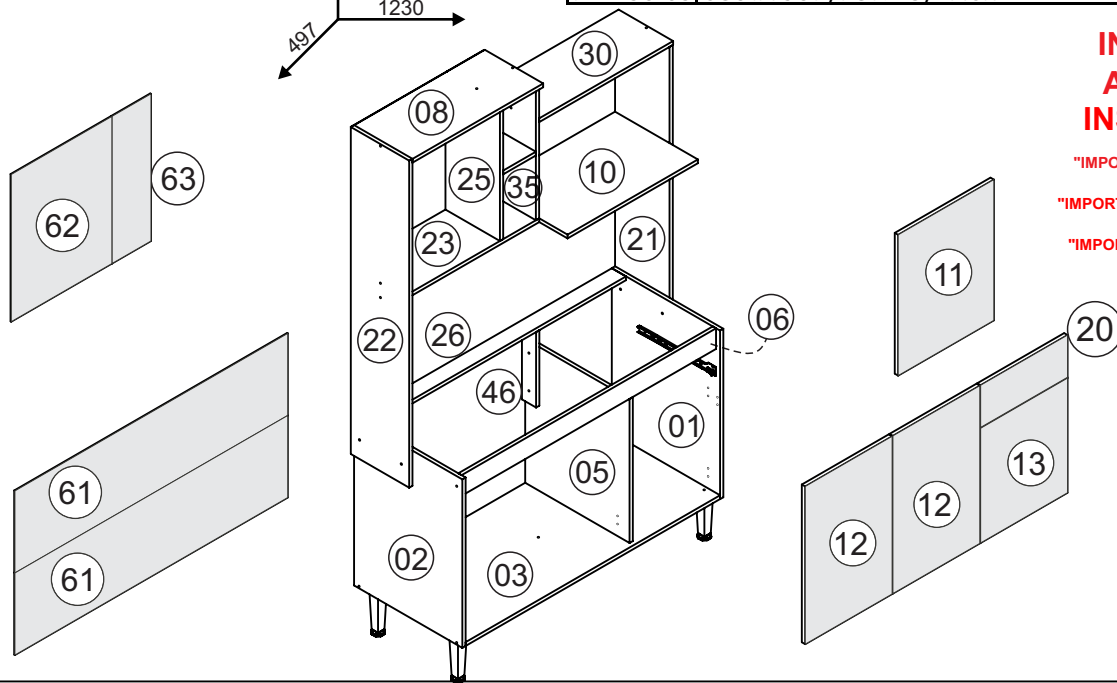
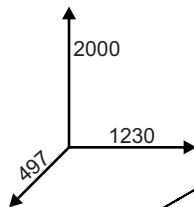
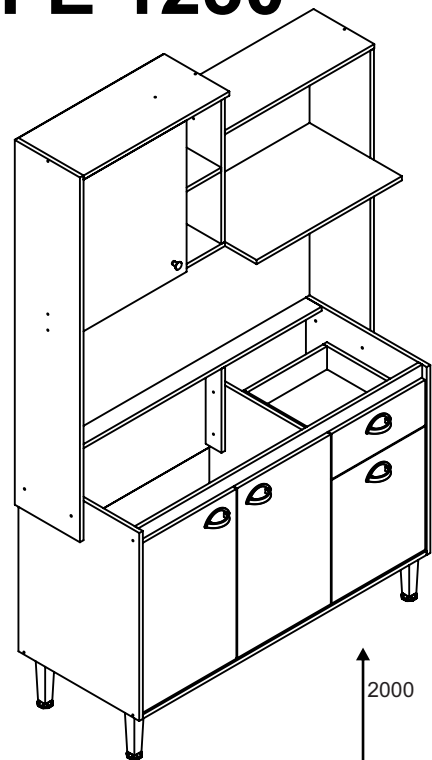

REF	DESC	COMP	LARG	ESP	QTD.
FE1230-01	LATERAL DIREITA/LADO DERECHO/RIGHT SIDE	670	497	15	1
FE1230-02	LATERAL ESQUERDA/LADO IZQUIERDO/LEFT SIDE	670	497	15	1
FE1230-03	BASE/BASE/BASE	497	1168	15	1
FE1230-04	PRATELERA/ESTANTE/SHELF	150	250	15	1
FE1230-05	DIVISAO/DIVISION/DIVISION	479	572	15	1
FE1230-06	TRAVESSA FRONTAL/PLATO/PLATTER	1168	82	15	1
FE1230-08	CHAPEU/SOMBRERO/HAT	268	600	15	1
FE1230-10	TAMPO MICRO/TAPA/TOP	380	598	15	1
FE1230-11	PORTA SUP/PUERTA/DOOR	540	424	15	1
FE1230-12	PORTA SUP/PUERTA/DOOR	385	605	15	2
FE1230-13	PORTA SUP/PUERTA/DOOR	385	440	15	1
FE1230-15	LATERAL GAVETA/LADO DEL CAJÓN/DRAWER SIDE	380	82	15	2
FE1230-18	COSTA GAVETA/COSTA CAJON/DRAWER COAST	327	82	15	1
FE1230-20	FRENTE GAVETA/FRENTE DE CAJÓN/DRAWER FRONT	385	162	15	1
FE1230-21	LATERAL DIREITA/LADO DERECHO/RIGHT SIDE	1150	250	15	1
FE1230-22	LATERAL ESQUERDA/LADO IZQUIERDO/LEFT SIDE	1300	268	15	1
FE1230-23	BASE/BASE/BASE	250	600	15	1
FE1230-25	DIVISAO/DIVISION/DIVISION	250	530	15	1
FE1230-26	TRAVESSA TRASERA/PLATO/PLATTER	1168	65	15	1
FE1230-30	TAMPO MICRO/TAPA/TOP	250	615	15	1
FE1230-35	DIVISAO/DIVISION/DIVISION	250	530	15	1
FE1230-36	TRAVESSA APOIO/PLATO/PLATTER	1198	100	15	1
FE1230-46	PILASTRA/PILLAR/PILAR	300	65	15	1
FE1230-60	FUNDO GAVETA/FONDO DE CAJÓN/DRAWER FUND	383	355	3	1
FE1230-61	COSTA/FONDO/BACK	1190	331	3	2
FE1230-62	COSTA SUP/FONDO/BACK	439	556	3	1
FE1230-63	COSTA SUP/FONDO/BACK	170	556	3	1

INSTRUÇÕES DE MONTAGEM ASSEMBLY'S INSTRUCTIONS INSTRUCCIONES DE MONTAJE

"IMPORTANTE LER COM ATENÇÃO E GUARDAR PARA EVENTUAIS CONSULTAS".
"IMPORTANTE LEER CON ATENCIÓN Y GUARDAR PARA EVENTUALES CONSULTAS".
"IMPORTANT TO READ CAREFULLY AND SAVE FOR ANY QUERIES".

dm
DELMARCO

1

A		CAVILHA Ø6X30 CLAVIJA Ø6X30 WOOD DOWEL Ø6X30	40
B		PARAFUSO CC 3,5X12 TORNILLO CC 3,5X12 SCREW CC 3,5X12	52
C		PARAFUSO CC 3,5X40 TORNILLO CC 3,5X40 SCREW CC 3,5X40	23
DB		DOBRADIÇA 26 CALÇO BISAGRA HINGE	08
F		PARAFUSO CF 4,5X50 TORNILLO CF 4,5X50 SCREW CF 4,5X50	05
M		PREGO 10X10 CLAVO 10X10 NAIL	75
L		CANTONERA ESQUINERO CORNER	04
U		ADESIVO TAPA FURO STICKER	11
V		COLA PEGAMENTO GLUE	01
PE		PÉ PIE FOOT	05
PX		PUXADOR TIRADOR HANDLE	04
PY		PUXADOR TIRADOR HANDLE	01
R		GARRA METAL GARRA METALICA METAL CLAW	04
Z		PARAFUSO CF 3,5X25 TORNILLO CF 3,5X25 SCREW CF 3,5X25	11
CR		CORREDIÇA 350 CORREDERA SLIDE	01
W		PARAFUSO DE UNIÃO TORNILLO UNIÓN UNION SCREW	04
E		CHAPA FIXAÇÃO PLACA DE FIJACIÓN FIXING PLATE	01

Ferramentas Necessárias:
Herramientas Necessárias:
Necessary Tools:



