

# HOME ALAGOAS

V-2 01/08/22

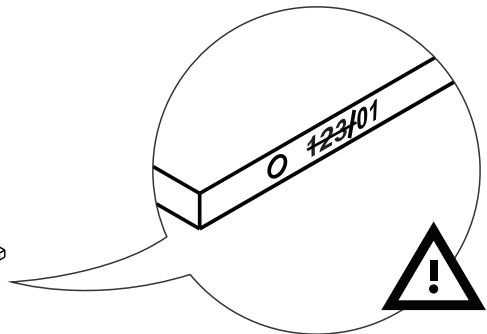
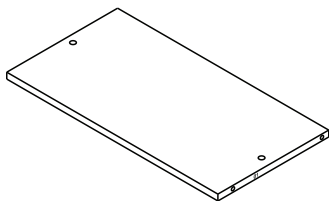
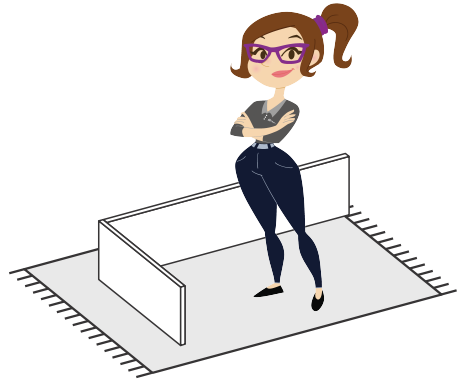
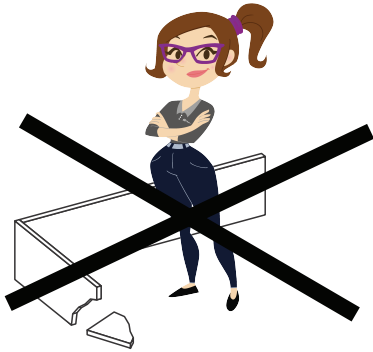
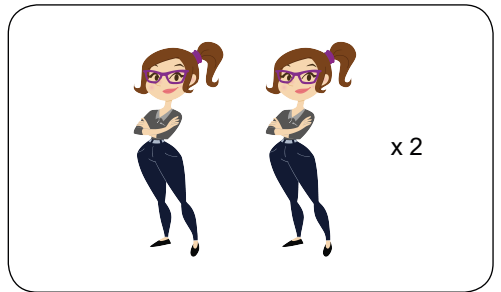
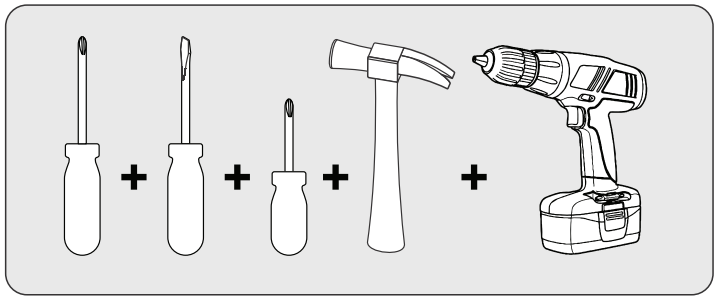
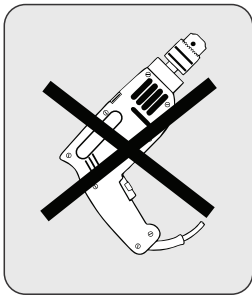

Nossos produtos são garantidos por 90 dias contra defeitos de fabricação. Ao constatar um problema coberto pela garantia, entre em contato com a loja onde o produto foi comprado. Ela estará capacitada para atendê-lo da melhor forma diante de cada caso. Reclamações de garantia somente poderão ser atendidas se o termo de garantia for apresentado no ato de reivindicação, acompanhado de sua nota fiscal de compra.

Nuestros productos están garantidos contra defectos de fabricación por 90 días, a partir de la compra. Ao constatar un problema protegido por la garantía, póngase en contacto con la tienda donde se adquirió el producto. Ella estará capacitada para atenderlo de la mejor manera de acuerdo con cada caso.

Our products are guaranteed against manufacturing defects for 90 days from the date of purchase. When you find a problem covered by the warranty, please contact the store where the product was purchased. The store be able to serve you in the best way in each case.

**Exclusões**

- Desgaste natural ou danos causados por água, maresia, ferrugem, incêndio, calor, cupins e pragas em geral
- Montagem, manutenção e uso inadequado
- Não cumprimento das recomendações técnicas do esquema
- Montagens e desmontagens após a primeira instalação
- Instalações elétricas e outras afins

**Exclusiones**

- Desgaste natural o daños causados por agua, maresia, incendios, calor, termitas y plagas en general
- Montaje, mantenimiento y uso inadecuado
- No cumplimiento de las recomendaciones técnicas del esquema
- Montaje y desmontaje después de la primera instalación
- Instalaciones eléctricas y otras afines

**Exclusions**

- Natural wear or damage caused by water, sea, rust, fire, heat, termites and plaques in general
- Assembly, maintenance and improper use
- Failure to comply with the technical recommendations of the assembly instructions
- Assembly and disassembly after first installation

**Importante**

A Linha Brasil não autoriza nenhuma pessoa, loja ou entidade assumir em seu nome qualquer outra garantia que não conste no certificado. O fabricante reserva-se no direito de efetuar nos produtos eventuais modificações que considerar necessárias, sem prejudicar as características essenciais. Os produtos terão peças de assistência para reposição no período de 1 ano a contar de sua retirada do mercado, desde que haja matéria-prima equivalente, observando o dispositivo no Art.32 da Lei 8.078/90 (Cód. Defesa do Consumidor). O atendimento para produtos fora de linha é feito por programação especial, através da loja revendedora sob aprovação de consulta prévia ao fabricante.

**Importante** / Línea Brasil no autoriza a ninguna persona, tienda o entidad a asumir in su nombre cualquier otra garantía que no figure en el certificado. El fabricante se reserva el derecho de efectuar en los productos eventuales modificaciones que considere necesarias, sin perjudicar las características esenciales. Los productos tendrán piezas de asistencia para reposición en el período de 1 año a partir de su retirada del mercado. La atención para productos fuera de línea es hecha por programación especial, a través de la tienda revendedora bajo aprobación de consulta previa al fabricante.

**Important** / Línea Brasil does not authorize any person, store or entity to assume on its behalf any other warranty that does not appear on the certificate. The manufacturer reserves the right to make in the products any modifications that it considers necessary without prejudice to the essential characteristics. The products will have replacement parts within one year of being withdrawn from the market. The service for off-line products is done by special programming, through the store reseller under prior consultation with the manufacturer.

**INSTRUÇÕES DE LIMPEZA E CONSERVAÇÃO**

**CLEAN AND PRESERVATION INSTRUCTURE / INSTRUCCIONES PARA LA LIMPIEZA Y CONSERVACION**

Para retirar pó, utilize um pano seco, espanador ou aspirador. Se necessário para uma limpeza mais efetiva, utilize um pano levemente úmido com água. Finalize com uma flanela limpa e seca.

*To take dirty, use a dry cloth, duster or vacuum. If necessary to take the dust, use a wet cloth. Finish with a clean and dry flannel.*

*Para eliminar el polvo, utilice un paño seco, mopa o la aspiradora. Si es necesario para una limpieza más eficaz, con paño ligeramente humedecido con agua. Terminar con un paño limpio y seco.*



**! IMPORTANTE / IMPORTANT / IMPORTANTE**

Não utilize produtos abrasivos como álcool e detergentes, como também esponjas rígidas ou palhas de aço na limpeza dos móveis.

*Do not use abrasives such as alcohol and detergent, though soaker also steel wool to clean the furniture.*

*No use limpiadores abrasivos como alcohol y detergentes, así como esponjas rígidas o lana de acero para limpiar los muebles.*



Proteja a superfície do móvel de objetos que transmitam calor ou umidade.

*Protect the surface of the furniture against objects that can pass heat and humidity.*

*Proteja la superficie del mueble de objetos que transmitan calor o humedad.*



Evitar o contato de água e produto de limpeza com o rodapé do produto, pois poderá danificá-lo.

*Avoid the contact of water and cleaning products with baseboard, cause it should damage your product.*

*Evitar el contacto con agua y producto de limpieza con el rodapié del producto, pues podrá dañarlo.*



Procure sempre utilizar flanela limpa e seca para limpeza.

*Try always to use a clean and dry flannel to cleaning.*

*Busque siempre utilizar franela limpia y seca para la limpieza.*



Cuidado com objetos pontiagudos, eles podem arranhar a superfície das portas e tampo.

*Take care with sharp objects, they can scratch the door lid surface.*

*Cuidado con objetos afilados, ellos pueden rayar la superficie de las puertas y la tapa.*

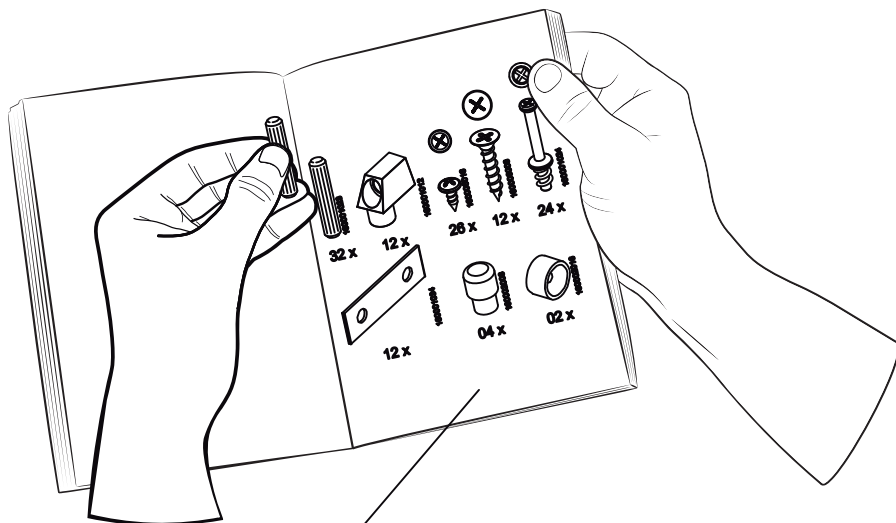

## Preste Atenção! ¡Preste atención! Attention!



As ferragens dos nossos manuais são sempre apresentadas nas mesmas proporções da peça na vida real.  
Caso apareça alguma dúvida no decorrer do processo de montagem, coloque a ferragem ao lado do desenho e faça a consulta :D

Los accesorios de nuestros manuales siempre se presentan en las mismas proporciones que la pieza en la vida real.  
Si tiene alguna duda durante el proceso de montaje, coloque los accesorios junto al dibujo y haga una consulta :D

The accessories in our manuals are always presented in the same proportions as the spare part in real life.  
If you have any questions during the assembly process, place the accessory next to the drawing and make an inquiry :D

## Símbolos: Símbolos: Symbols:



- + Parafuso Phillips
- Parafuso Fenda
- ⬡ Parafuso Allen

- + Tornillo Phillips
- Tornillo Ranurado
- ⬡ Tornillo Allen

- + Phillips screw
- Slotted Screw
- ⬡ Allen screw

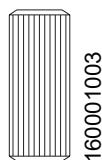

160001003

02 x

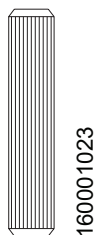

160001023

42 x

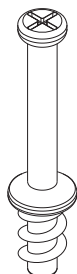

160001024

32 x



160006016

186 x

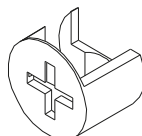

160001025

32 x

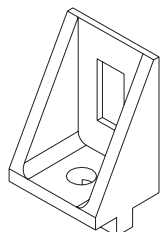

160001011

08 x



160002015

04 x

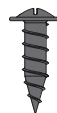

160006003

04 x



160006006

21 x

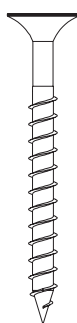

160006010

04 x



160006020

02 x



160006022

02 x

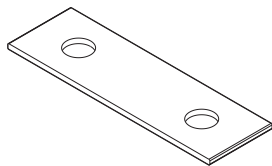

160001034

20 x

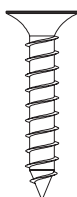

160006008

07 x



160006011

49 x



160001002

13 x



160001022

04 x

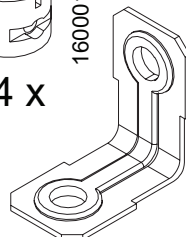

160001040

02 x

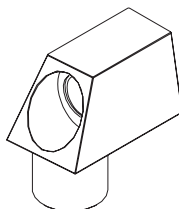

160001012

02 x

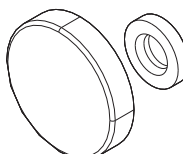

160005056

02 x

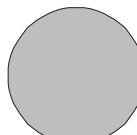

160002002

16 x

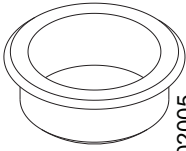

01 x

160002005



02 x

160005055

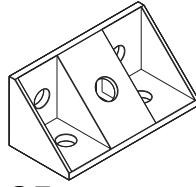

25 x

160001018

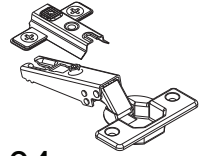

04 x

160003003

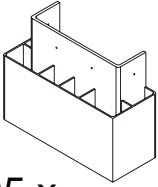

05 x

160009010

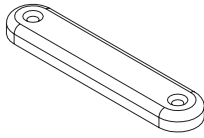

06 x

160002004

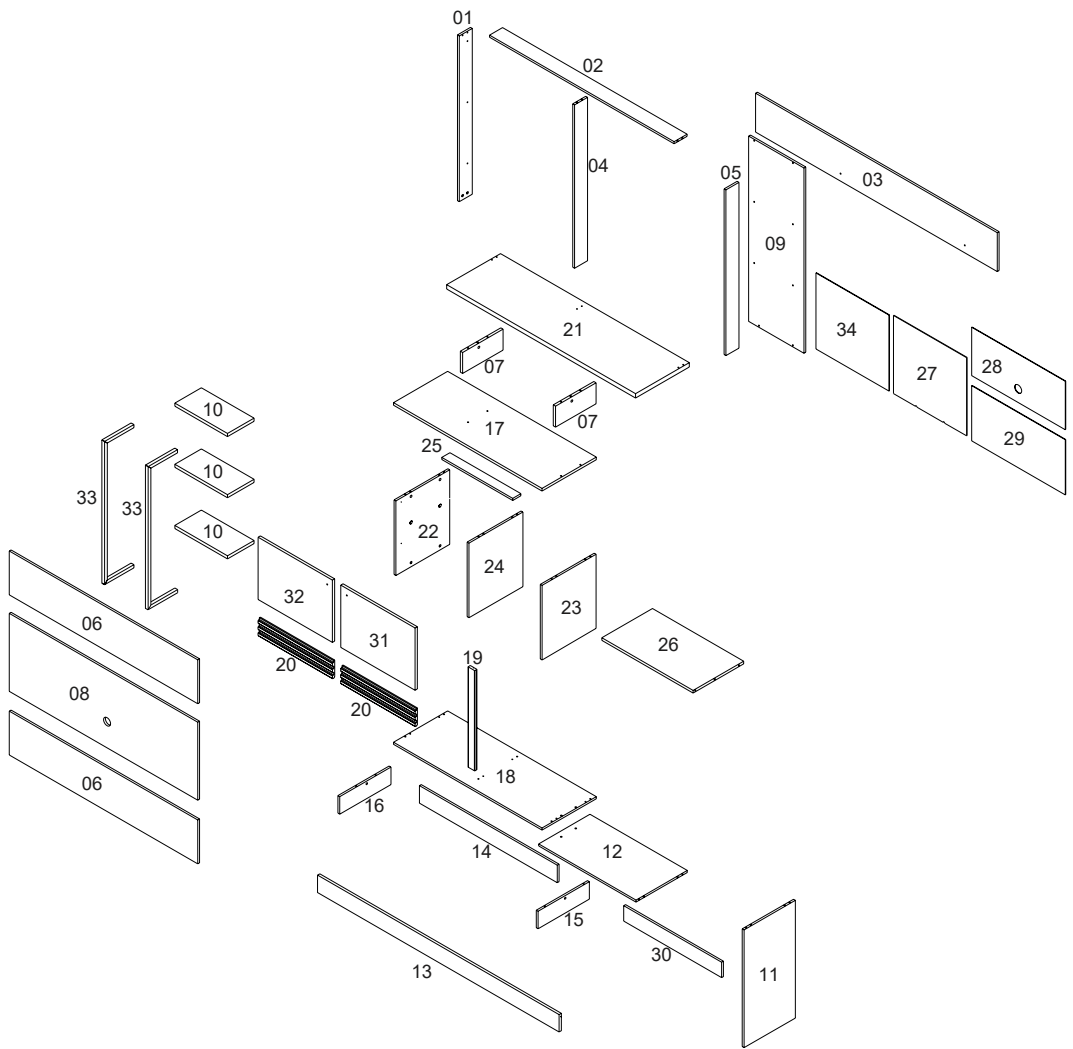

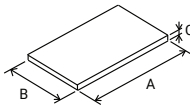

VOLUME Caja Box	ITEM Artículo Item	PEÇA Pieza Part	DESCRIPCIÓN Descripción Description	DIMENSÕES (mm) Dimensión/Dimension			QUANTIDADE La Cantidad The Amount	MATERIAL
				A	B	C		
1	1	510258001	TRAVESSA ESQUERDA	949	86	12	1	MDP
1	2	510258002	TRAVESSA SUPERIOR	1220	86	12	1	MDP
1	3	510258003	PAINEL SUPERIOR	1598	223	12	1	MDP
1	4	510258004	TRAVESSA CENTRAL SUPERIOR	935	86	12	1	MDP
2	5	510258005	TRAVESSA DIREITA	949	86	12	1	MDP
2	6	510258006	PAINEL INFERIOR SUPERIOR	1247	252	12	2	MDP
1	7	510258007	DIVISAO DVD	268	120	15	2	MDP
1	8	510258008	PAINEL CENTRAL TV	1247	447	12	1	MDP
1	9	510258009	PAINEL ESQUERDO	1060	366	12	1	MDP
1	10	510258010	PRATELEIRA SUPERIOR ESQUERDA	349	176	18	3	MDF
1	11	510258011	LATERAL DIREITA	674	339	12	1	MDP
1	12	510258012	BASE	643	339	12	1	MDP
1	13	510258013	ENCABECAMENTO BASE	1598	100	15	1	MDP
2	14	510258014	RODAPE TRASEIRO ESQUERDO	911	100	12	1	MDP
2	15	510258015	RODAPE CENTRAL	339	100	12	1	MDP
2	16	510258016	RODAPE LATERAL	339	100	12	1	MDP
2	17	510258017	TAMPO PORTA	983	359	15	1	MDP
2	18	510258018	BASE PORTA	983	359	12	1	MDP
1	19	510258019	ENCABECAMENTO LATERAL DIREITO	574	44	15	1	MDF
1	20	510258020	MOLDURA PORTA	492	101	15	2	MDF
2	21	510258021	TAMPO TV	1249	356	25	1	MDP
1	22	510258022	LATERAL PORTA ESQUERDA	427	357	12	1	MDP
1	23	510258023	LATERAL PORTA DIREITA	427	357	12	1	MDP
2	24	510258024	DIVISAO PORTA	427	357	12	1	MDP
1	25	510258025	SUPORTE TAMPO ESQUERDO	469	54	12	1	MDP
2	26	510258026	PRATELEIRA DIREITA	603	335	15	1	MDP
1	27	510258027	FUNDO TRASEIRO PORTA DIR. (COM FURO)	483	447	2.8	1	MDF
1	28	510258028	FUNDO TRASEIRO DIR. SUP. (COM FURO)	619	277	2.8	1	MDF
2	29	510258029	FUNDO TRASEIRO DIREITO INFERIOR	619	316	2.8	1	MDF
1	30	510258030	RODAPE TRASEIRO DIREITO	647	88	12	1	MDP
2	31	510258031	PAINEL PORTA DIREITA	492	357	15	1	MDP
2	32	510258032	PAINEL PORTA ESQUERDA	492	357	15	1	MDP
1	33	510258033	HASTE	820	194	18	2	MDF
1	34	510258034	FUNDO TRASEIRO PORTA ESQUERDA	486	435	2.8	1	MDF

ARTÍCULO	DESCRIPCIÓN
1	PLATO IZQUIERDO
2	PLATO ARRIBA
3	PANEL SUPERIOR
4	PLATO CENTRAL SUPERIOR
5	PLATO DERECHO
6	PANEL INFERIOR SUPERIOR
7	DIVISION DVD
8	PANEL CENTRAL TV
9	PANEL IZQUIERDO
10	ESTANTE ARRIBA IZQUIERDA
11	LATERAL DERECHA
12	BASE
13	ENCABECAMENTO BASE
14	ZÓCALO TRAZERO IZQUIERDO
15	ZÓCALO CENTRAL
16	ZÓCALO LATERAL
17	BASE PUERTA
18	BASE PUERTA
19	ENCABECAMENTO LADO IZQUIERDO
20	MARCO PUERTA
21	BASE TV
22	LATERAL PUERTA IZQUIERDA
23	LATERAL PUERTA DERECHA
24	DIVISION PUERTA
25	APOYO BASE IZQUIERDA
26	ESTANTE DERECHA
27	FONDO TRASERO PUERTA DERECHA
28	FONDO TRASERO DERECHO ARRIBA
29	FONDO TRASERO DERECHO ABAJO
30	ZÓCALO TRASERO DERECHO
31	PANEL PUERTA DERECHA
32	PANEL PUERTA IZQUIERDA
33	PROVENIR
34	FONDO TRASERO PUERTA IZQUIERDA

ITEM	DESCRIPTION
1	LEFT PLATTER
2	UPPER PLATTER
3	UPPER PANEL
4	CENTER UPPER PLATTER
5	RIGHT PLATTER
6	BOTTON UPPER PLATTER
7	DIVISION DVD
8	CENTRAL PANEL TV
9	LEFT PANEL
10	UPPER LEFT SHELF
11	RIGHT SIDE
12	BASE
13	BASE HEADING
14	BOTTOM LEFT BASEBOARD
15	CENTER BASEBOARD
16	SIDE BASEBOARD
17	BASE DOOR
18	BASE DOOR
19	RIGHT SIDE HEADING
20	FRAME DOOR
21	BASE TV
22	LEFT SIDE DOOR
23	RIGHT SIDE DOOR
24	DOOR DIVISION
25	SUPPORT LEFT BASE
26	RIGHT SHELF
27	BOTTON RIGHT DOOR
28	UPPER BOTTON RIGHT
29	LOW BOTTON RIGHT
30	RIGHT BOTTON BASEBOARD
31	RIGHT PANEL DOOR
32	LEFT PANEL DOOR
33	STEM
34	BOTTON LEFT DOOR



# 1

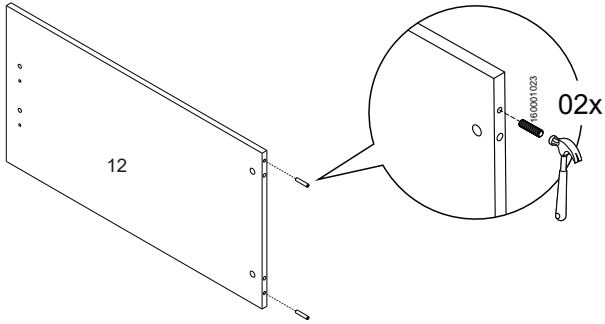
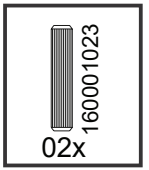

# 2

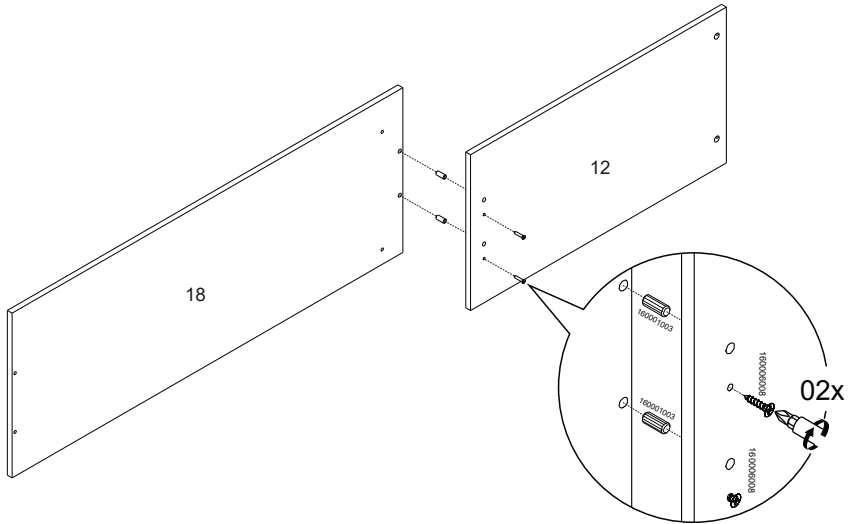
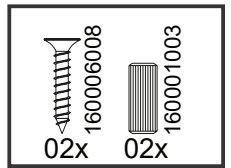

# 3

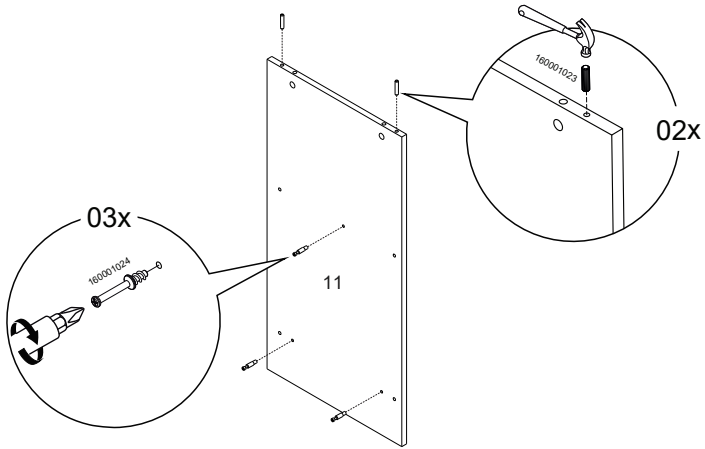
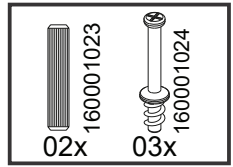

# 4

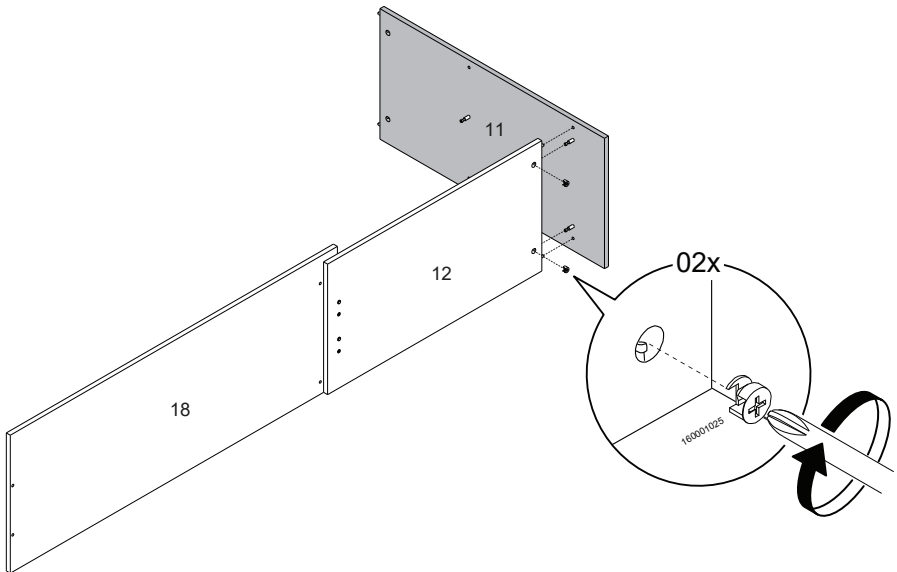
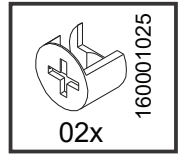
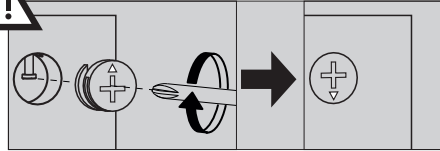

# 5

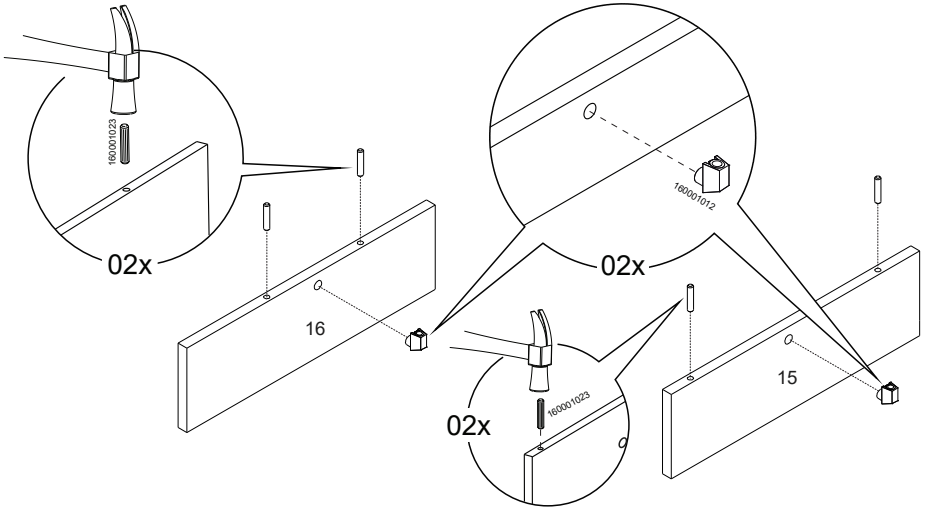
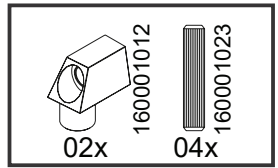

# 6

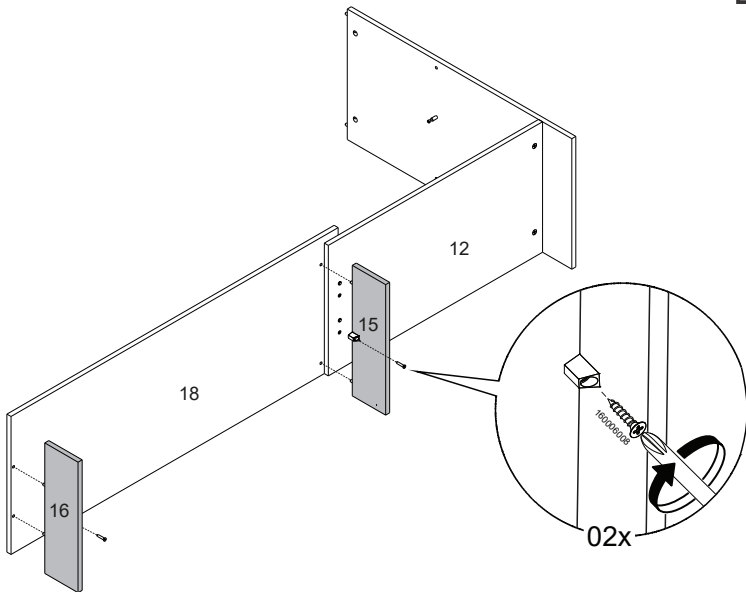
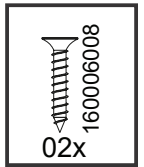

# 7

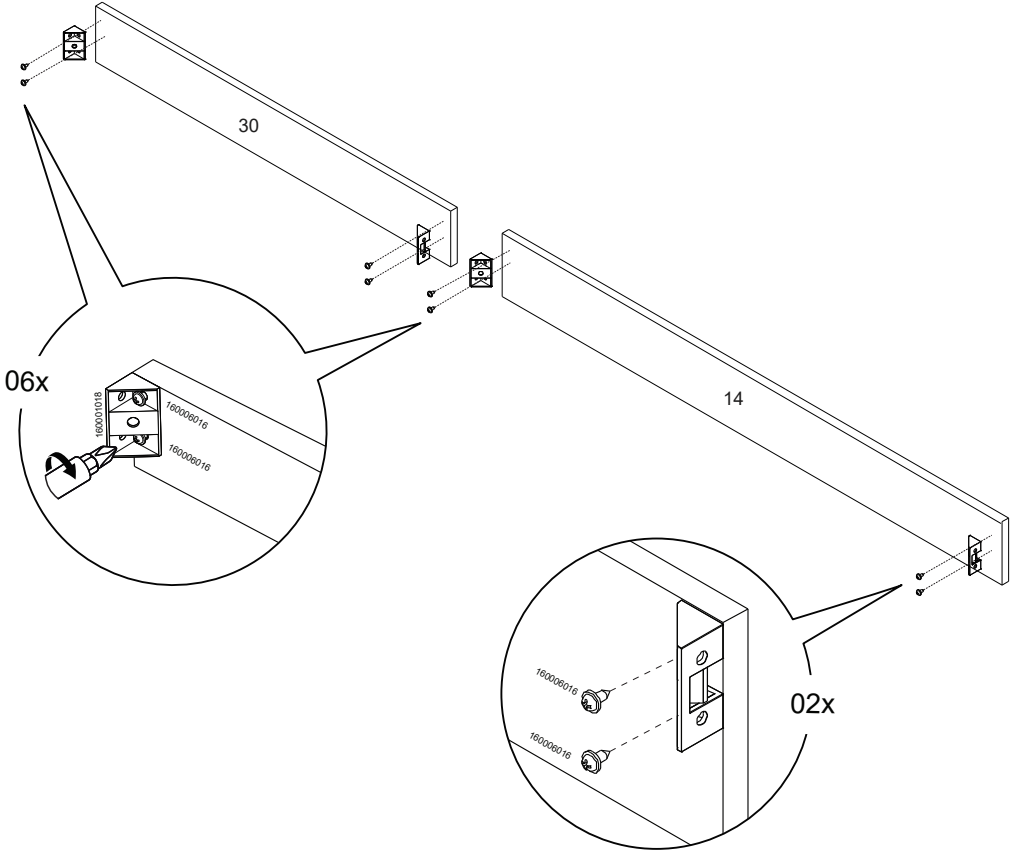
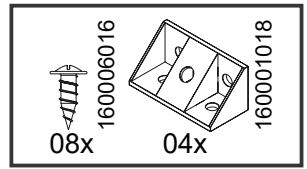

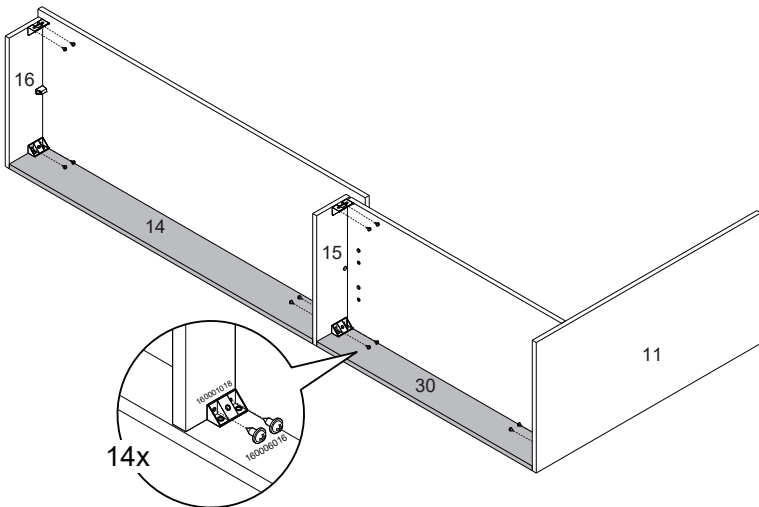
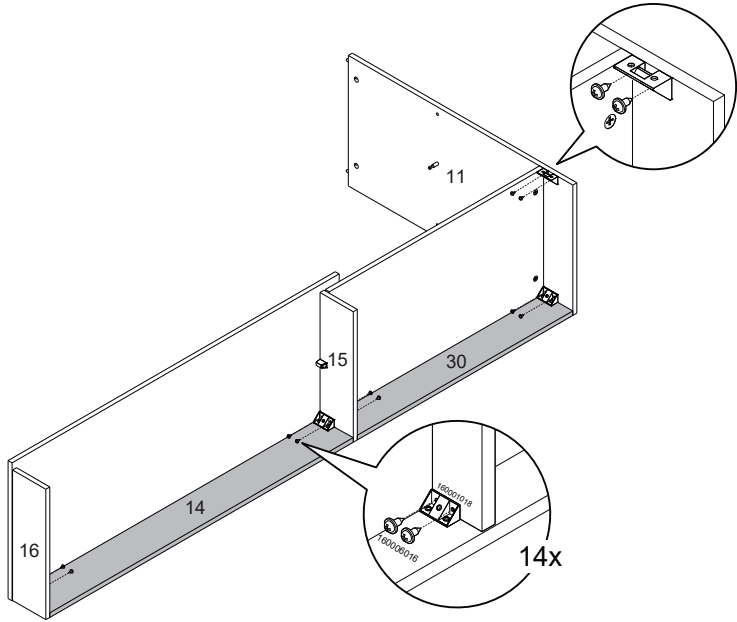
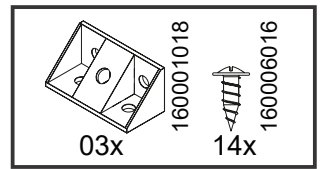

# 9

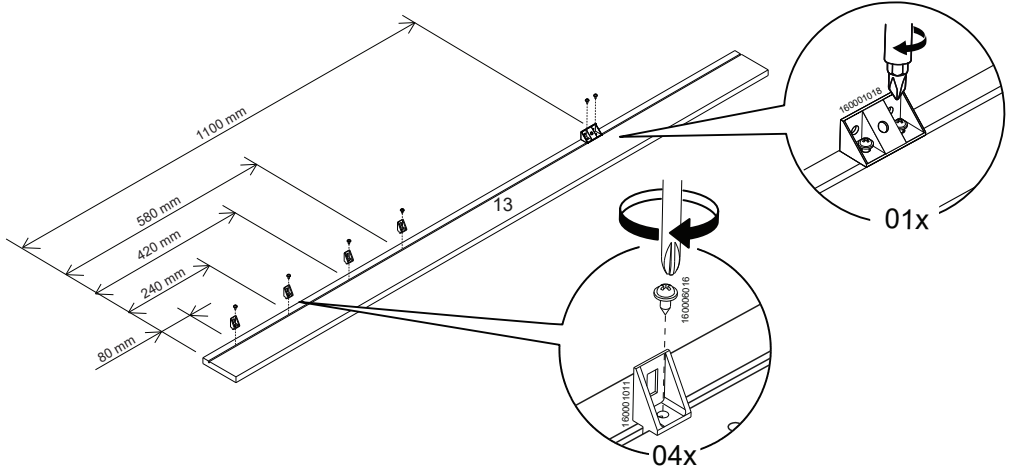
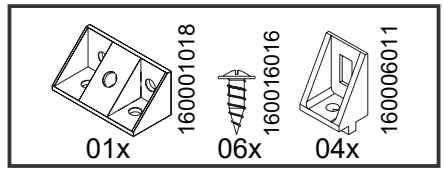

# 10

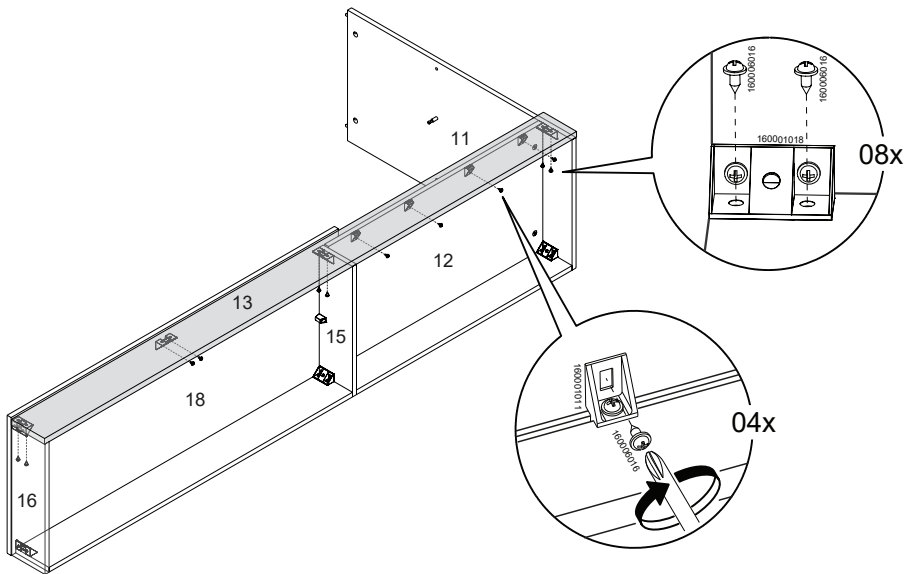
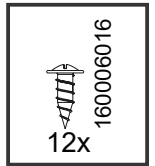

# 11



Pés opcionais  
Optional feet  
Pies opcionales

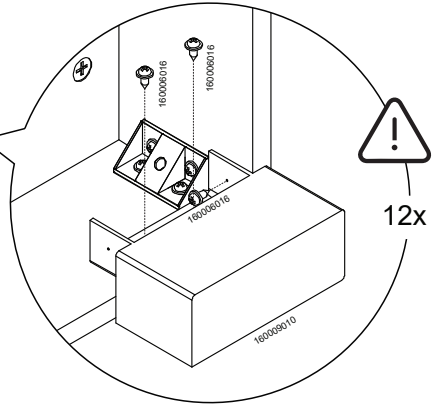
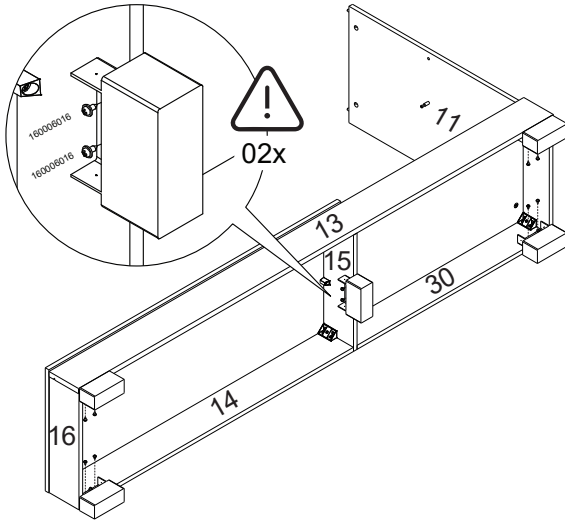
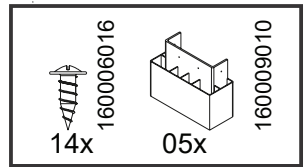

# 12

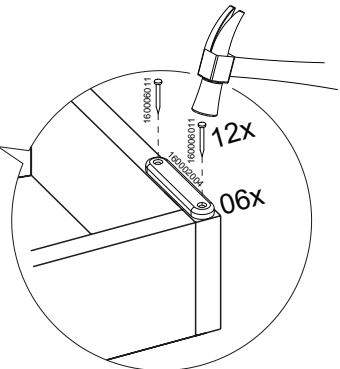
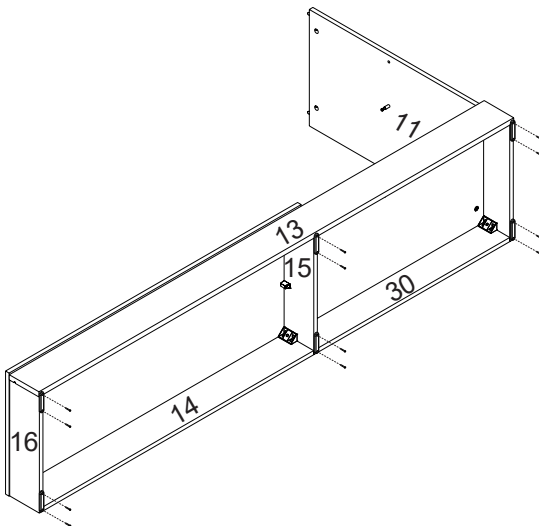
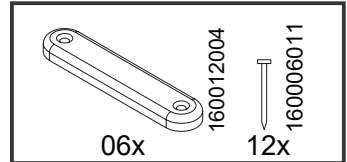

# 13

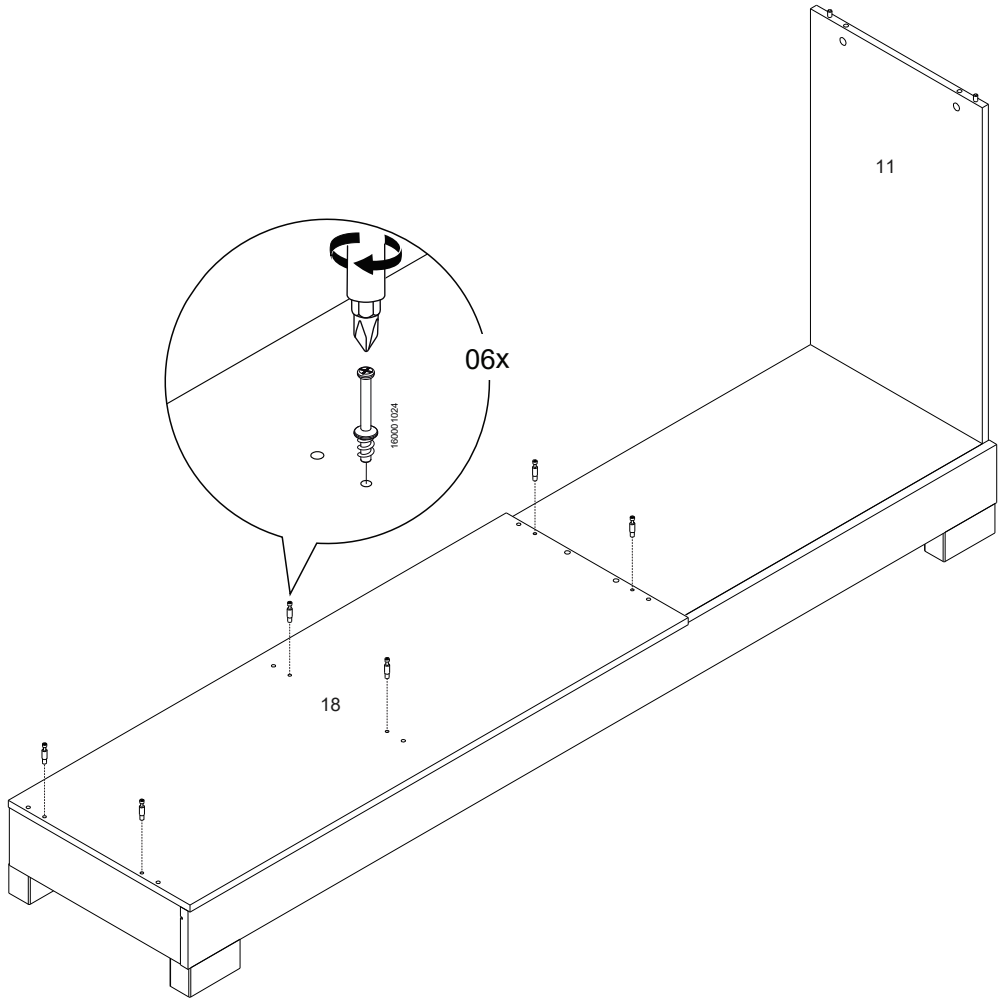
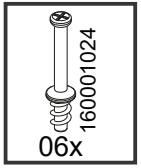



# 14

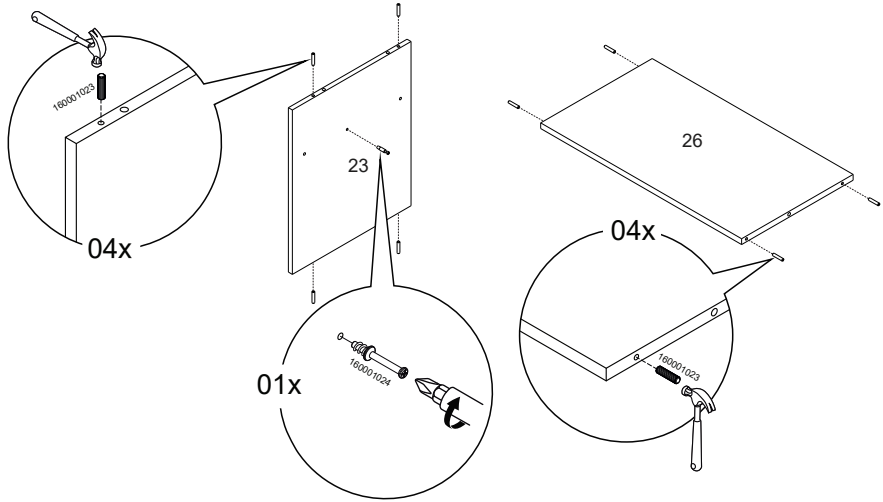
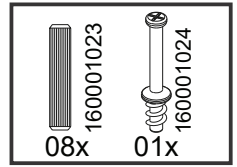

# 15

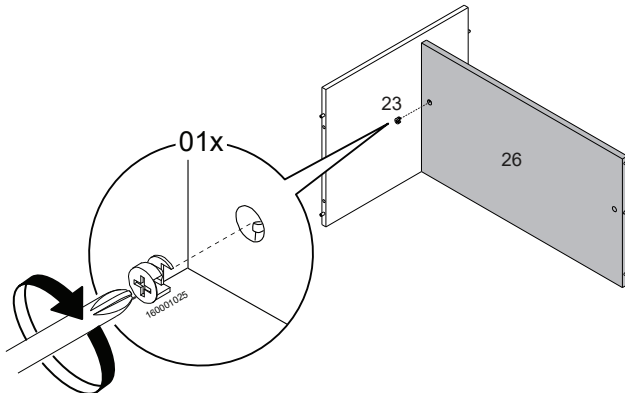
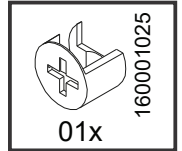
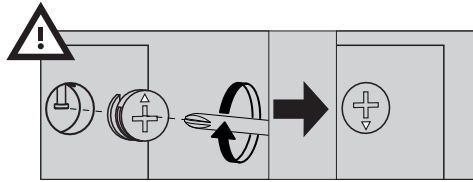

# 16

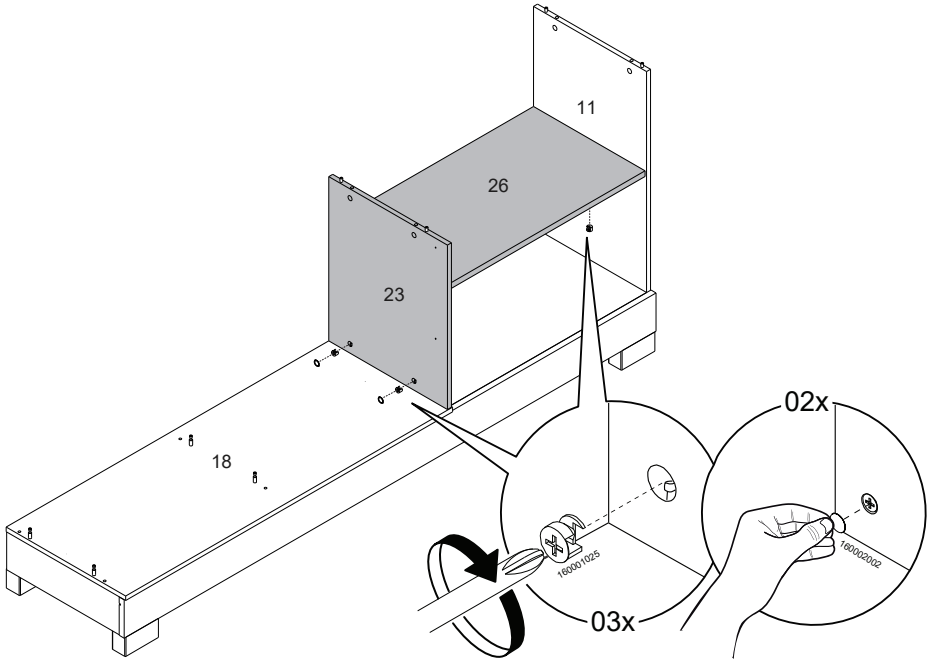
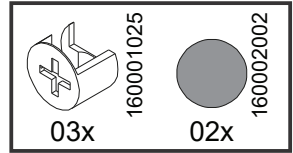
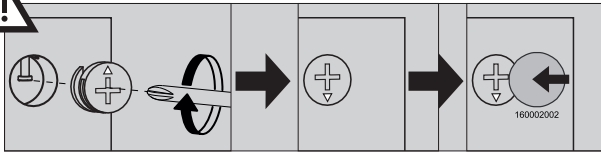

# 17

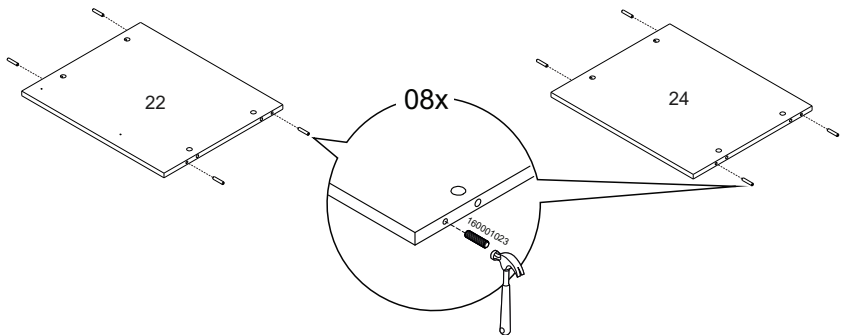
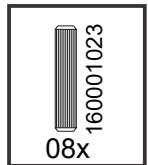

# 18

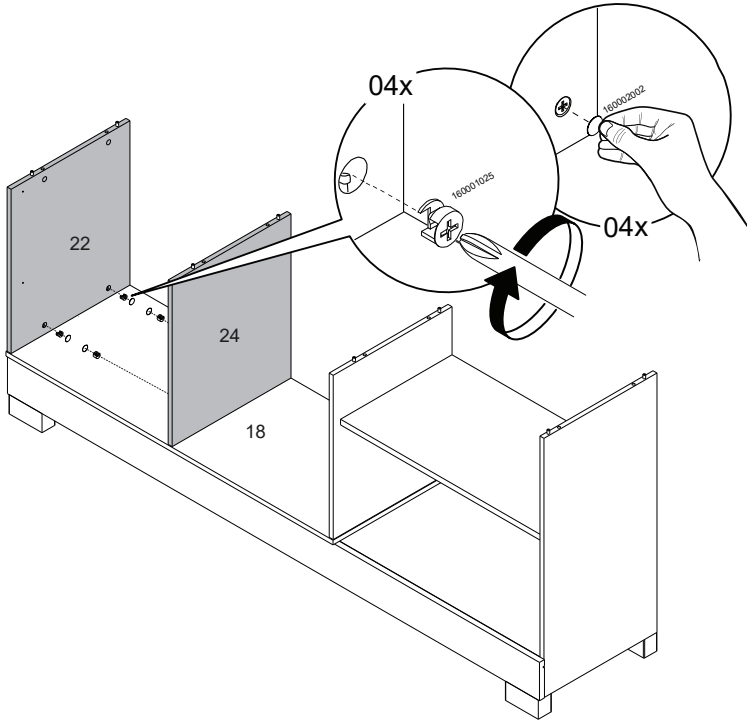
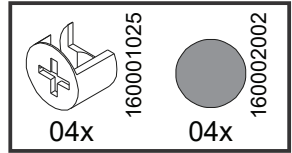
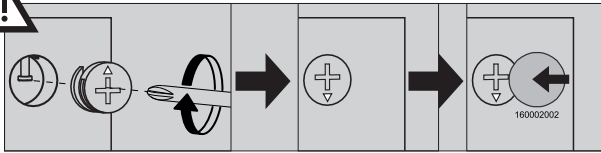

# 19

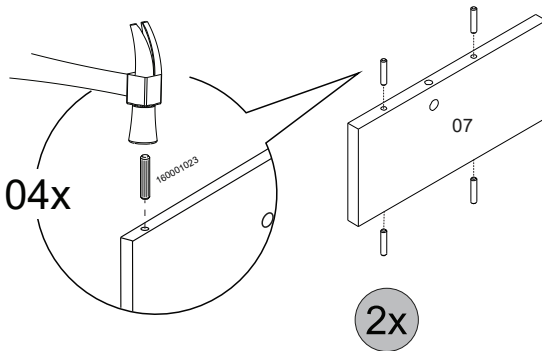
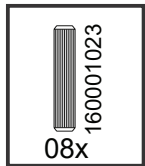

# 20

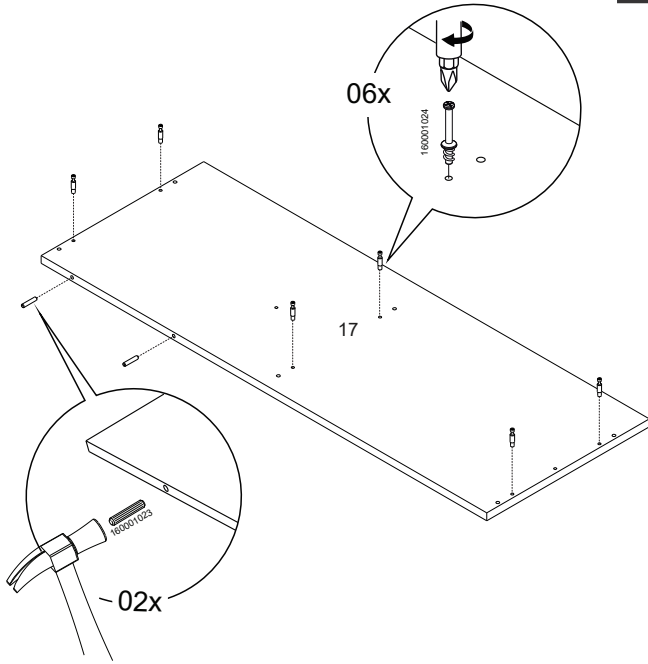
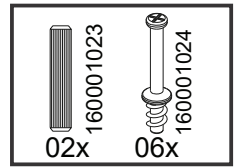

# 21

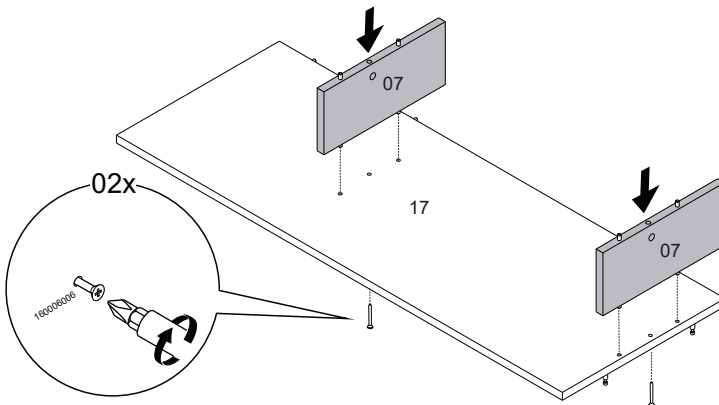
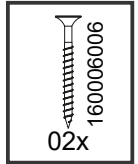

# 22

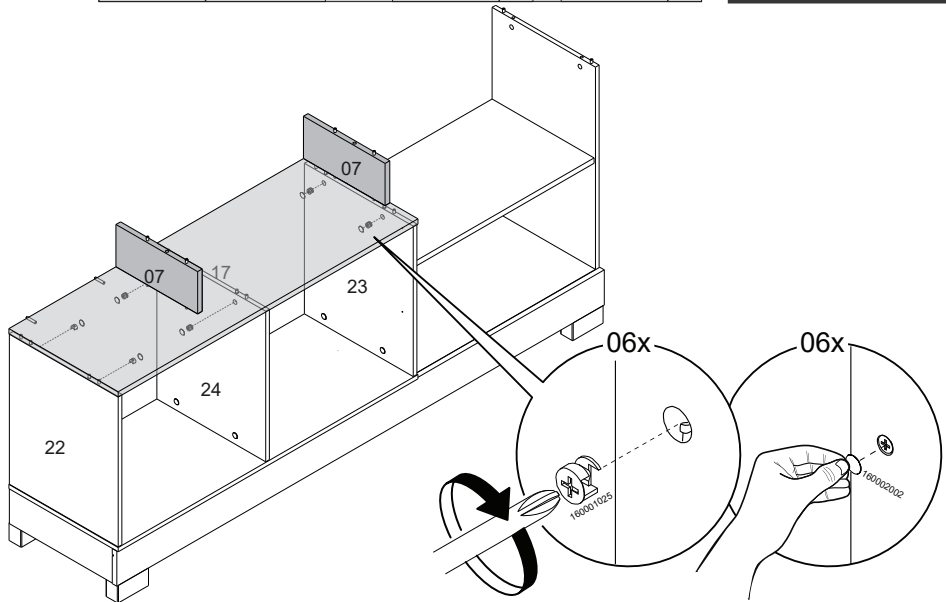
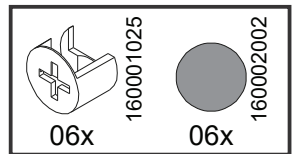
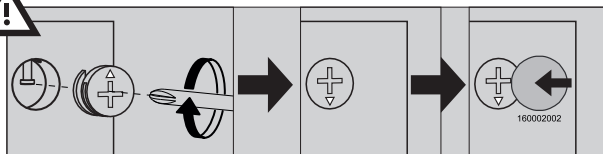

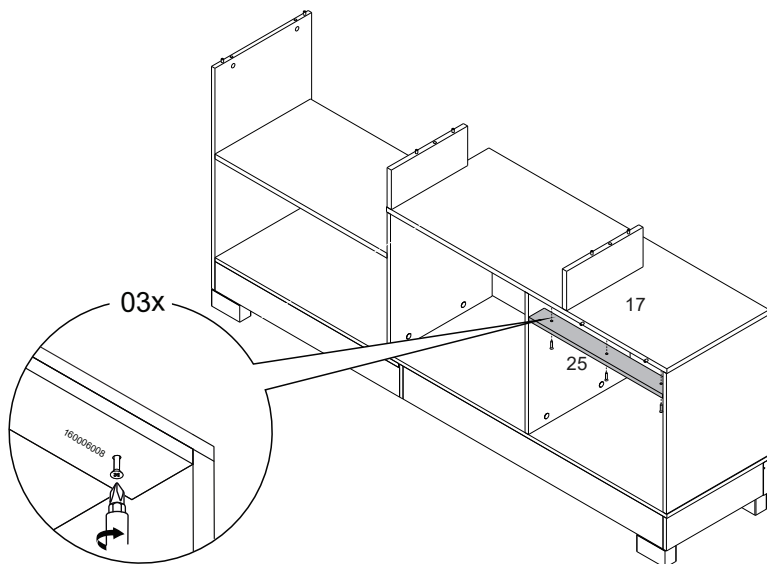
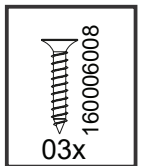

# 23

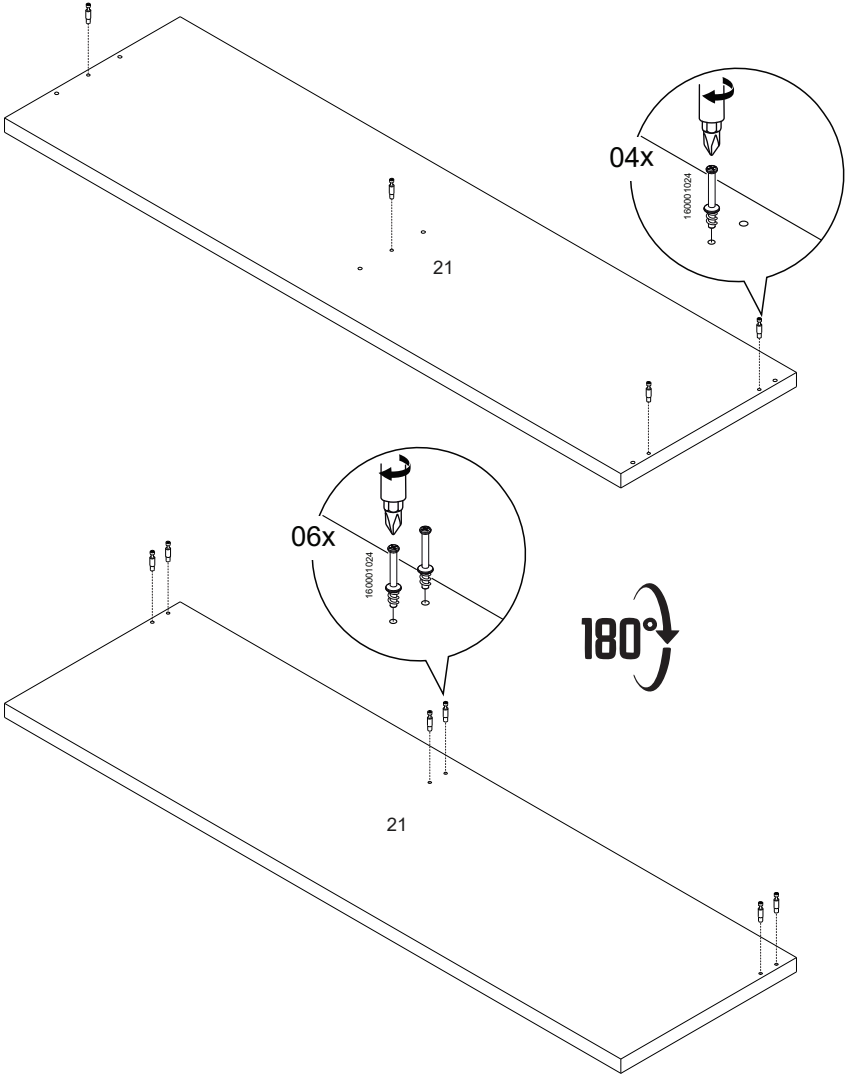
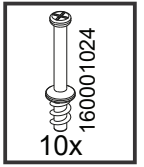



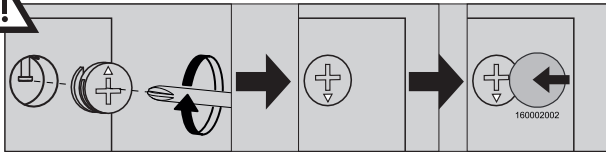

# 25

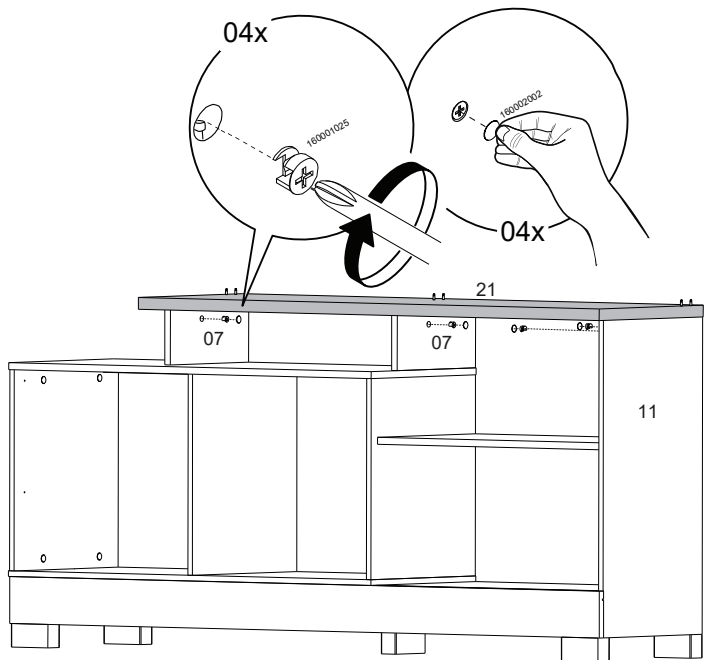

	160001025		160002002
04x		04x	



# 26

	160016016		160006011
04x		04x	

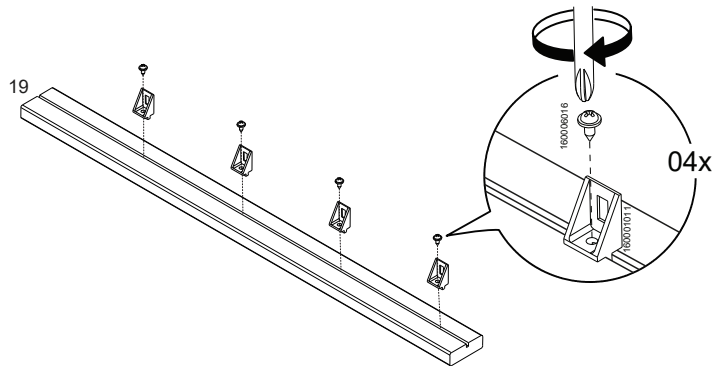

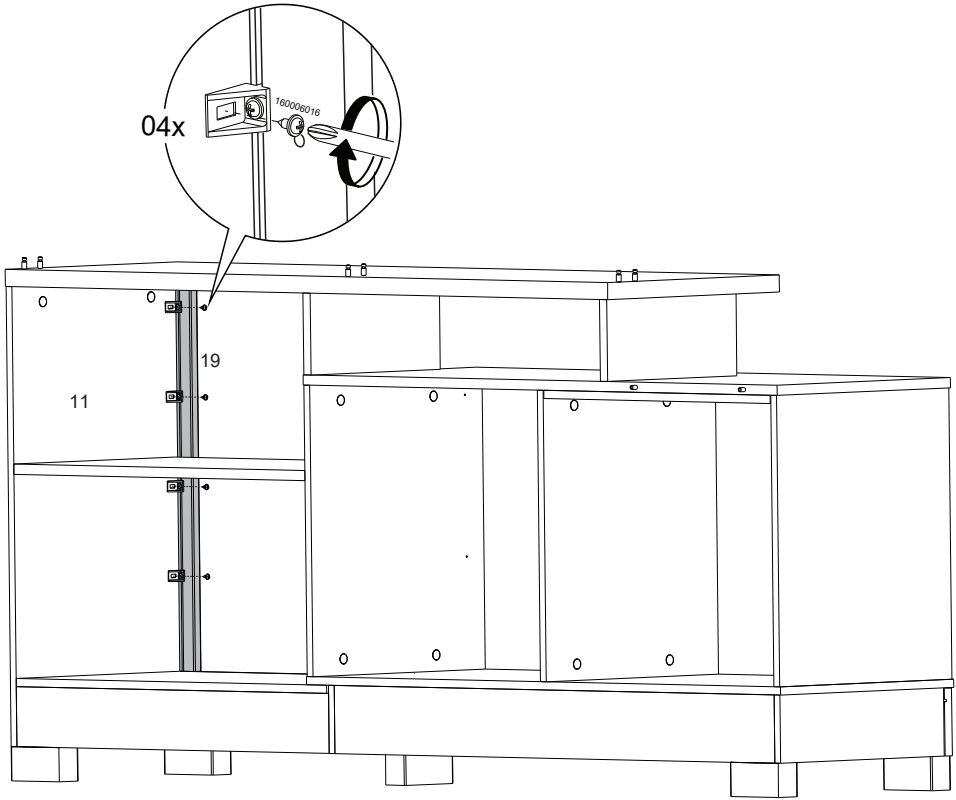



# 28

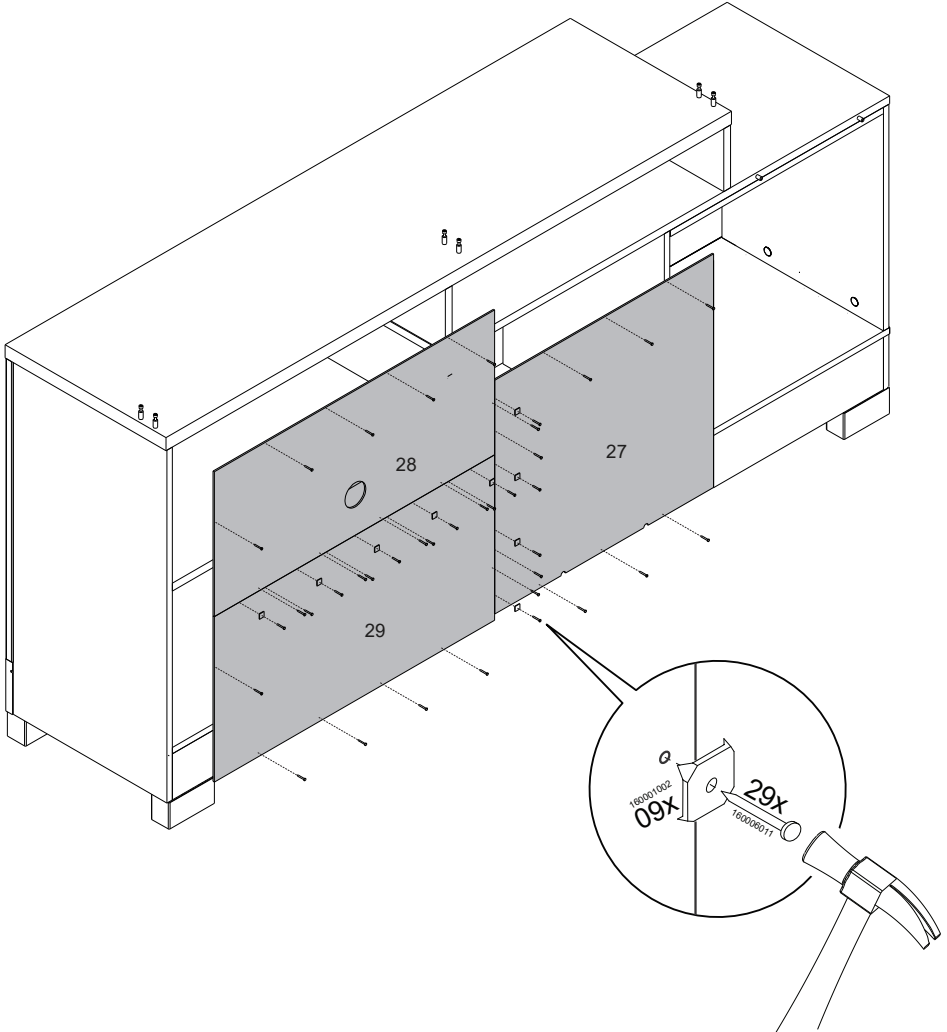
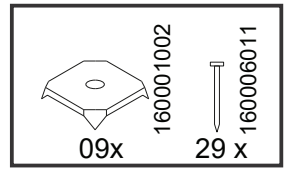

# 29

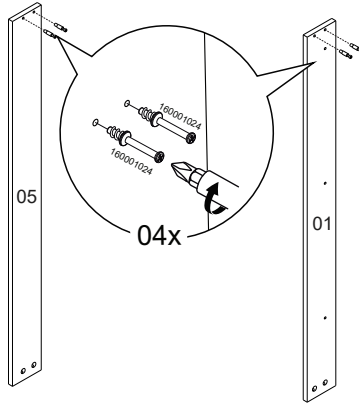
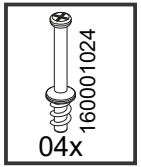

# 30

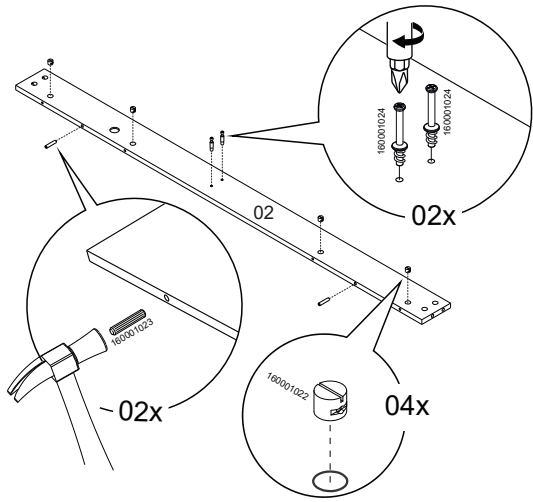
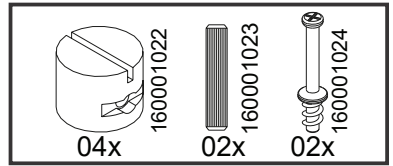

# 31

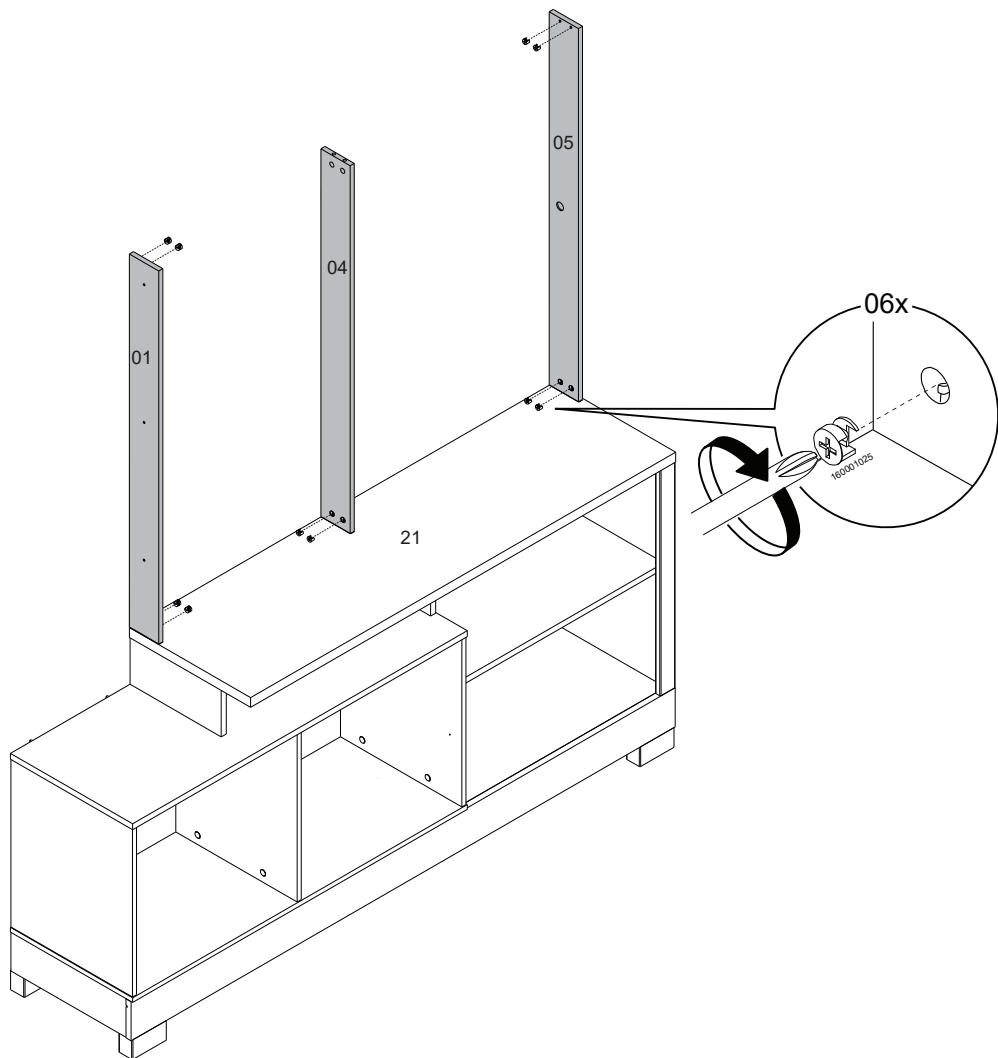
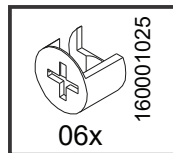
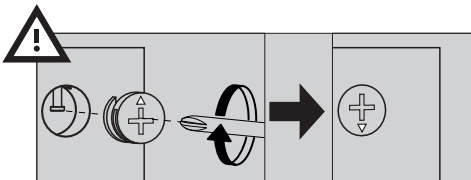

# 32

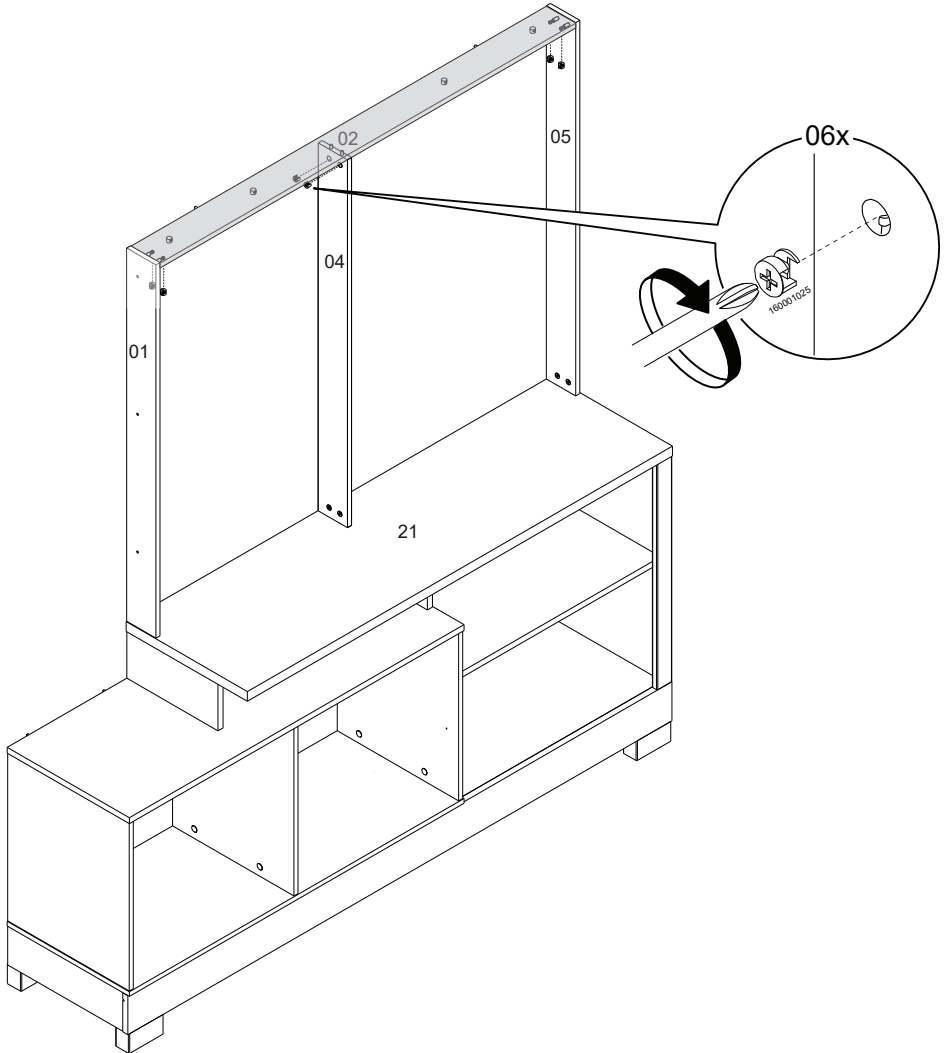
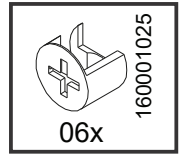
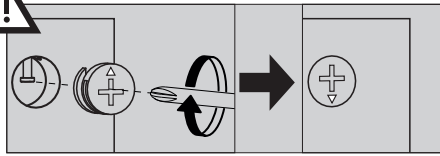

# 33

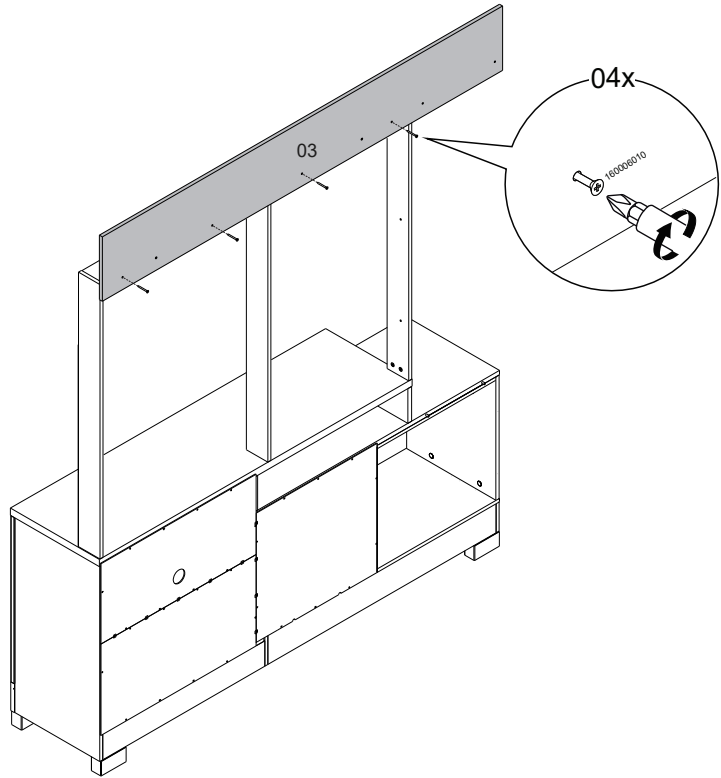
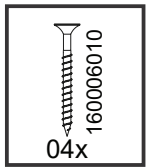

# 34

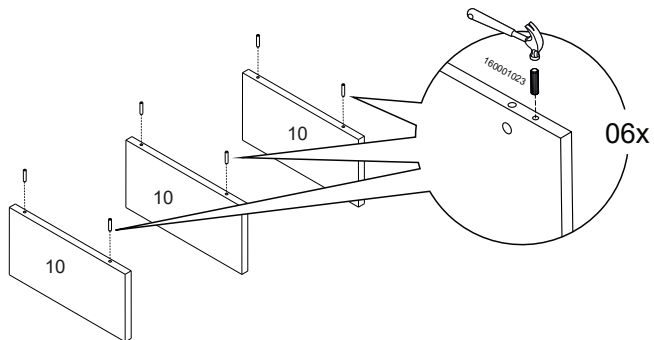
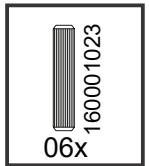

# 35

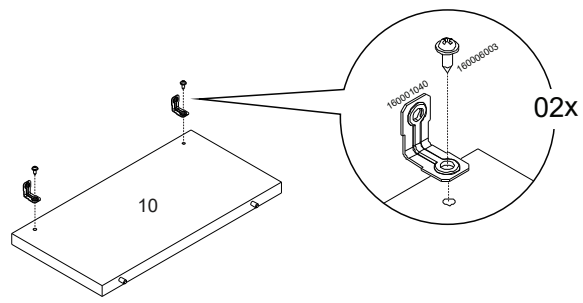
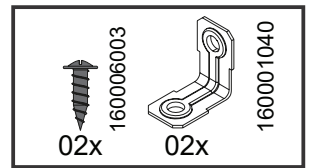

# 36

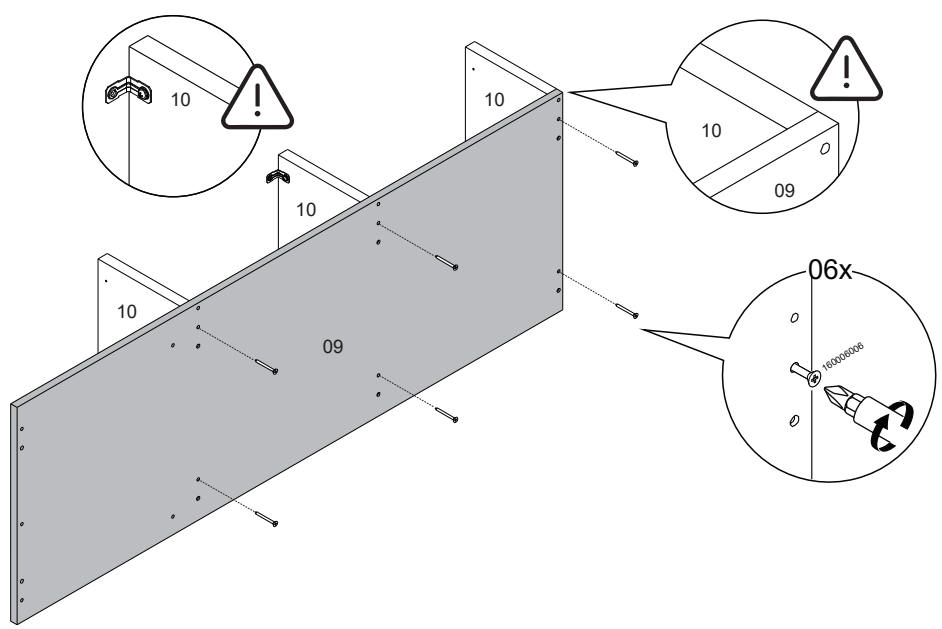
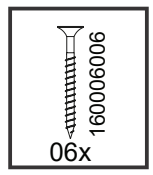

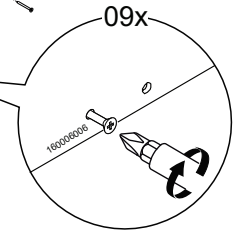
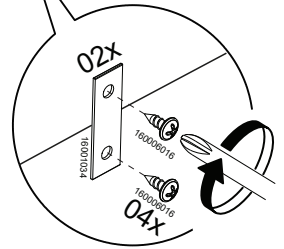
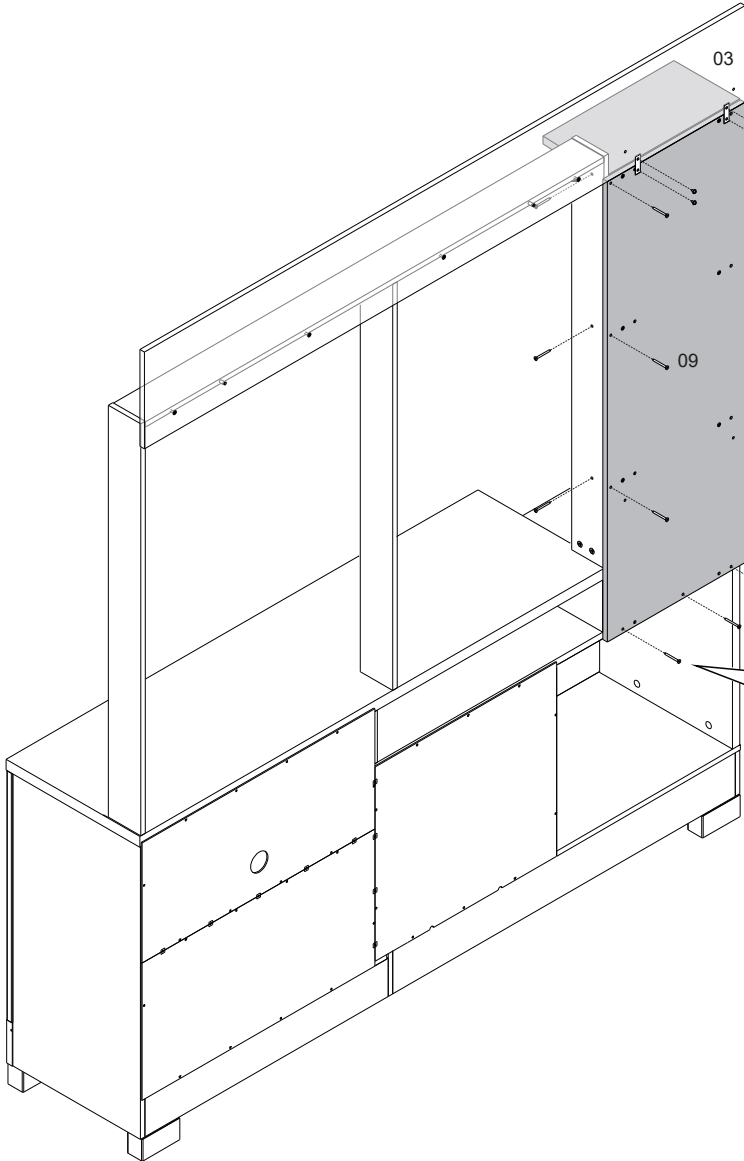
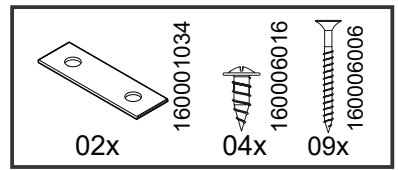

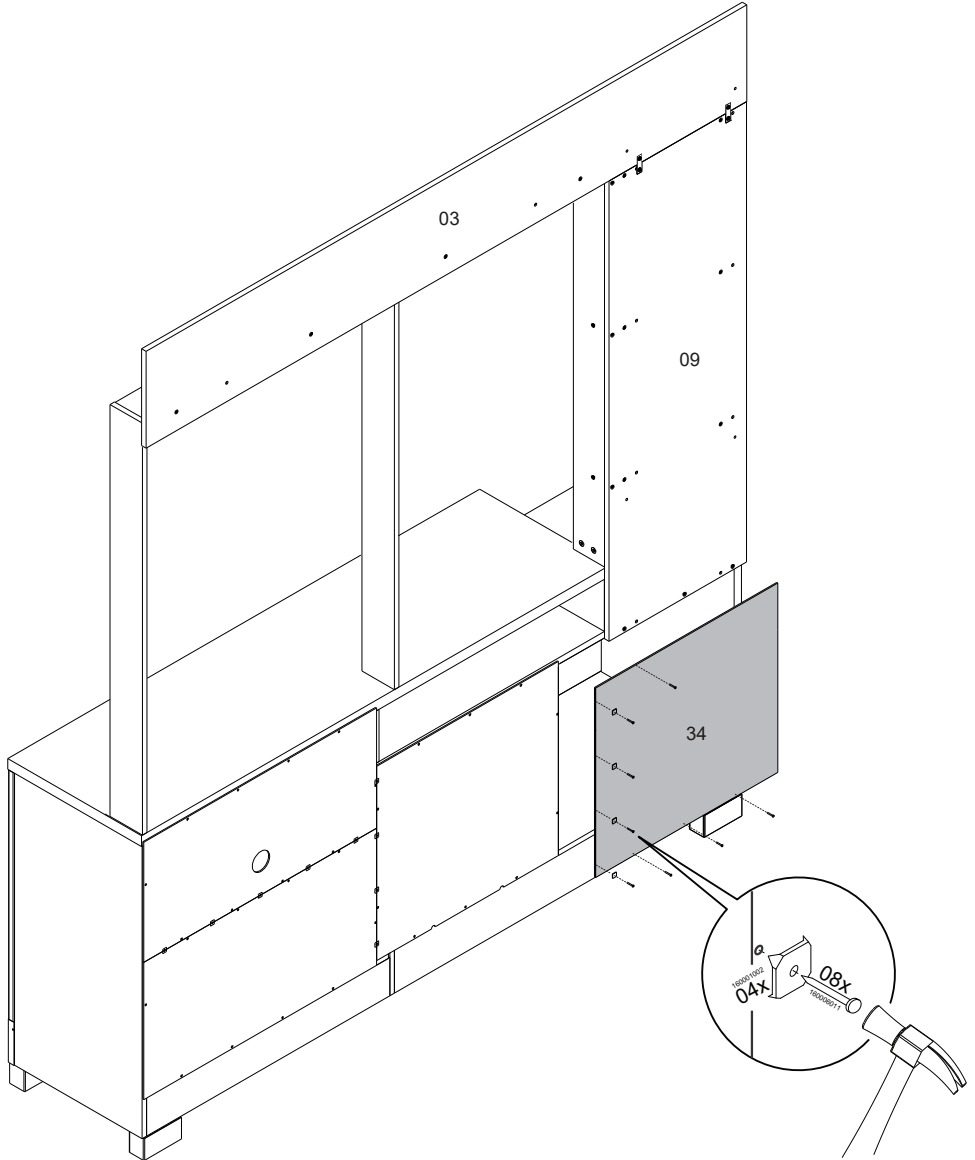
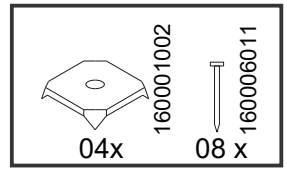



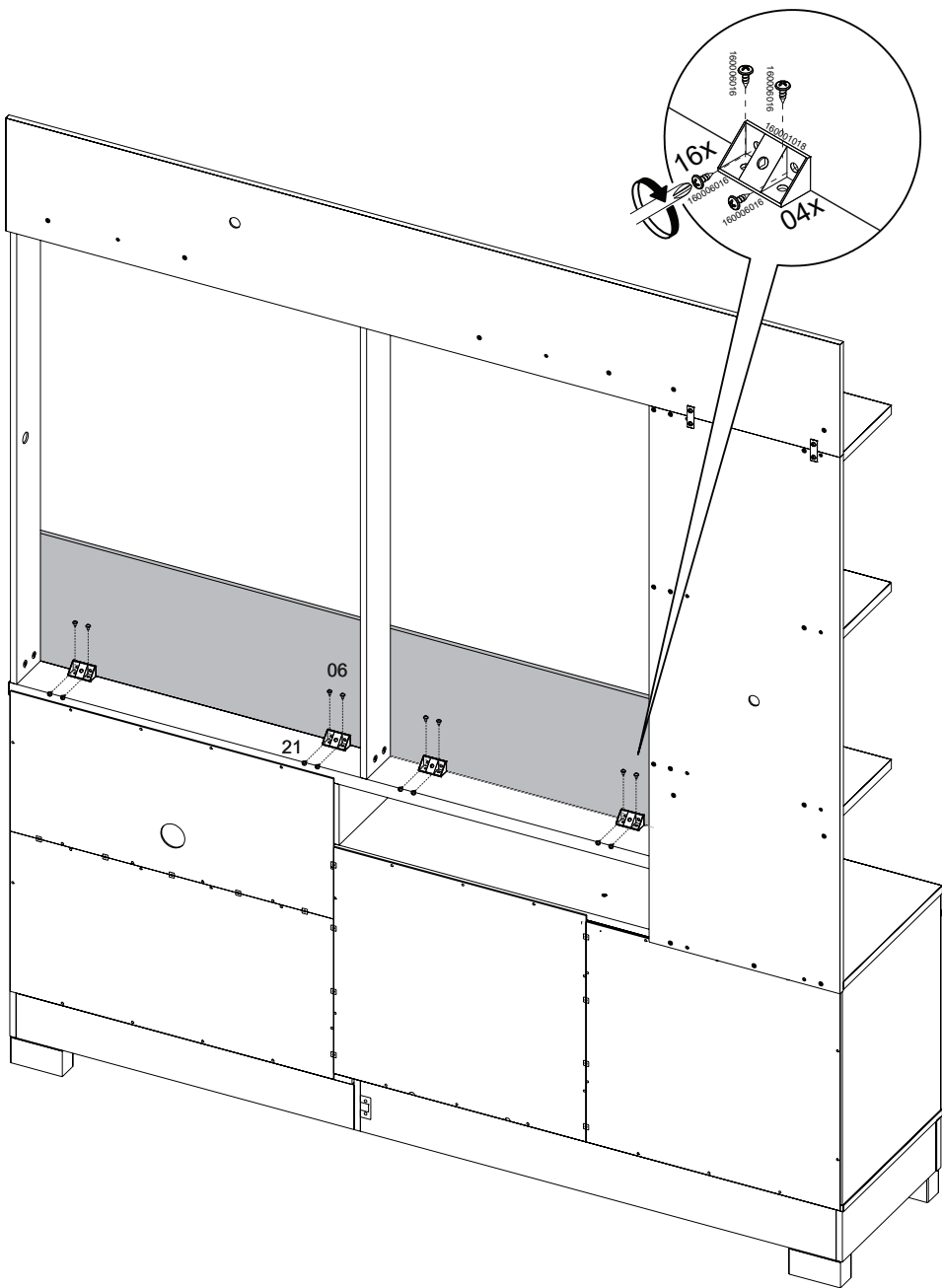
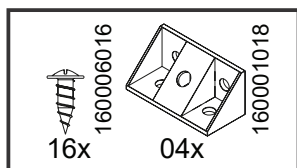

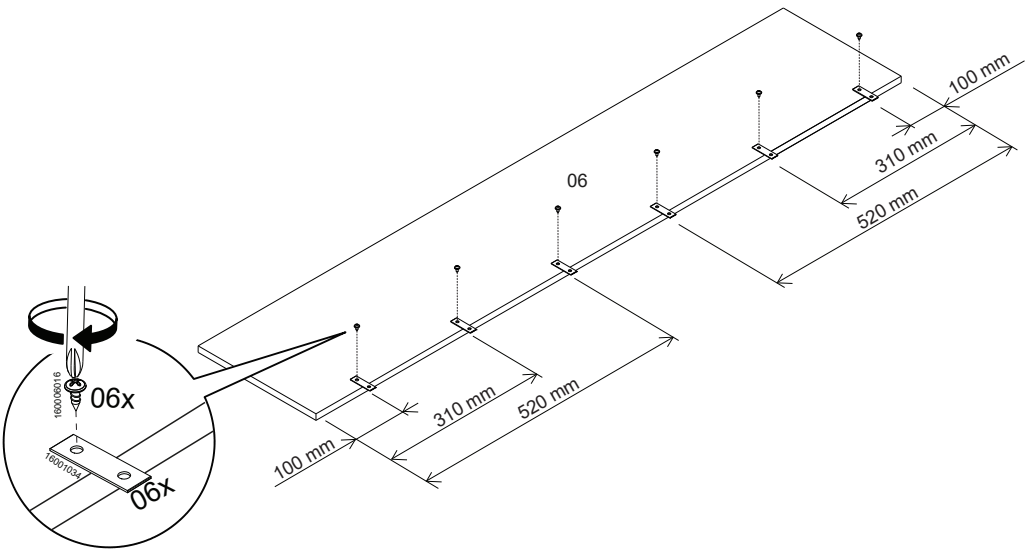
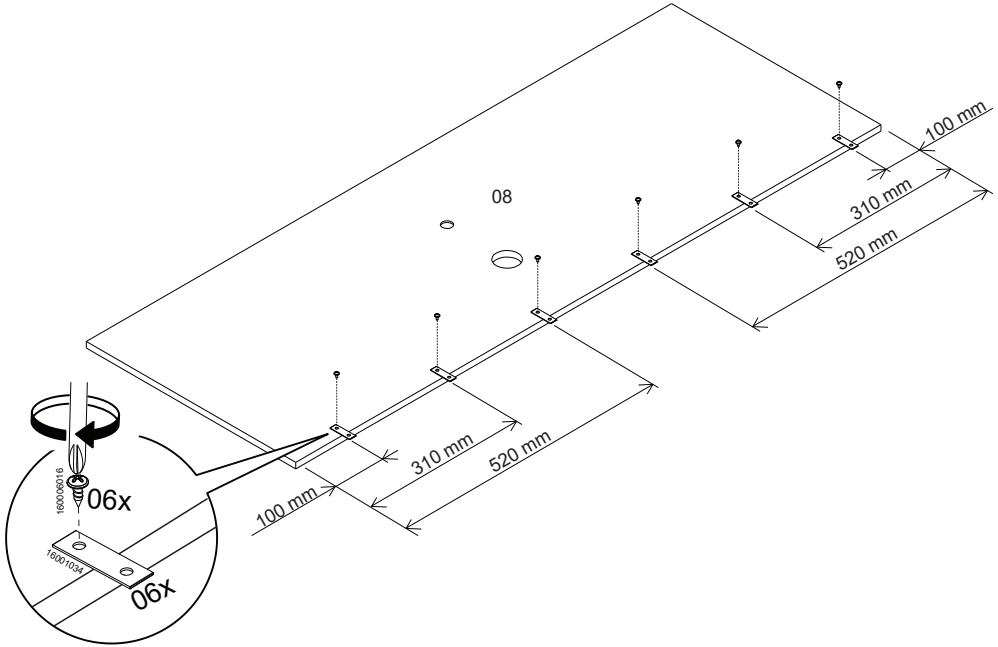
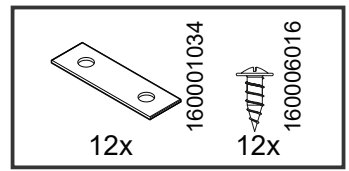

# 41

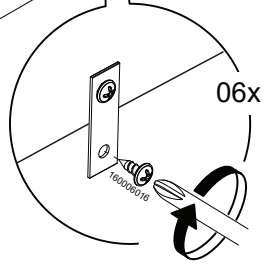
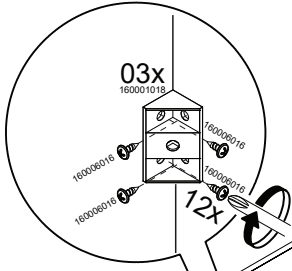
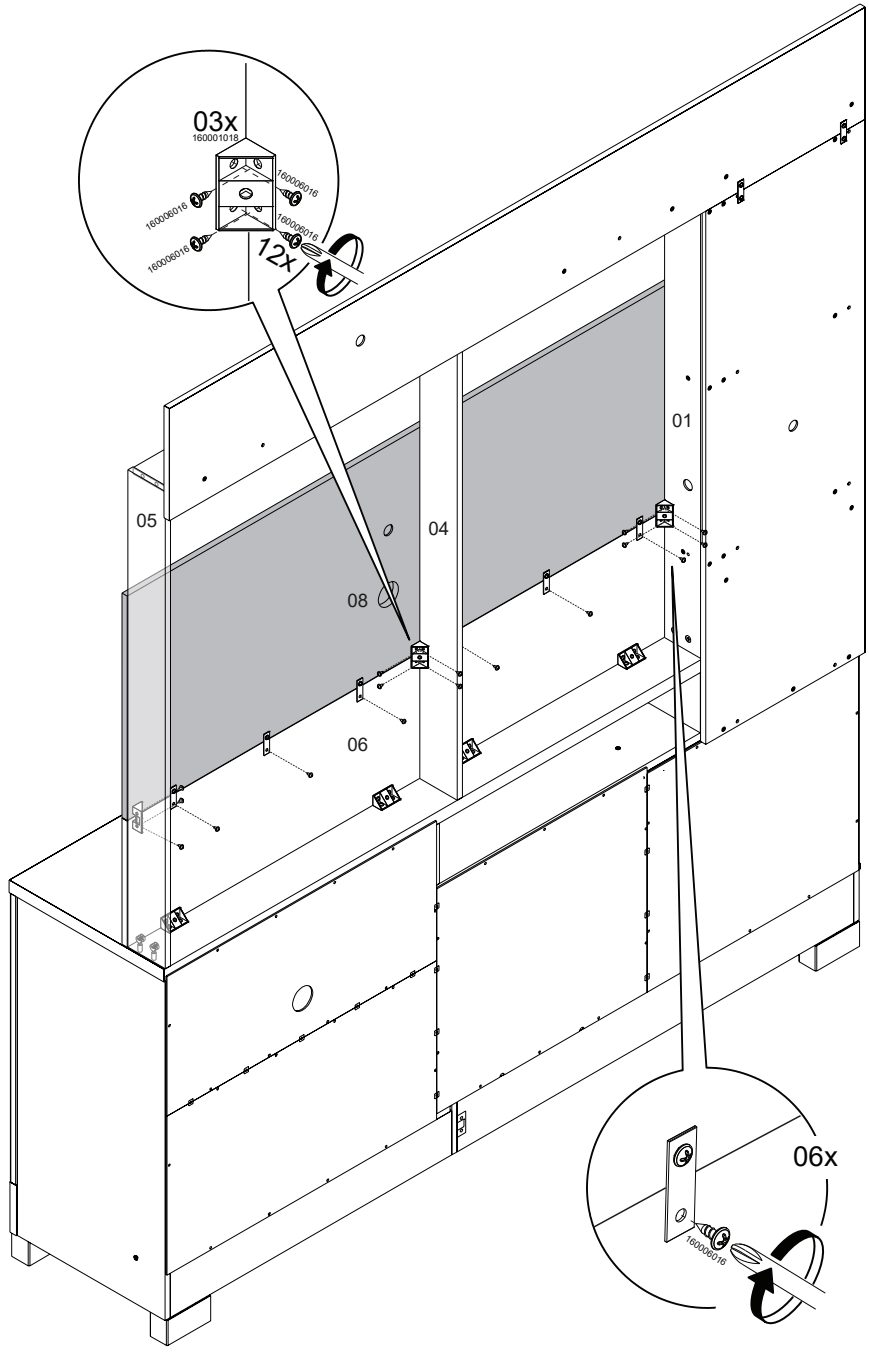
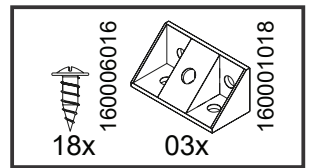

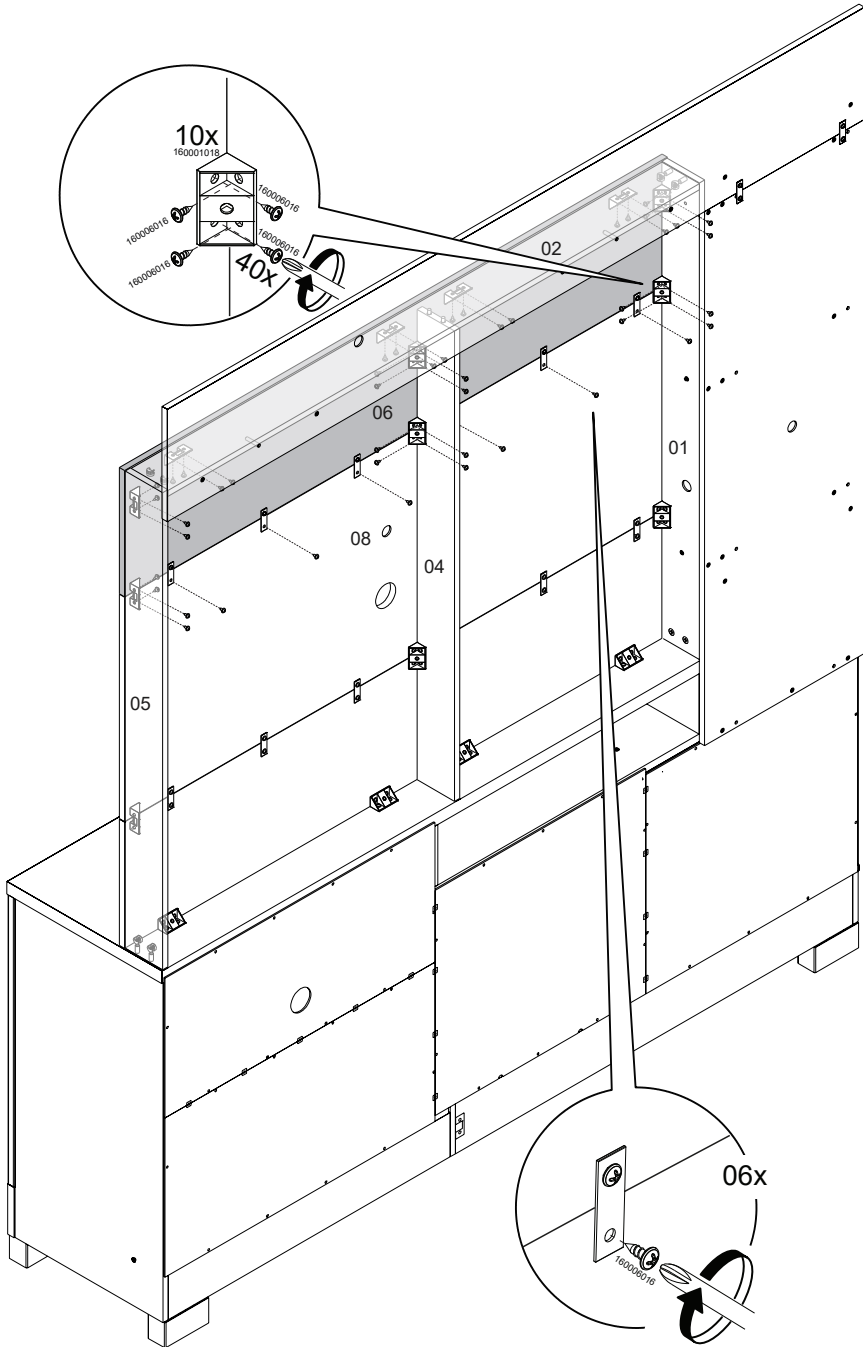
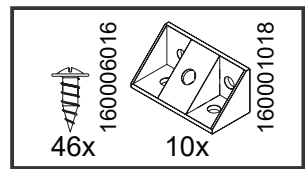

# 43

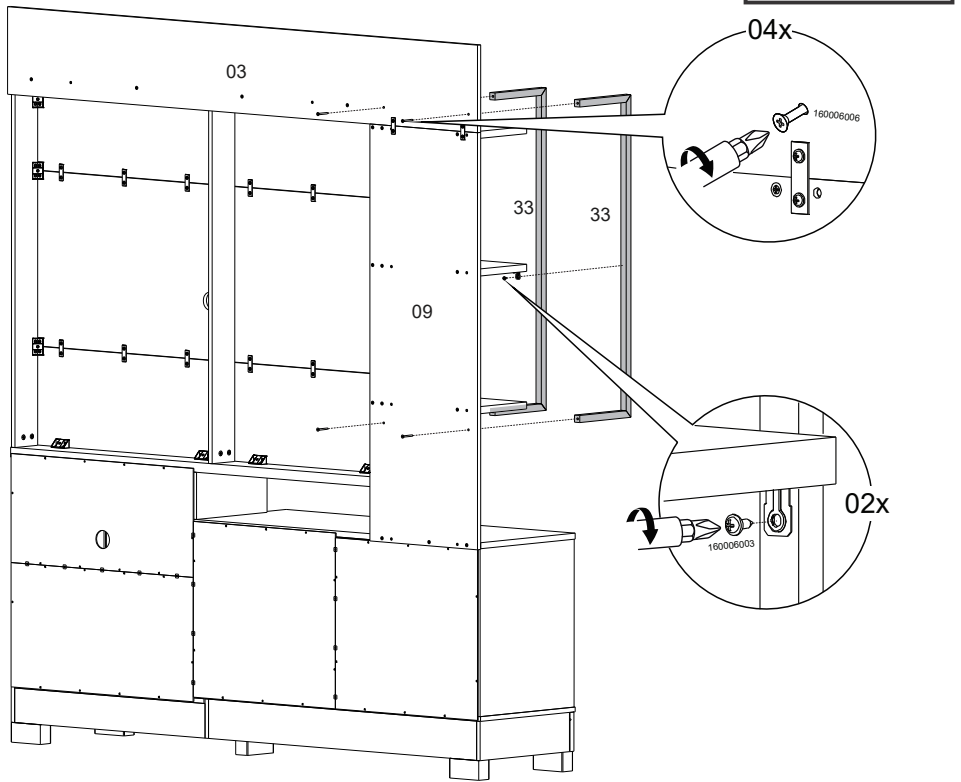

# 44

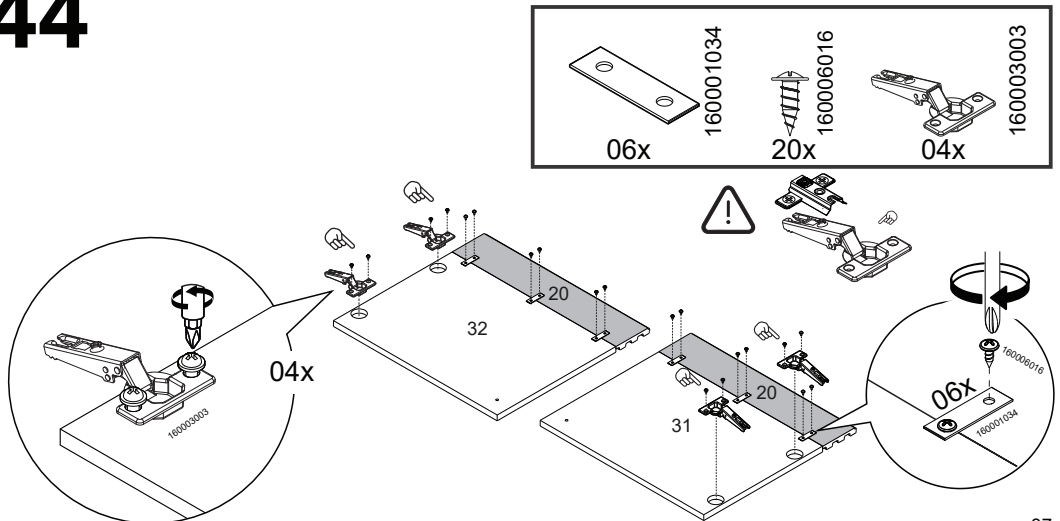

# 45

- 01x 160002005
- 02x 160006020
- 02x 160006022
- 02x 160005056
- 02x 160005055
- 08x 160006016
- 04x 160003003

