

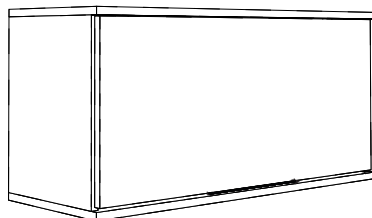

mxmóveis

Rodovia SC-492 - Km 10 - B. Industrial
89905-000 - Bandeirante - SC
Fone: (49) 3622-4549
e-mail: mxmoveis@mxmoveis.com.br



Ref. ATO02

Aéreo 800 Basc
Armario 800
Cozinha/Cocina
Toscana

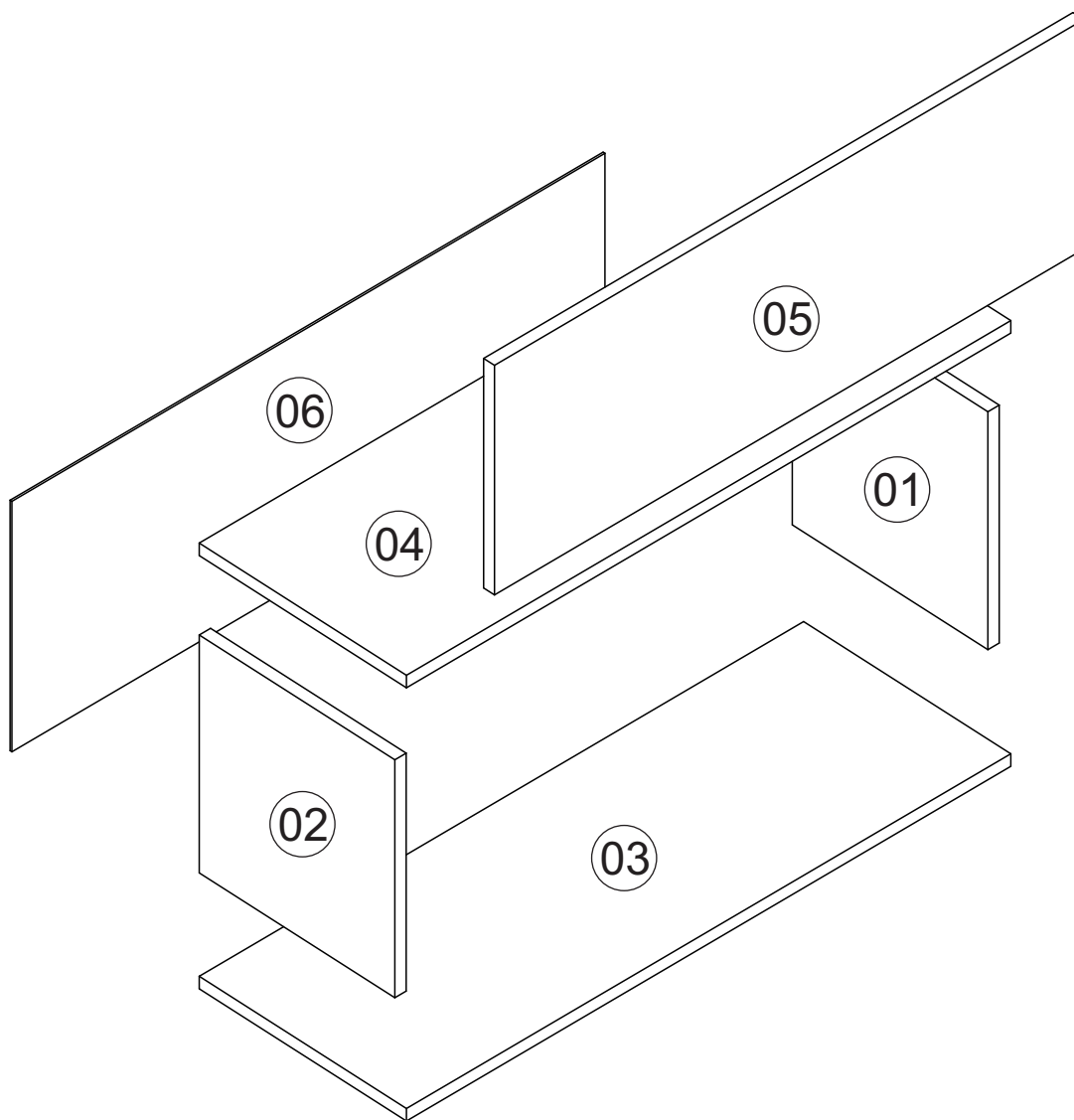

Nº	CÓDIGO ASSISTÊNCIA	NOME DA PEÇA/DESCRIPCIÓN PIEZAS	MEDIDAS (mm)	QTD.	CÓDIGO DAS PEÇAS/ CÓDIGO PIEZAS
					FREIJÓ/FREIJÓ
01	ATO02.17.01	Lateral externa direita/Lateral derecha	340x270x15	01	209897
02	ATO02.18.01	Lateral externa esquerda/Lateral izquierda	340x270x15	01	209898
03	ATO02.01.01	Base inferior/Base inferior	800x290x15	01	208663
04	ATO02.05.01	Base superior/Base superior	800x290x15	01	208664
05	ATO02.25.01	Porta/Puerta	780x332x15	01	209889
06	ATO02.13.01	Forro/Revés	790x360x2.5	01	209899

Ferragens/Herrajes

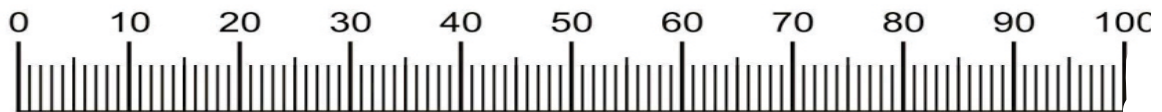
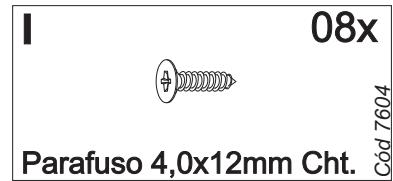
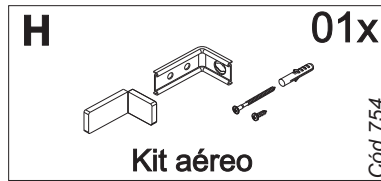
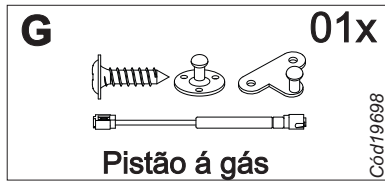
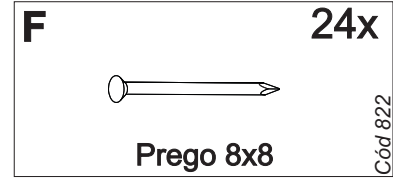
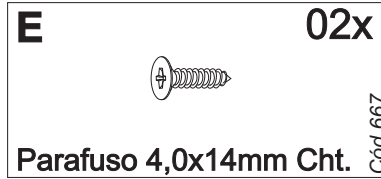
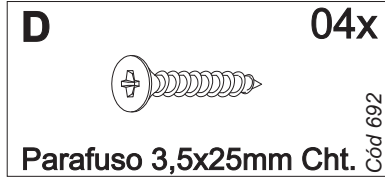
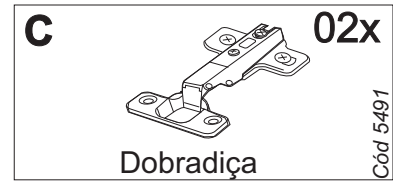
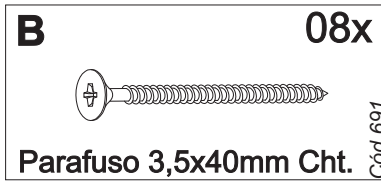
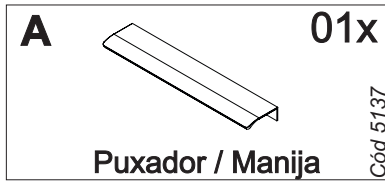

Medidas em mm

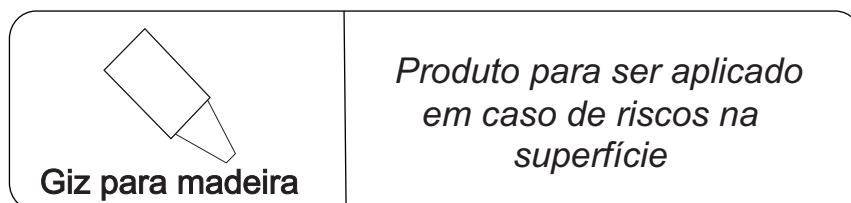
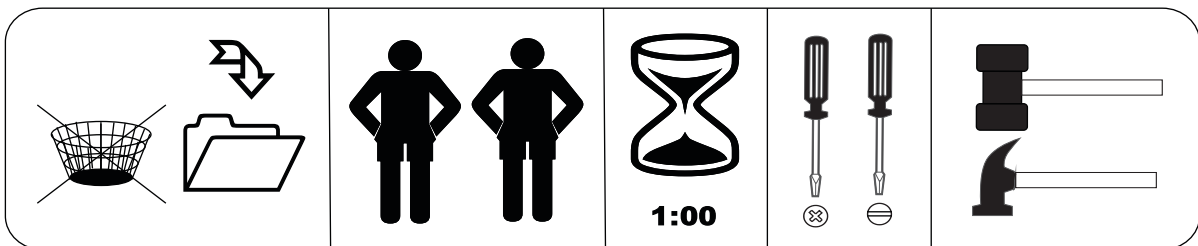

01 → Montagem/Montaje

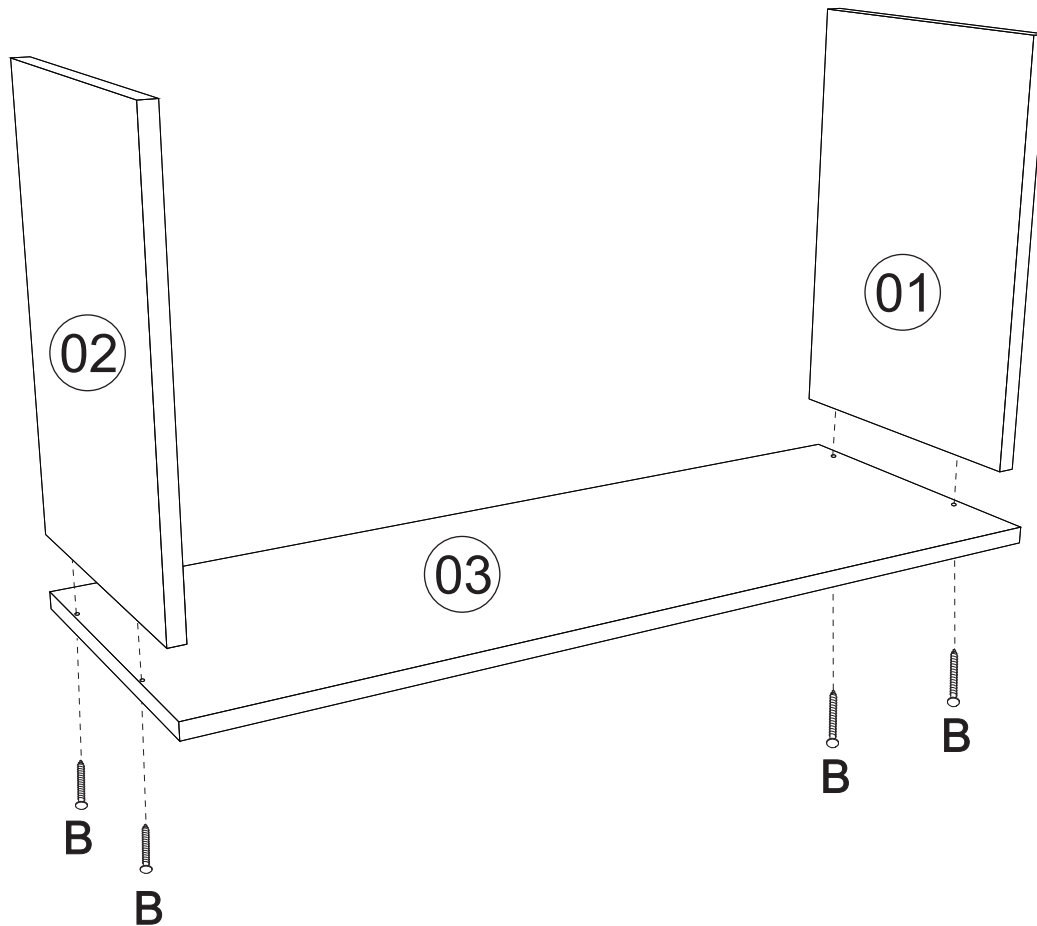

02 → Montagem/Montaje

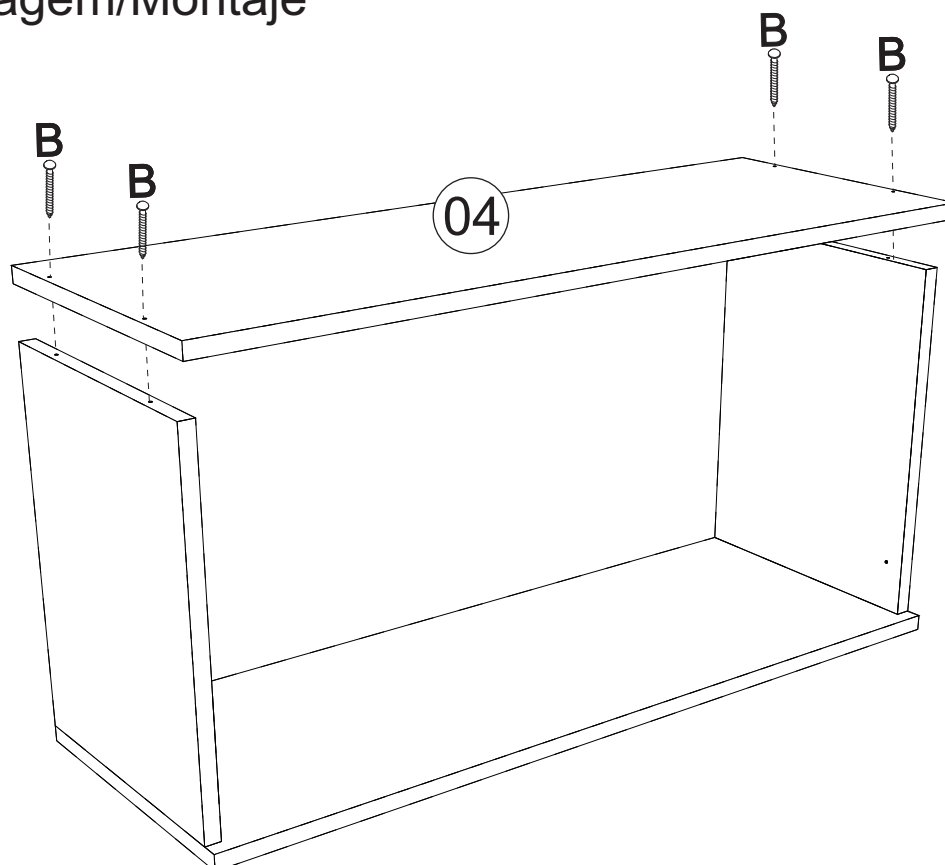

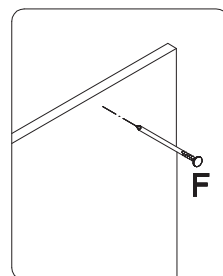
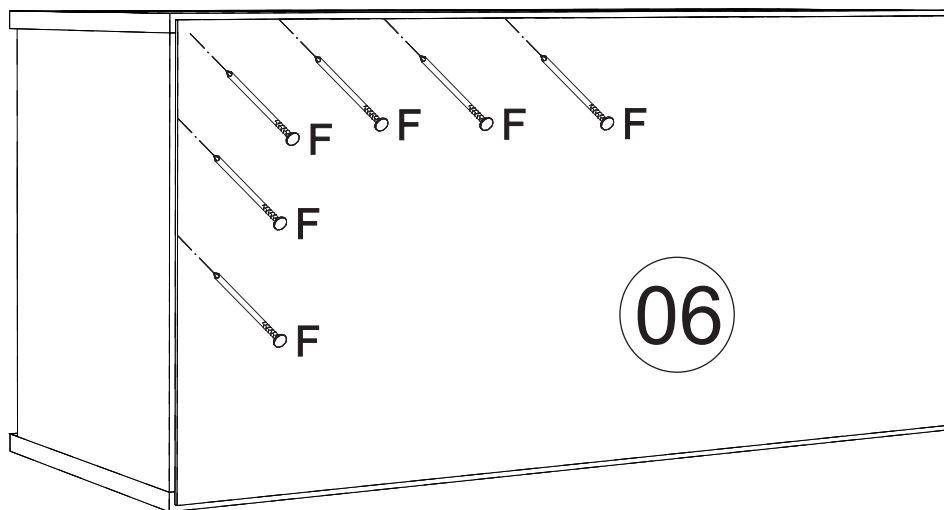
03**Montagem/Montaje**

*Colocar um prego (F)
a cada 100mm

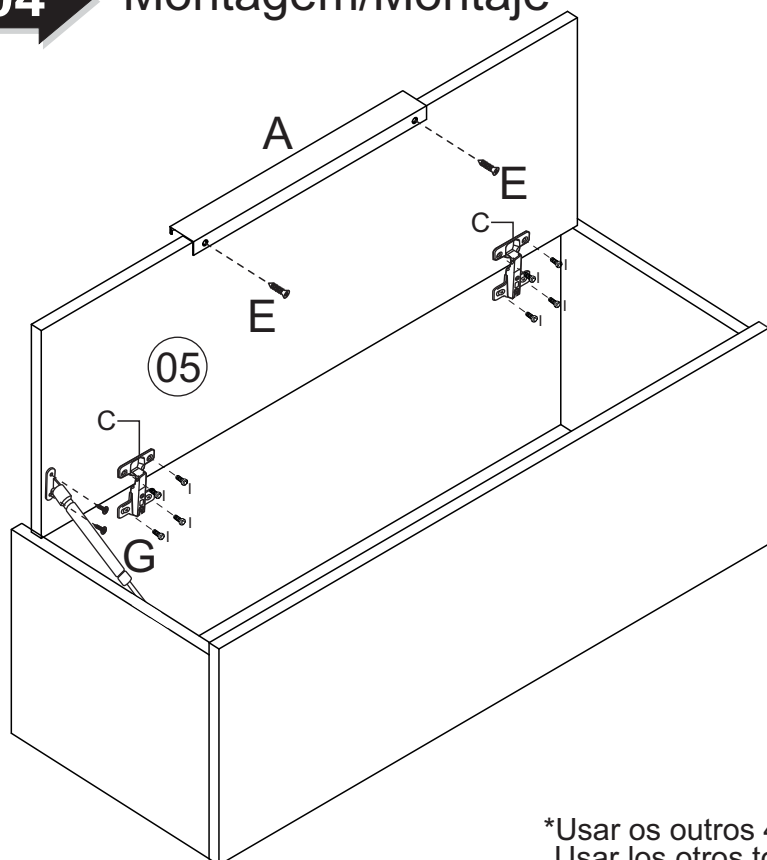
04**Montagem/Montaje**

Fixação na parede
Fijación en la pared

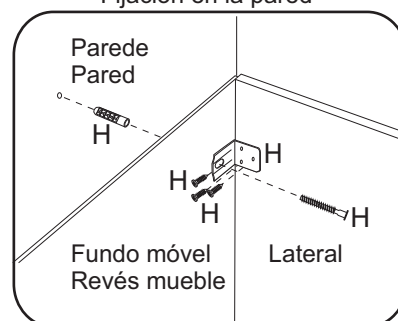

*Fixar a cantoneira na parte interna do móvel.
Fijar la pieza «H» en el interior del mueble.

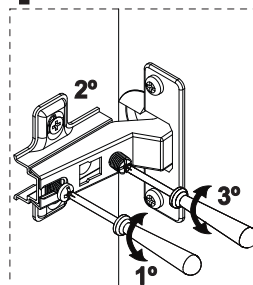
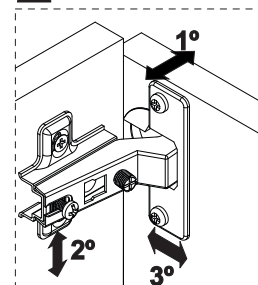
1º**2º**

*Usar os outros 4 parafusos (D) para unir este módulo a outro.
Usar los otros tornillos (D) para unirse este modulo a otro.



Rodovia SC-492 - Km 10 - B. Industrial
89905-000 - Bandeirante - SC
Fone: (49) 3622-4549
e-mail: mxmoveis@mxmoveis.com.br

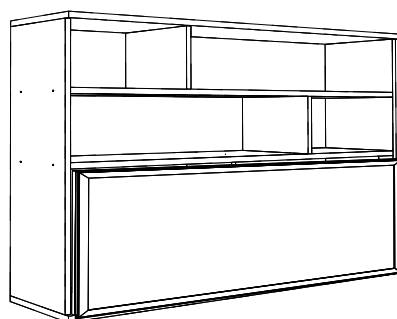

Ref. ATO03

Aéreo 1200
Armario 1200

Cozinha/Cocina
TOSCANA

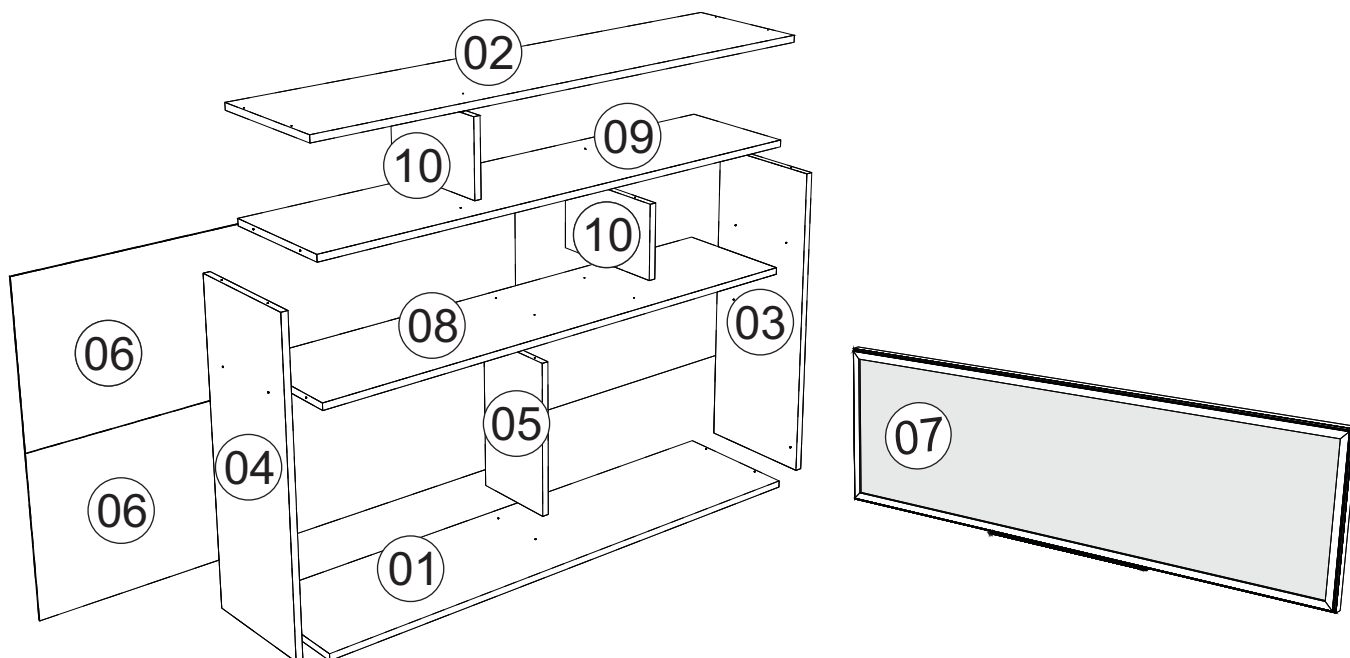

Nº	Código	NOME DA PEÇA/DESCRIPCIÓN PIEZAS	MEDIDAS (mm)	QTD.	CÓDIGO DAS PEÇAS/ CÓDIGO PIEZAS
					FREIJÓ/FREIJÓ
01	ATO03.01.01	Base inferior/Base inferior	1200x290x15	01	208697
02	ATO03.05.01	Base superior/Base superior	1200x290x15	01	208698
03	ATO03.17.01	Lateral externa direita/Lateral derecha	710x270x15	01	209912
04	ATO03.18.01	Lateral externa esquerda/Lateral izquierda	710x270x15	01	209913
05	ATO03.19.00	Lateral interna/Divisoria	343x195x15	01	208693
06	ATO03.13.01	Forro/Revés	1190x361x2.5	02	209915
07	5268	Porta/Puerta	1180x348x20	01	
08	ATO03.02.01	Base interna/Base pequena	1170x270x15	01	208696
09	ATO03.02.00	Base interna/Base pequena	1170x270x15	01	208692
10	ATO03.19.02	Lateral interna inf. /Divisoria	267x168x15	02	209914

Ferragens/Herrajes

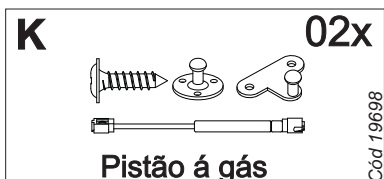
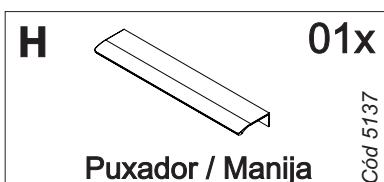
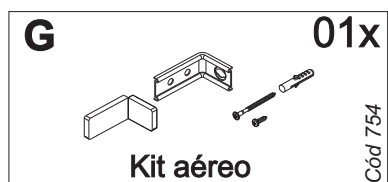
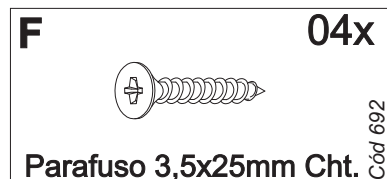
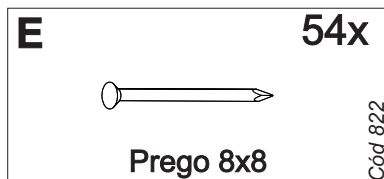
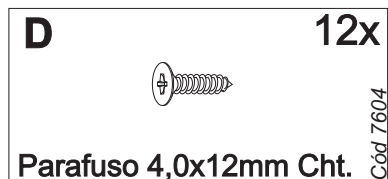
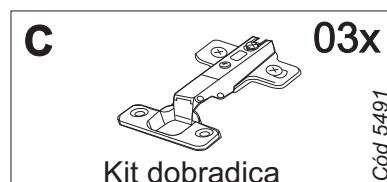
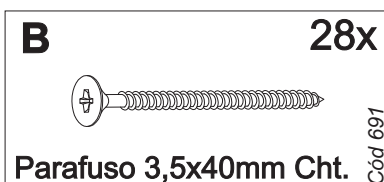
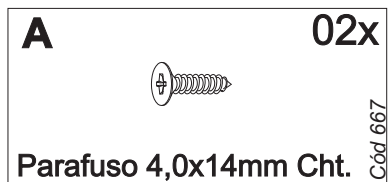

*Usar os parafusos (F) para unir este módulo a outro.
Usar los tornillos (F) para unirse este módulo a otro.



Medidas em mm

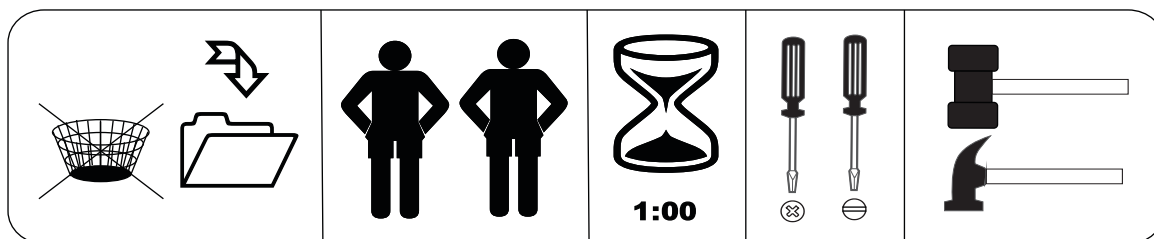

Produto para ser aplicado
em caso de riscos na
superfície

01 → Montagem/Montaje

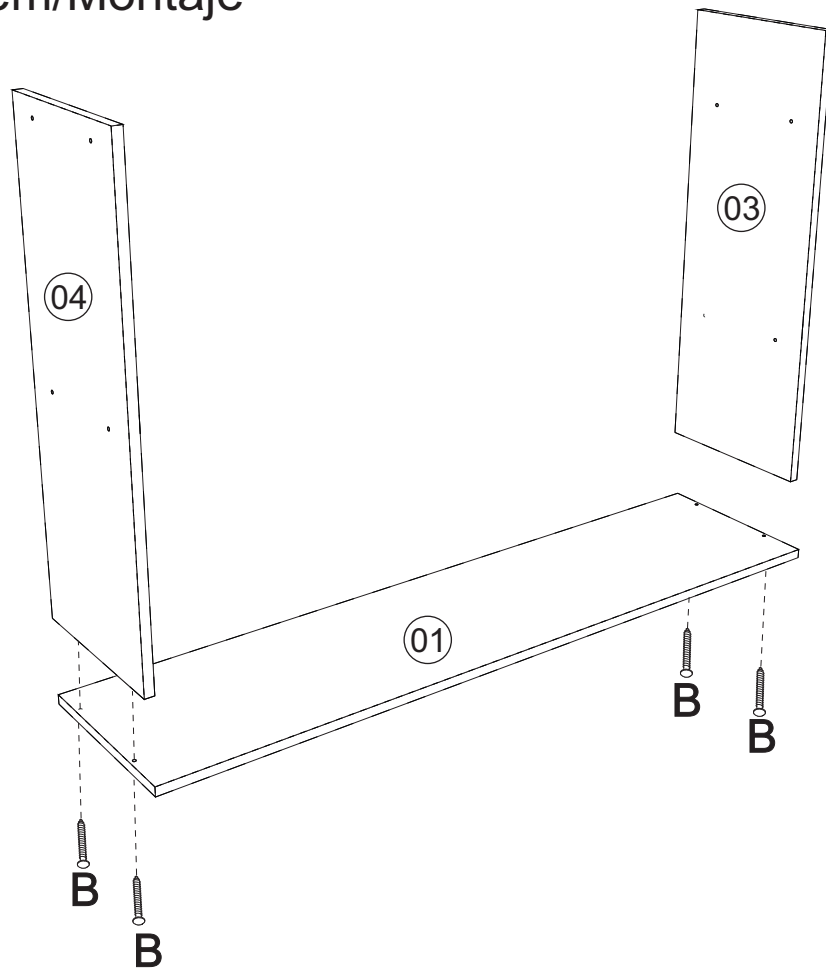

02 → Montagem/Montaje

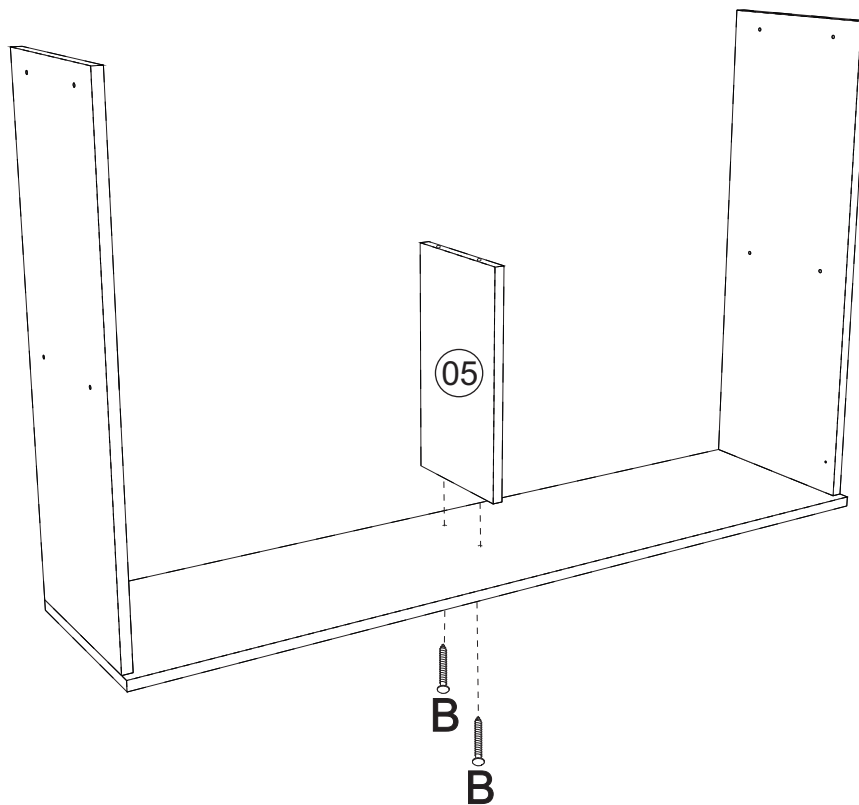

03 Montagem/Montaje

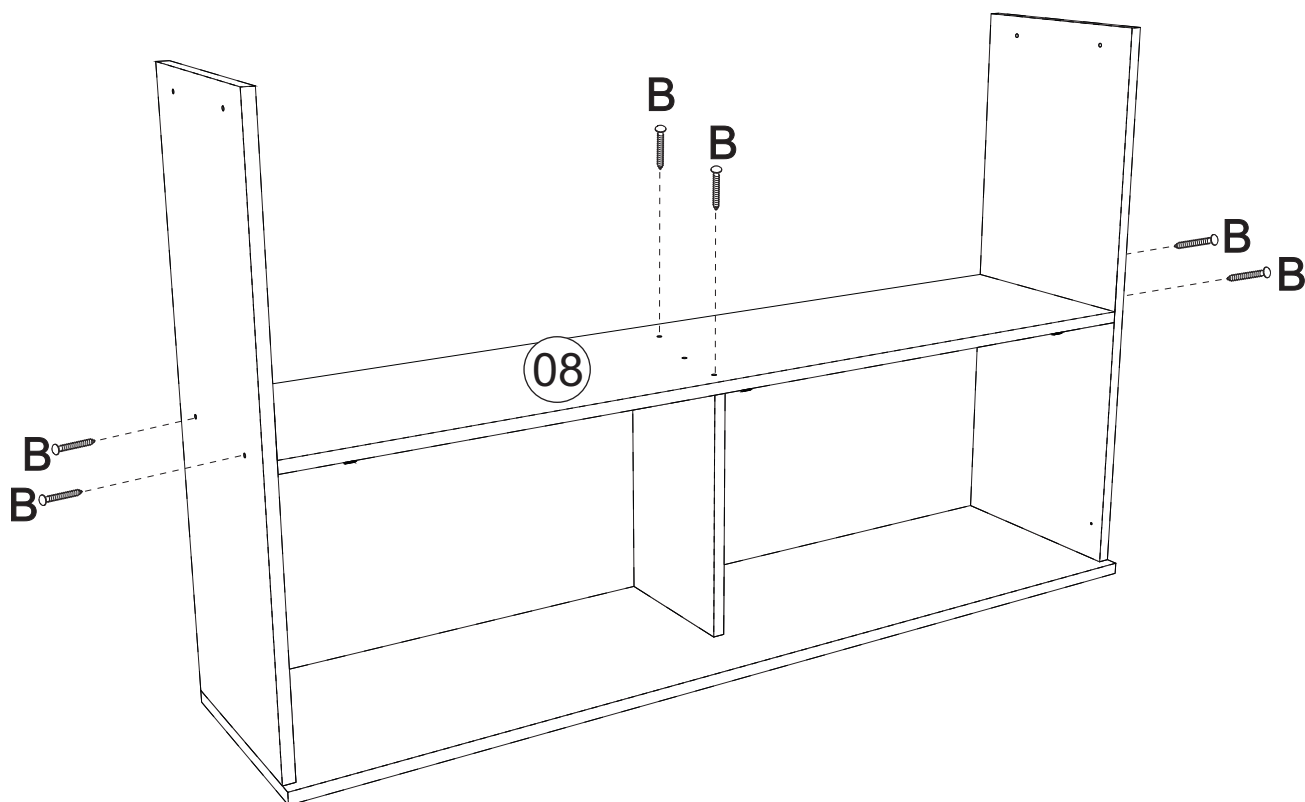

04 Montagem/Montaje

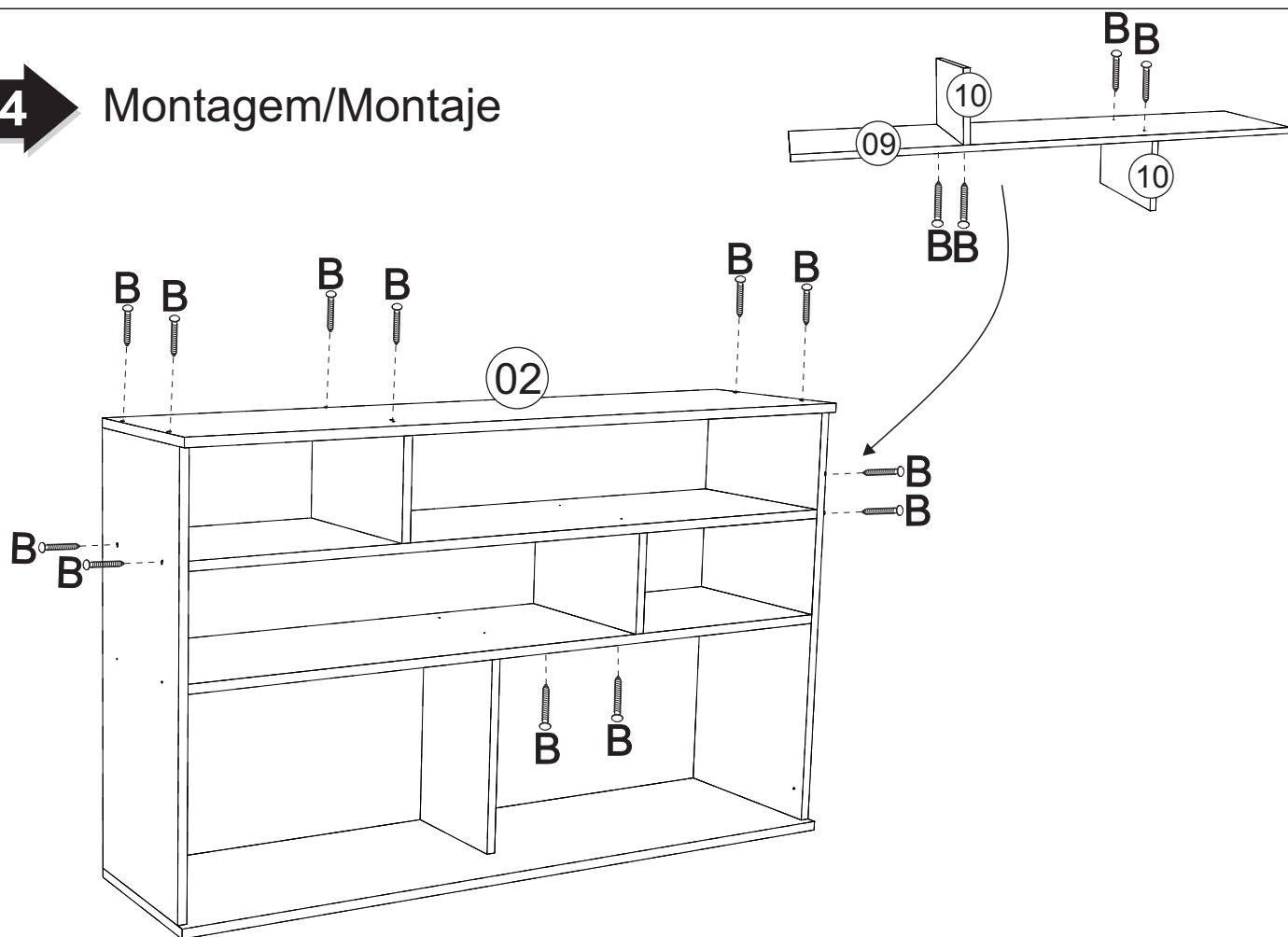

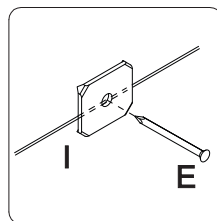
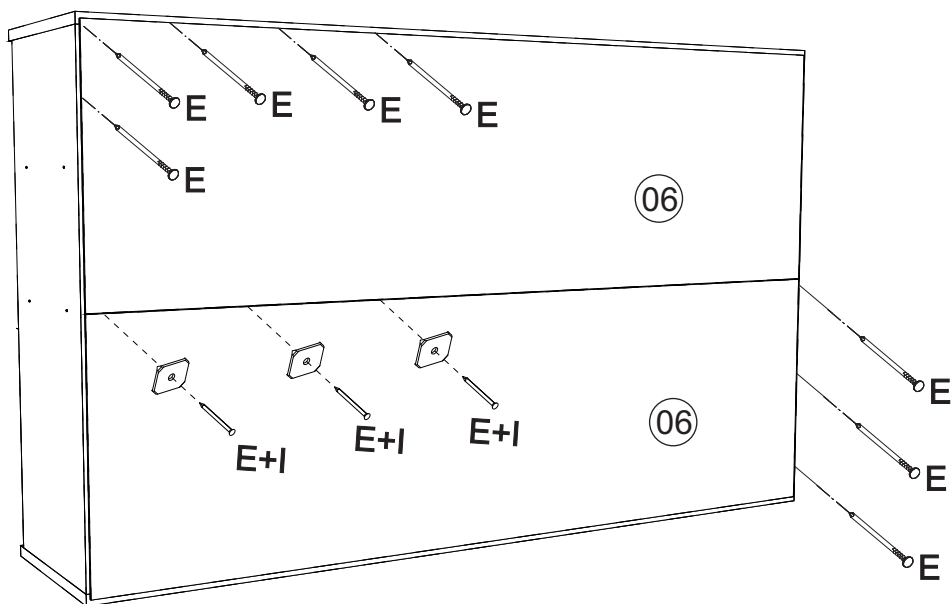
06**Montagem/Montaje**

*Colocar o prego (E) e a junção (I) a cada 100mm

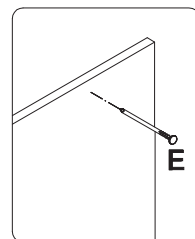

*Colocar um prego (E) a cada 100mm

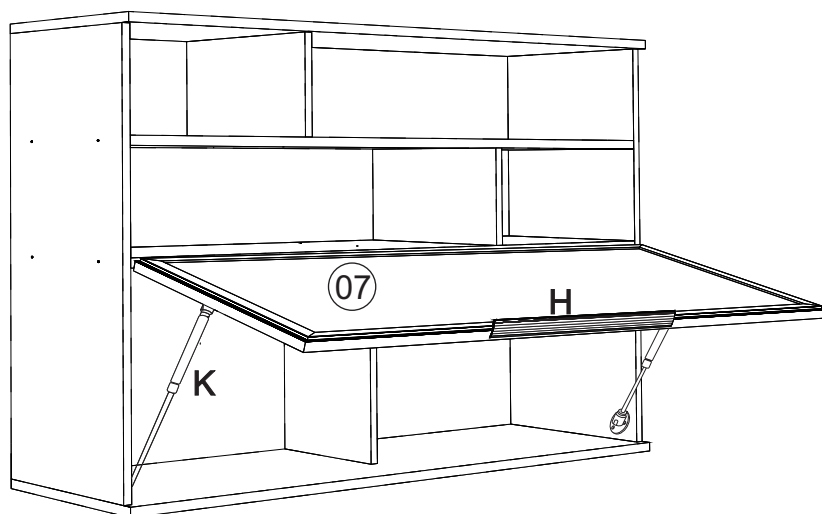
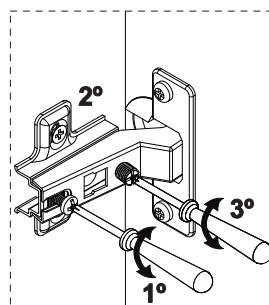
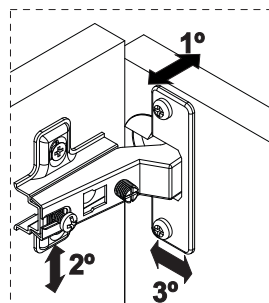
07**Montagem/Montaje****1º****2º**

Fixação na parede
Fijación en la pared

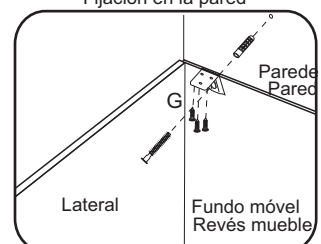

*Fixar a cantoneira na parte interna do móvel.
Fijar la pieza «G» en el interior del mueble.

Limpeza/Limpieza

- ✍ Use um pano levemente umedecido com água, seguido de pano seco.
- ✍ *Use solamente un paño húmedo con agua y después un paño seco.*
- ✍ Nunca utilize produtos químicos ou abrasivos.
- ✍ *No utilice productos quimicos o abrasivos.*



Rodovia SC-492 - Km 10 - B. Industrial
89905-000 - Bandeirante - SC
Fone: (49) 3622-4549
e-mail: mxmoveis@mxmoveis.com.br

Ref ATO04

Aéreo Canto
Armario Esquinero
Cozinha/Cocina
TOSCANA

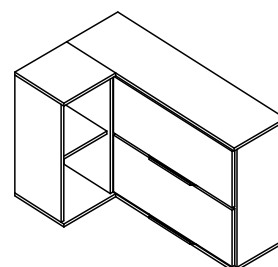
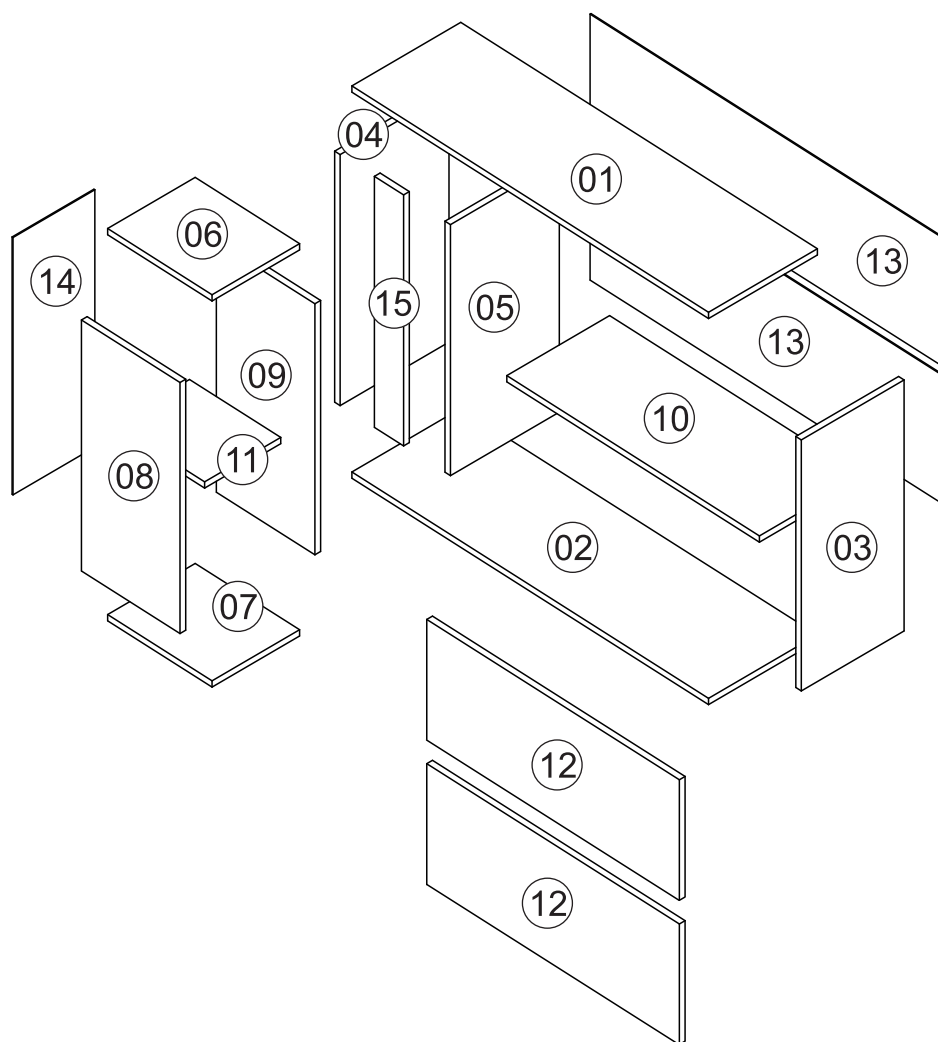

Direito/Derecho

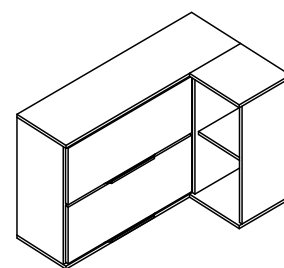

Esquerdo/Izquierdo

Nº	CÓDIGO ASSISTÊNCIA	NOME DA PEÇA/DESCRIPCIÓN PIEZAS	MEDIDAS (mm)	QTD.	CÓDIGO DAS PEÇAS	
					FRELÓ/FRELÓ	FRELÓ/FRELÓ
01	ATO04.05.00	Base superior/Base superior	977x290x15	01	208739	
02	ATO04.01.00	Base inferior/Base inferior	977x290x15	01	208738	
03	ATO04.17.01	Lateral externa direita/Lateral derecha	710x270x15	01	209936	
04	ATO04.19.00	Lateral externa esquerda	710x290x15	01	210871	
05	ATO04.19.05	Lateral interna direita/Lateral derecha	710x290x15	01	209940	
06	ATO04.05.01	Base superior/Base superior	290x286x15	01	208744	
07	ATO04.01.01	Base inferior/Base inferior	290x286x15	01	208743	
08	ATO04.18.01	Lateral externa esquerda nicho	710x270x15	01	209937	
09	ATO04.19.06	Lateral externa esquerda	710x270x15	01	209943	
10	ATO04.02.00	Base interna	691x270x15	01	208740	
11	ATO04.02.02	Base interna	267x556x15	01	209941	
12	ATO04.25.01	Porta/Puerta	692x347x15	02	209928	
13	ATO04.13.02	Forro maior/Revés mayor	967x361x2,5	02	209939	
14	ATO04.13.03	Forro adega/Revés	730x280x2,5	01	209942	
15	ATO04.06.01	Ripa batente/Travesaño	710x80x15	01	209938	

Ferragens/Herrajes

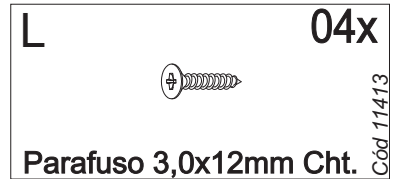
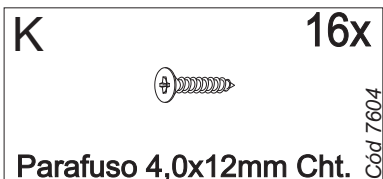
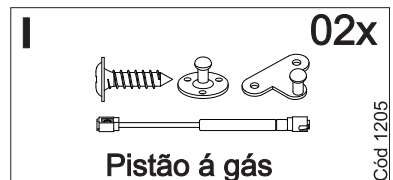
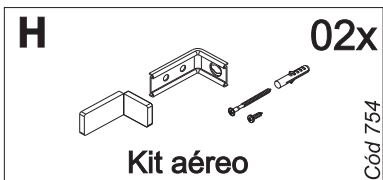
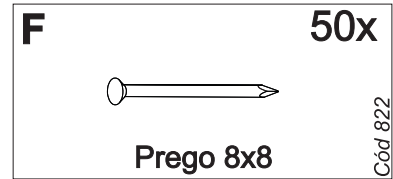
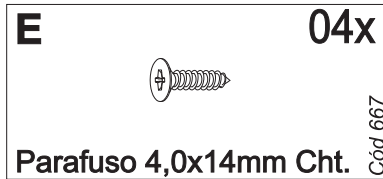
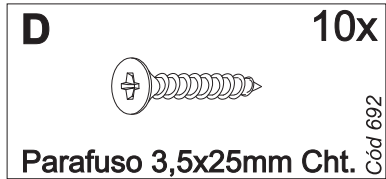
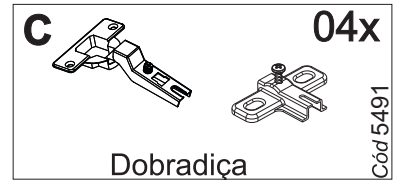
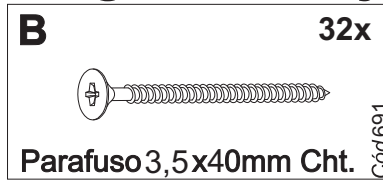
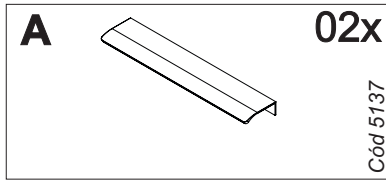

*Usar os parafusos (D) para unir este módulo a outro.
Usar los tornillos (D) para unirse este módulo a otro.

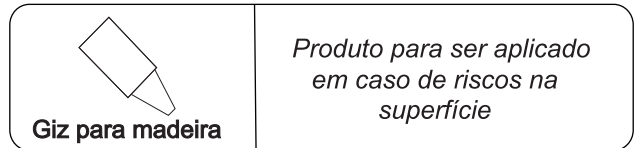
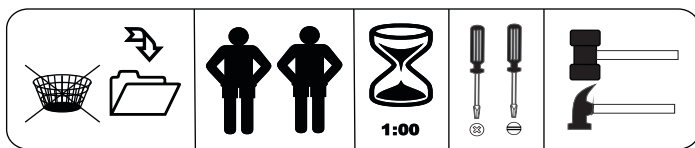

Pré-Montagem/Preparación Piezas

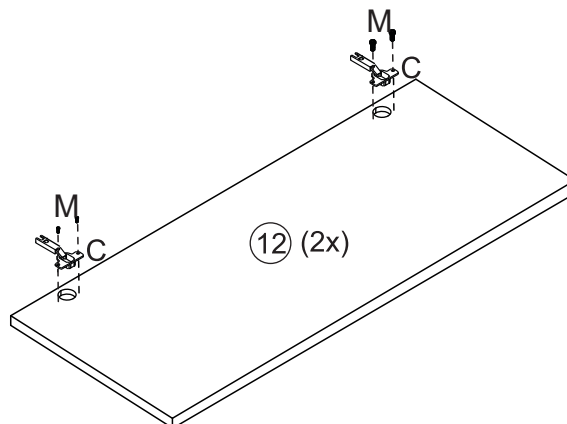

Montagem/Montaje

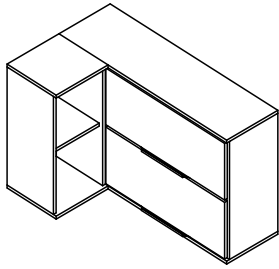

Direito/Derecho

01

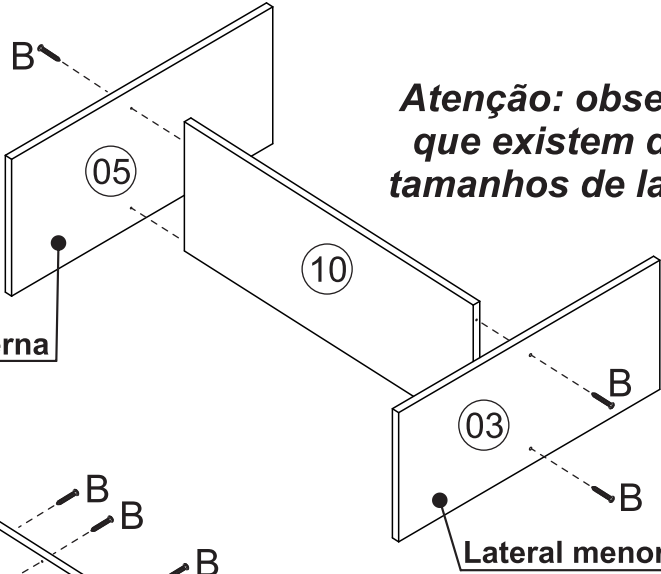

Atenção: observar que existem dois tamanhos de lateral

Lateral interna maior

Lateral menor

02

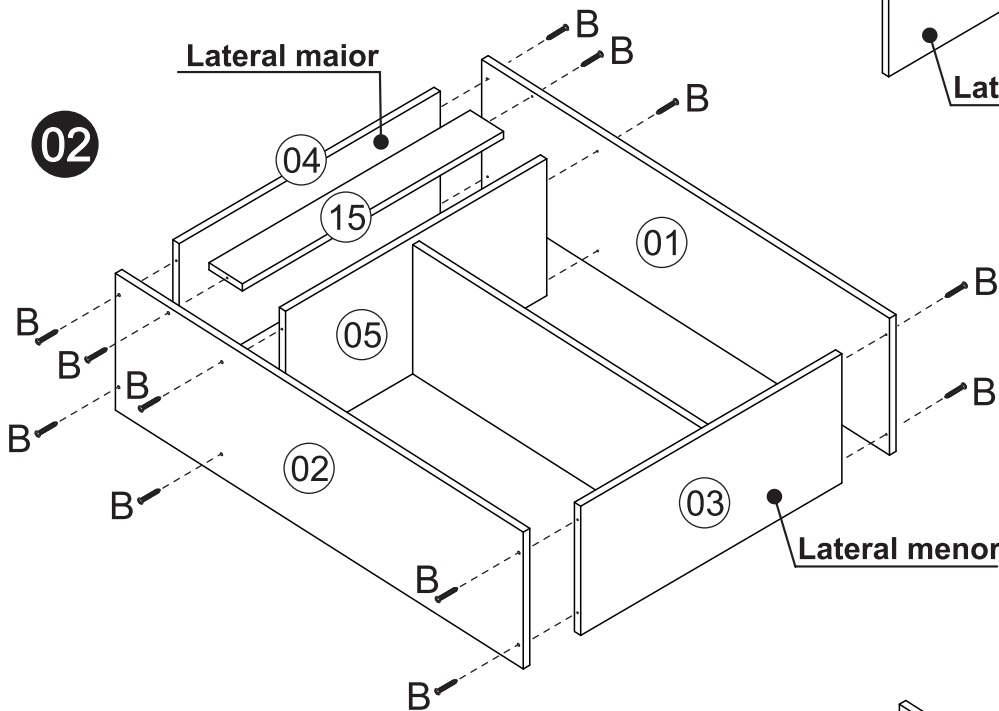

Lateral maior

Lateral menor

03

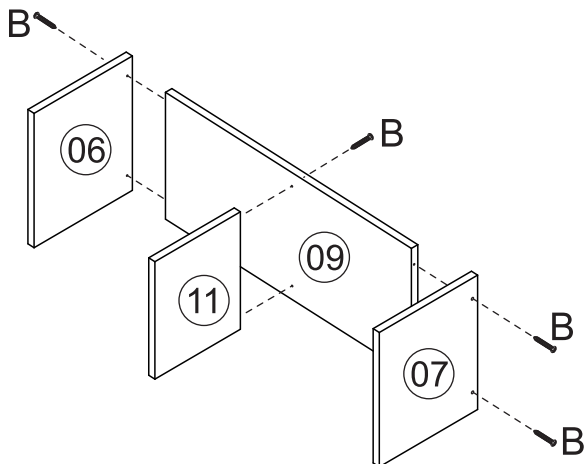

04

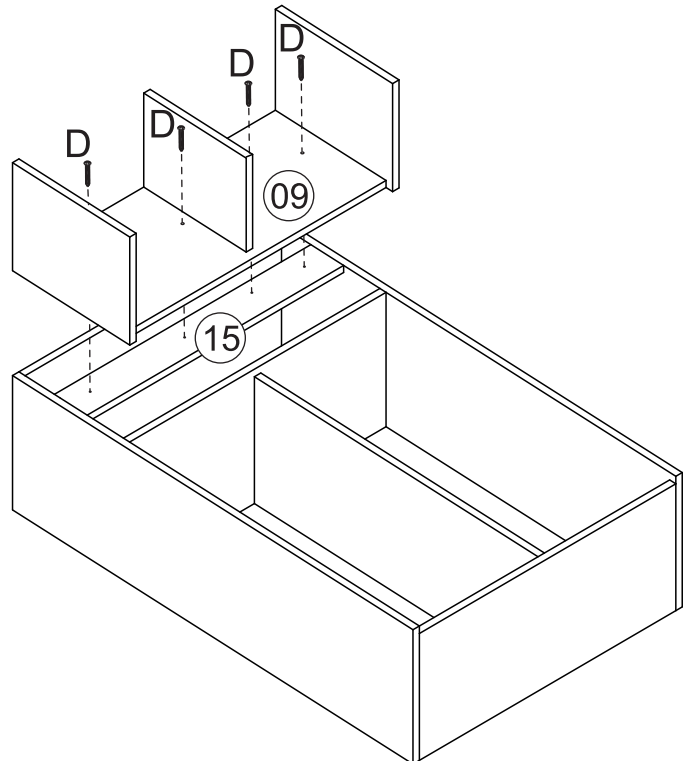

Montagem/Montaje

05

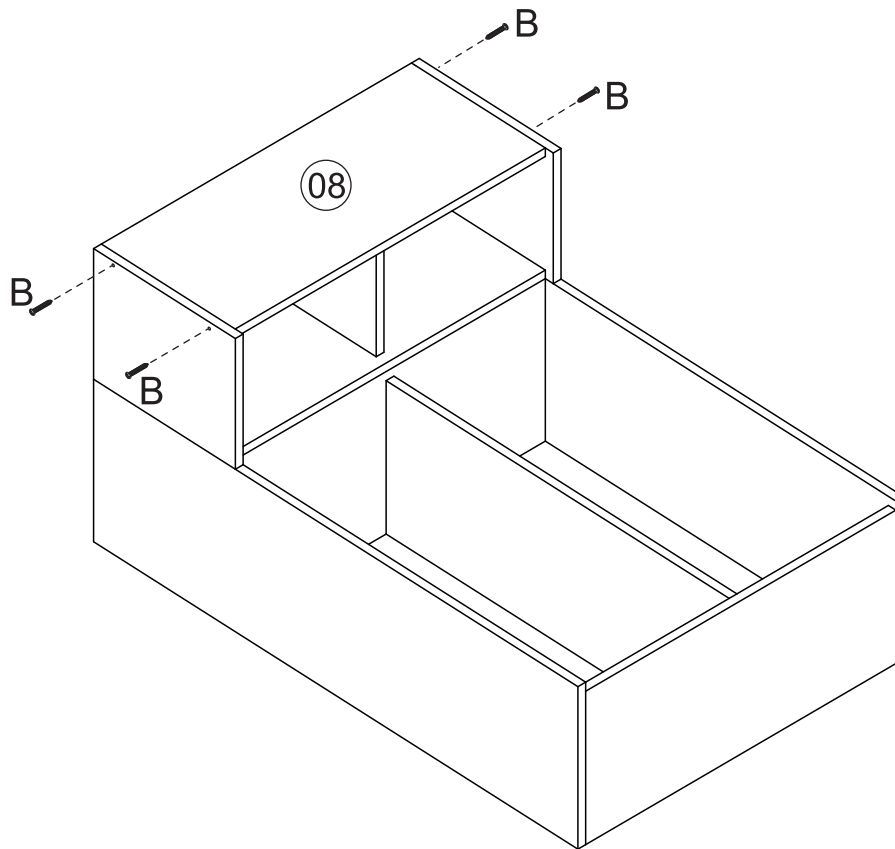

06

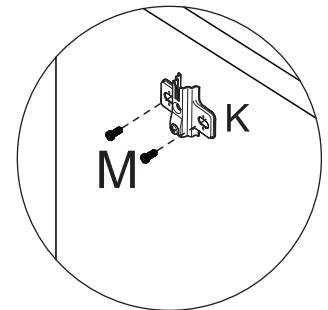
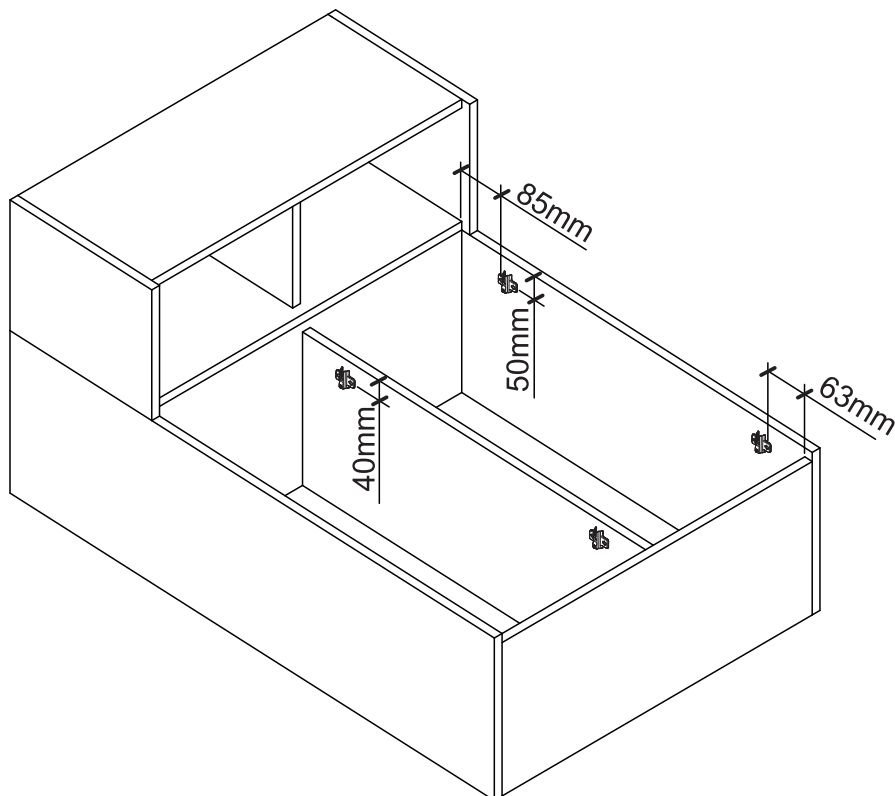

Atenção: observar medidas indicadas para fixação do calço

Montagem/Montaje

07

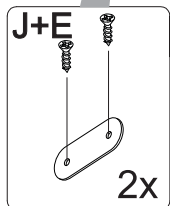
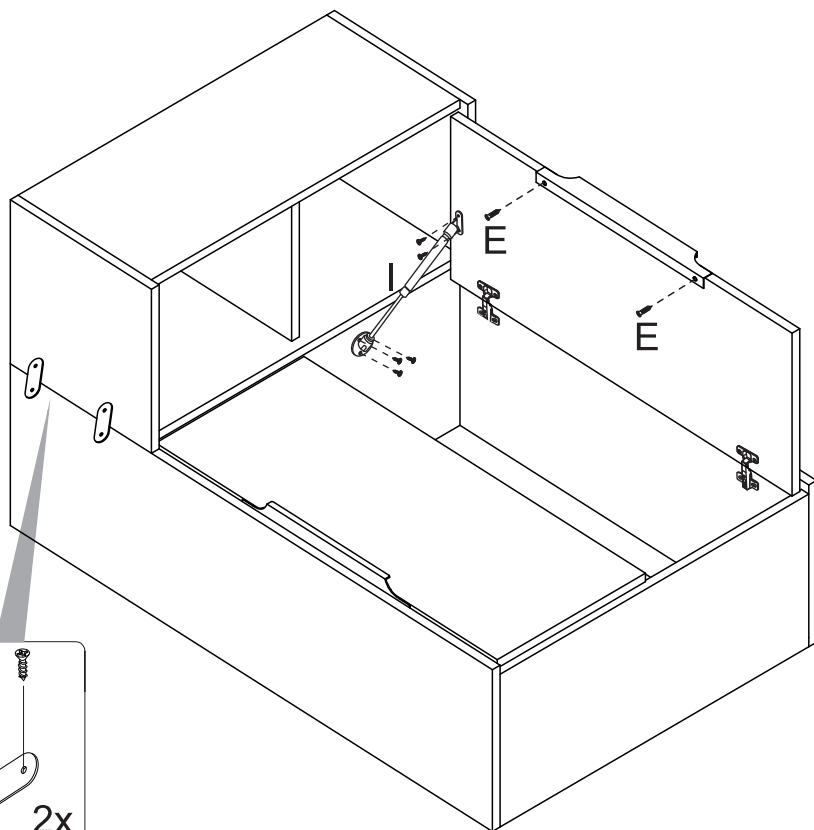

08

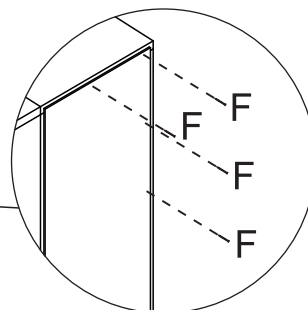

* Usar um prego (F) a cada 100mm

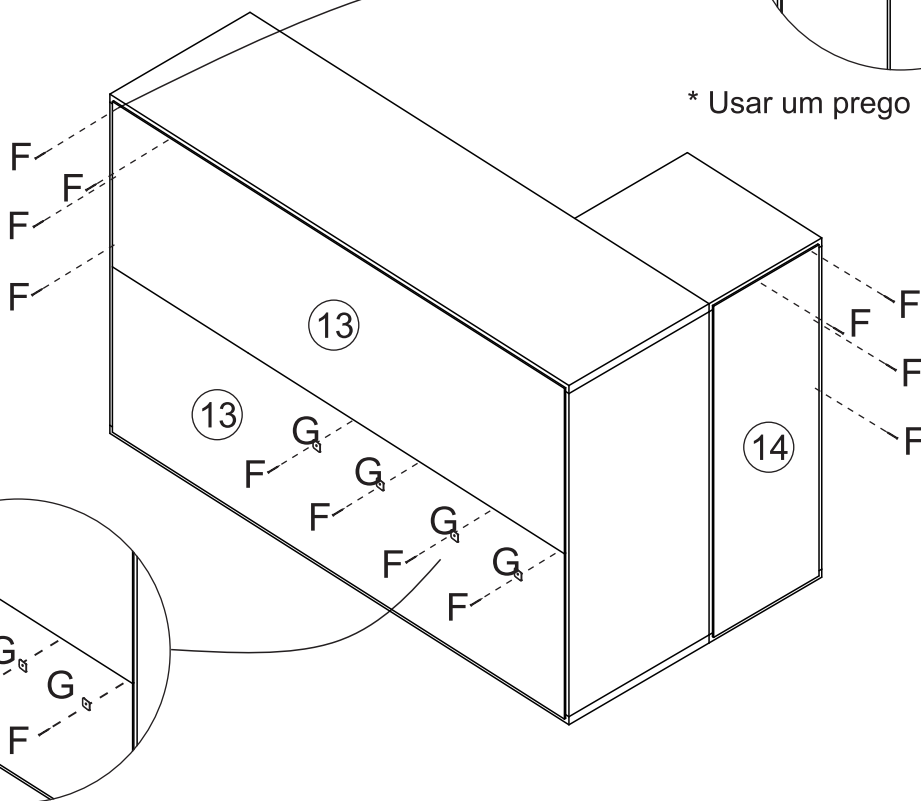

* Usar um prego (F) e um junção (G) a cada 100mm

Montagem/Montaje

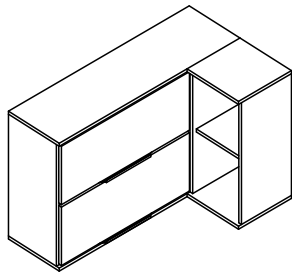

Esquerdo/Izquierdo

01

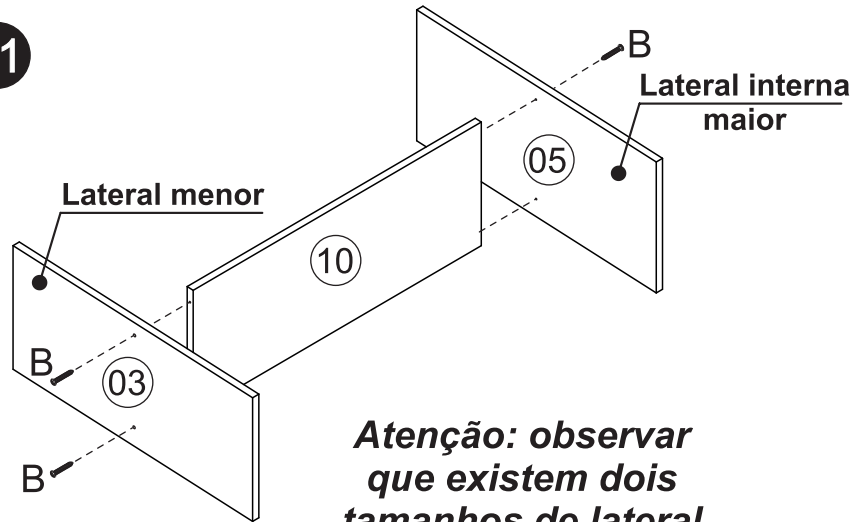

Atenção: observar que existem dois tamanhos de lateral

02

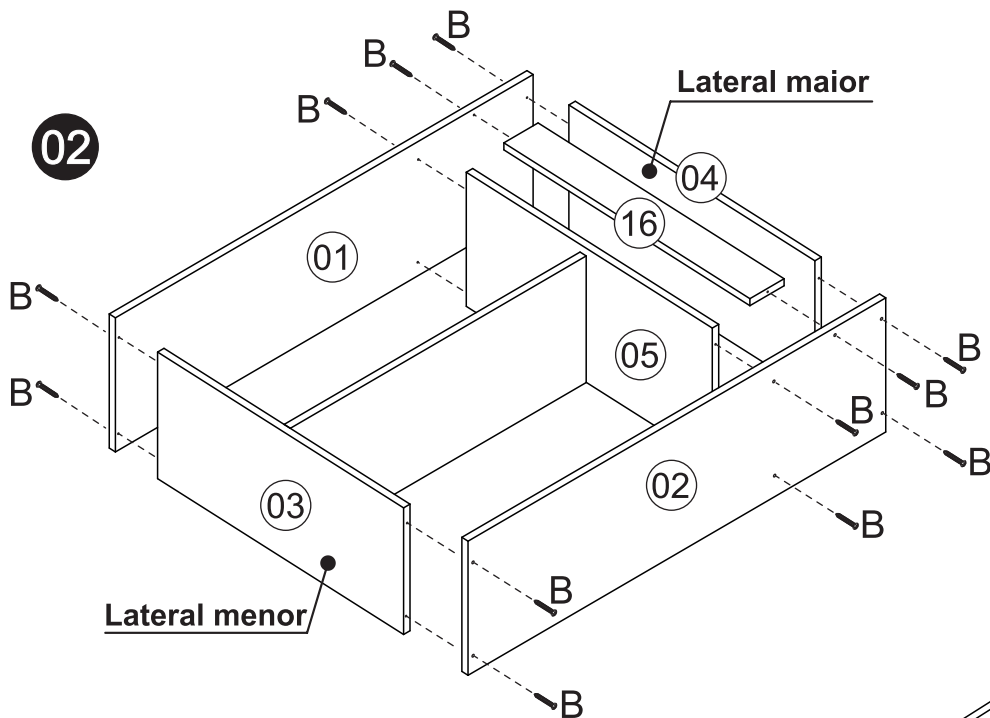

03

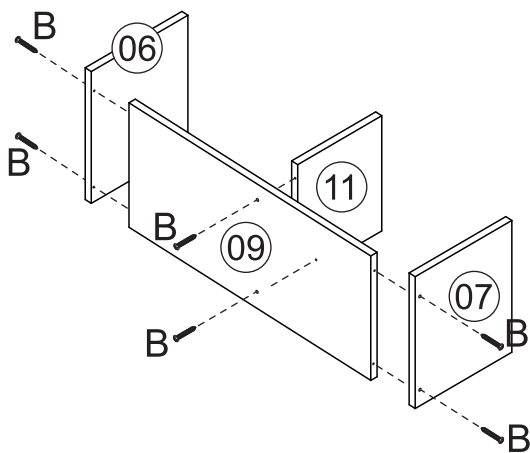

04

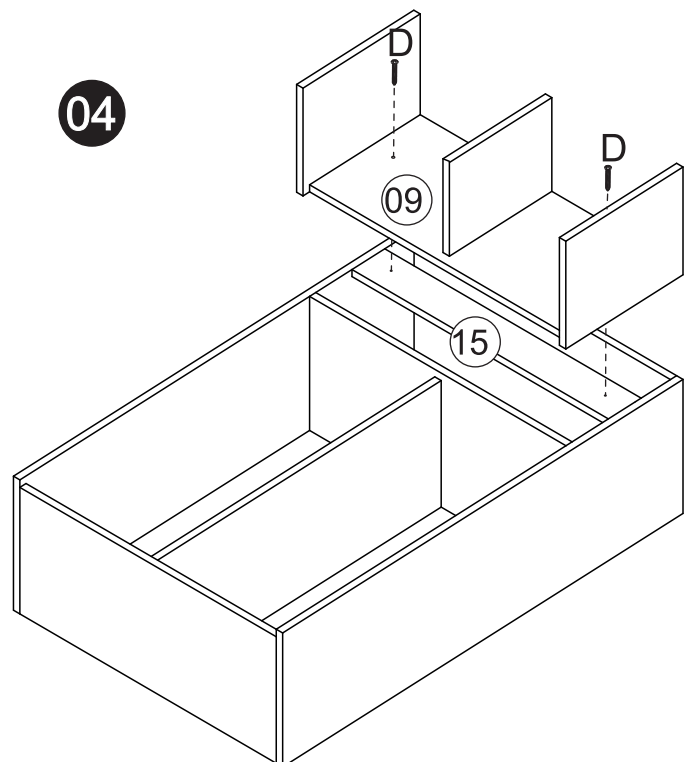

Montagem/Montaje

05

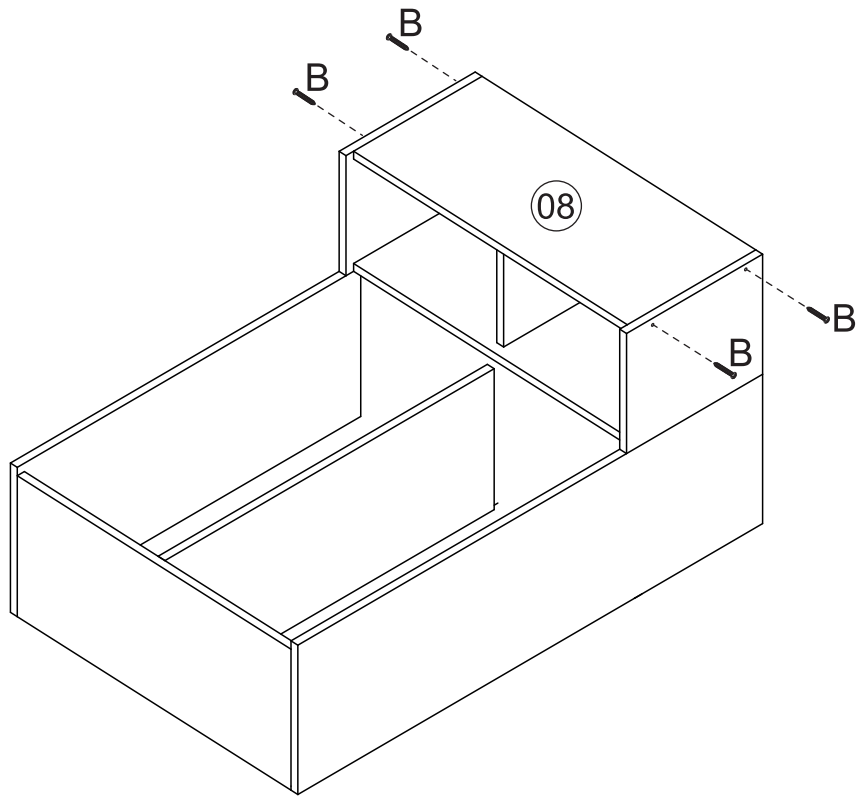

06

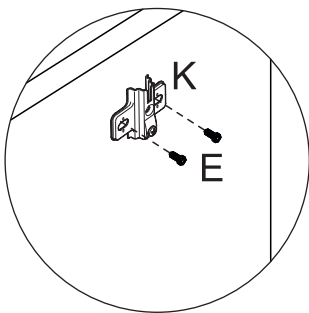

Atenção: observar medidas indicadas para fixação do calço

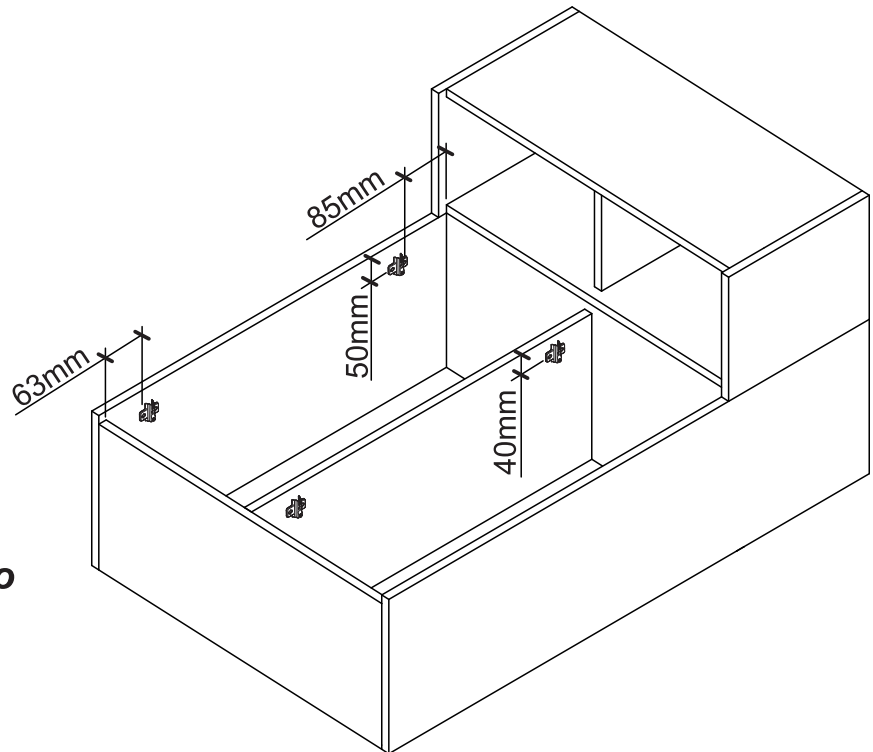

Montagem/Montaje

07

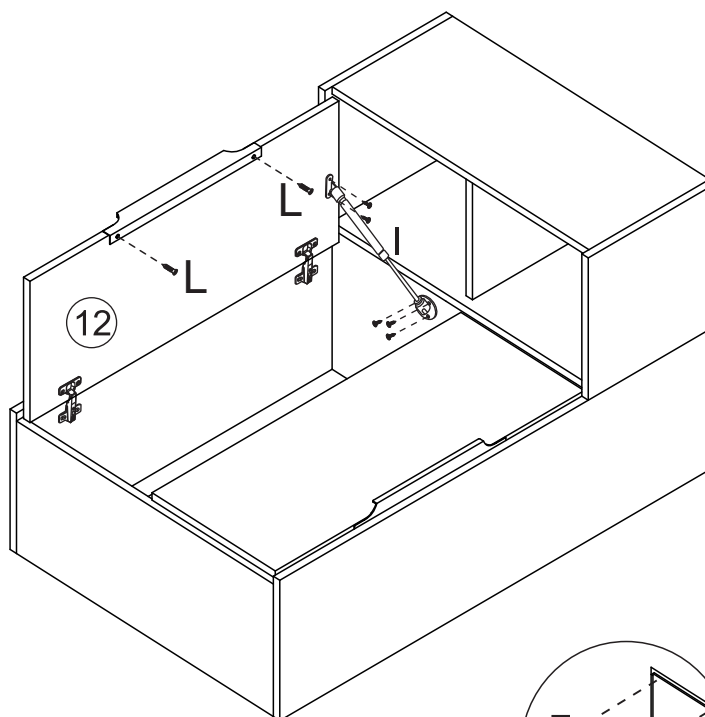
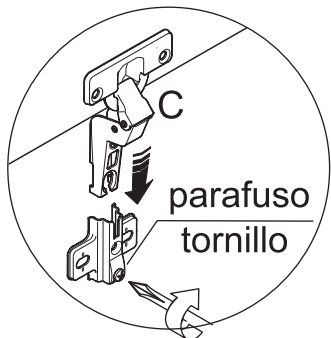

08

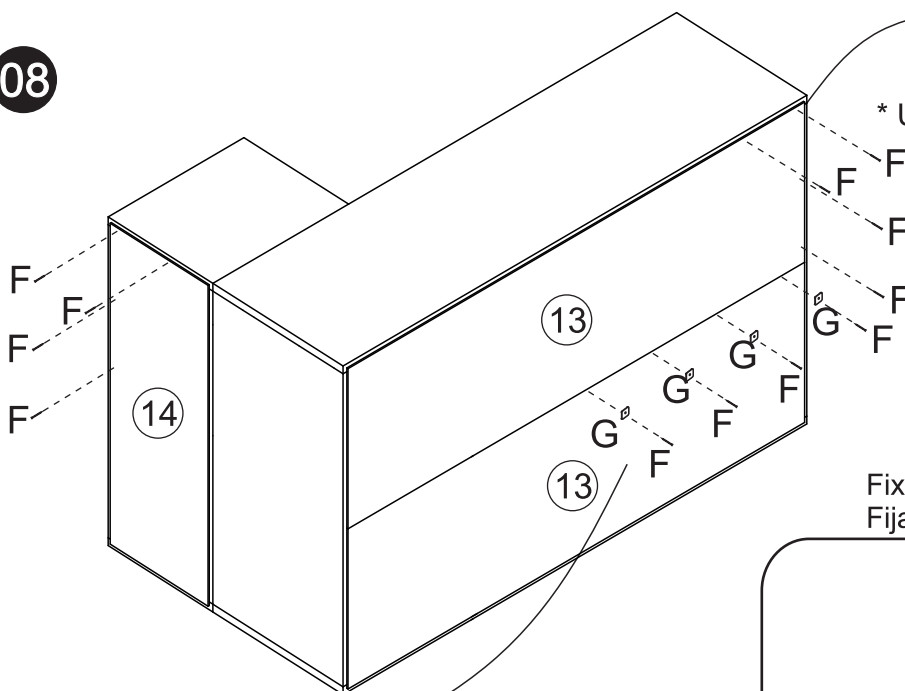

* Usar um prego (F) a cada 12mm

Fixação na parede
Fijación en la pared

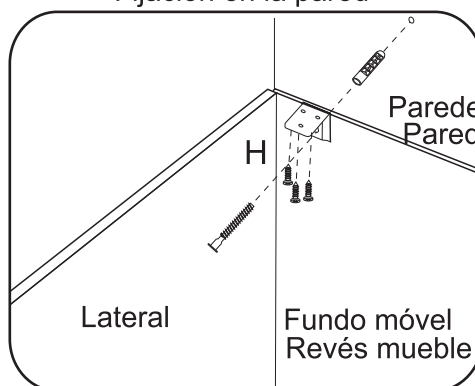

*Fixar a cantoneira na parte interna do móvel.
Fijar la pieza «H» en el interior del mueble.

*Usar os outros 4 parafusos (D) para unir este módulo a outro.
Usar los otros tornillos (D) para unirse este modulo a otro.

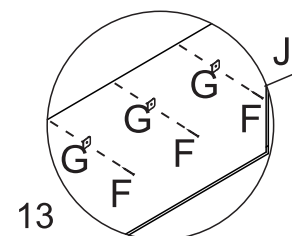

* Usar um prego (F) e uma junção (G) a cada 12mm

Limpeza/Limpieza

- ✘ Use um pano levemente umedecido com água, seguido de pano seco.
- ✘ Use solamente un paño húmedo con agua y después un paño seco.
- ✘ Nunca utilize produtos químicos ou abrasivos.
- ✘ No utilice productos químicos o abrasivos.



Rodovia SC-492 - Km 10 - B. Industrial
89905-000 - Bandeirante - SC
Fone: (49) 3622-4549
e-mail: mxmoveis@mxmoveis.com.br

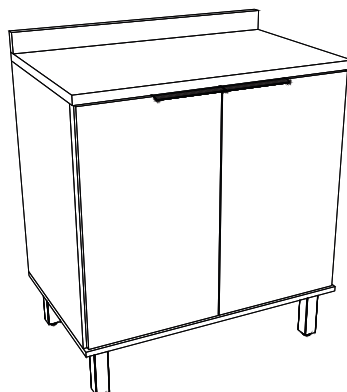

Ref. BTO02

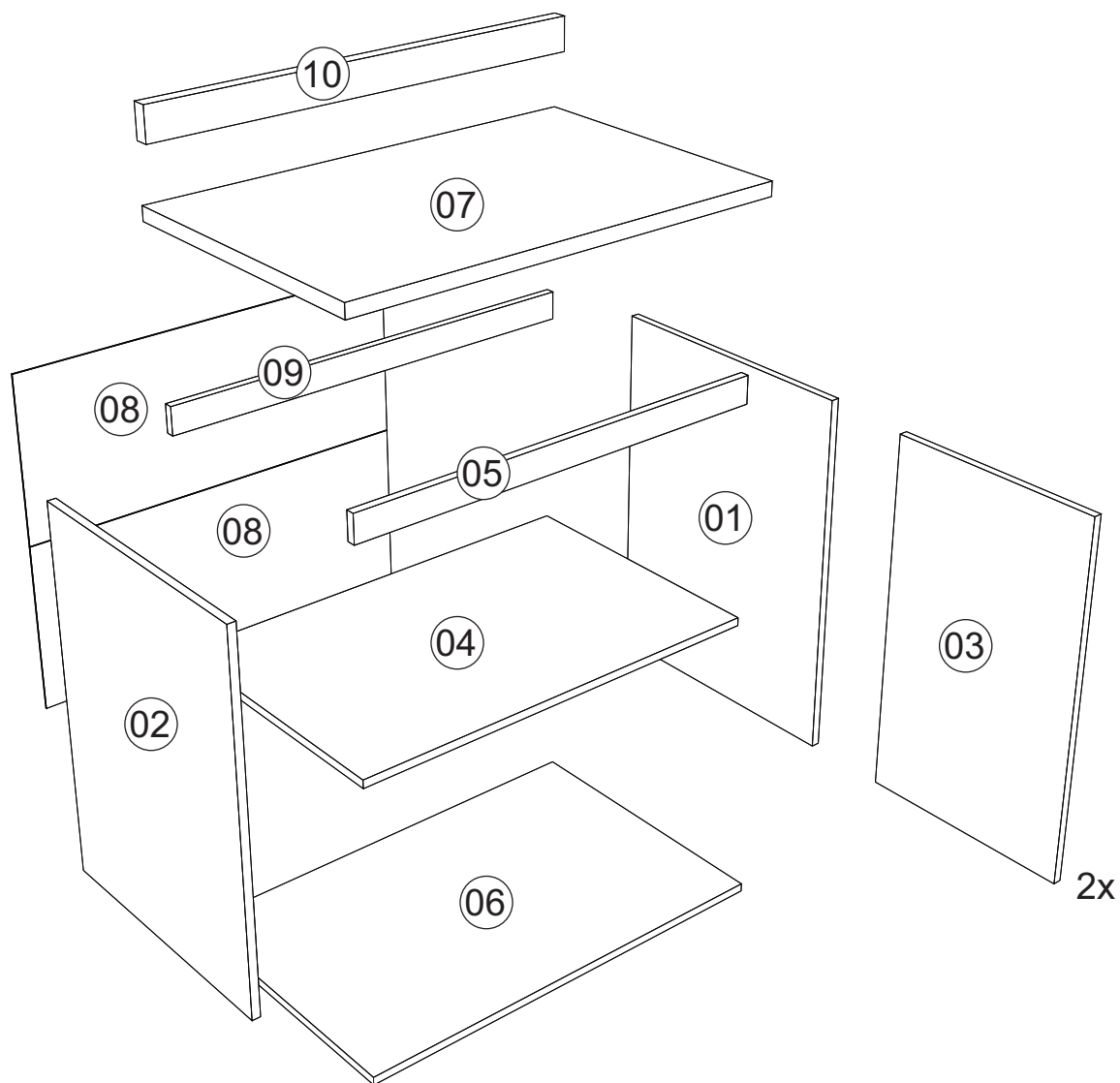

Balcão 800
Cozinha/Cocina
TOSCANA

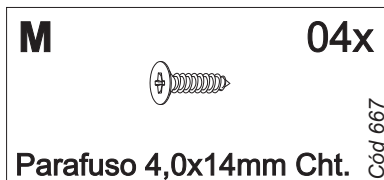
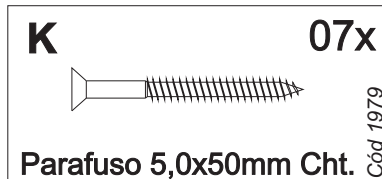
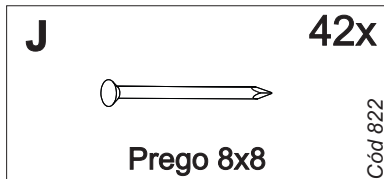
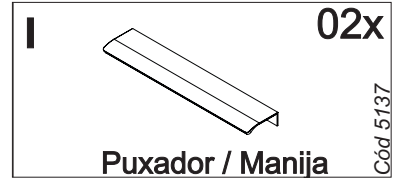
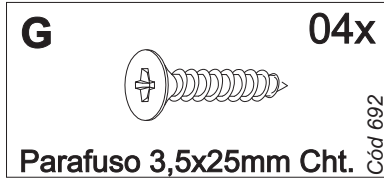
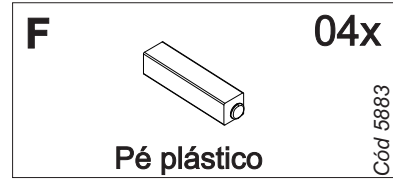
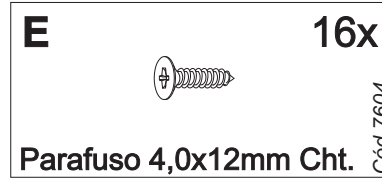
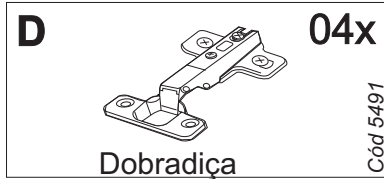
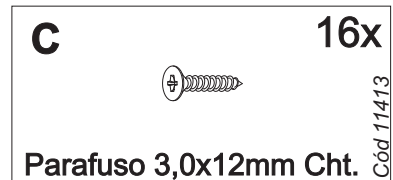
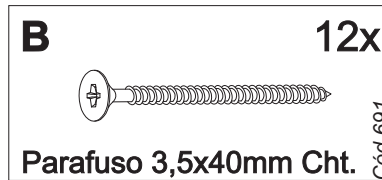
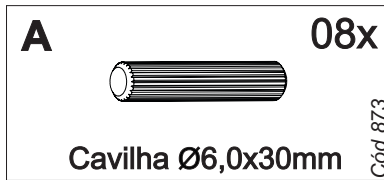

Nº	CÓDIGO ASSISTÊNCIA	NOME DA PEÇA/DESCRIPCIÓN PIEZAS	MEDIDAS (mm)	QTD.	CÓDIGO DAS PEÇAS		
					FREIJO/FREIJO	FREIJO/NERO	FREIJO/JADE
01	BTO02.17.00	Lateral externa direita/Lateral derecha	710x496x15	01	208841	208841	208841
02	BTO02.18.00	Lateral externa esquerda/Lateral izquierda	710x496x15	01	208842	208842	208842
03	BTO02.25.00	Porta balcão/Puerta	702x389x15	02	208878	208967	208959
04	BTO02.02.00	Base interna/Base pequena	770x450x15	01	208843	208843	208843
05	BTO02.28.00	Ripa balcão frontal/Travesaño	770x50x15	01	208846	208846	208846
06	BTO02.01.02	Base inferior/Base inferior	800x516x15	01	208849	208849	208849
07	BTO02.33.01	Tampo balcão/Tapa	800x516x22	01	208848	208848	208848
08	BTO02.13.00	Forro/Revés	790x336x2.5	02	208844	208844	208844
09	BTO02.28.01	Ripa balcão traseira/Travesaño	770x50x15	01	208845	208845	208845
10	BTO02.51.00	Roda tampo/Rueda Superior	800x60x22	01	208847	208847	208847

Ferragens/Herrajes



 *Usar os parafusos (G) para unir este módulo a outro.  Usar los tornillos (G) para unirse este módulo a otro.

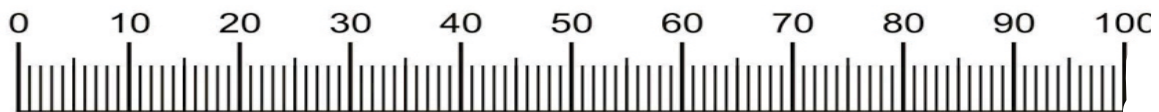

Medidas em mm

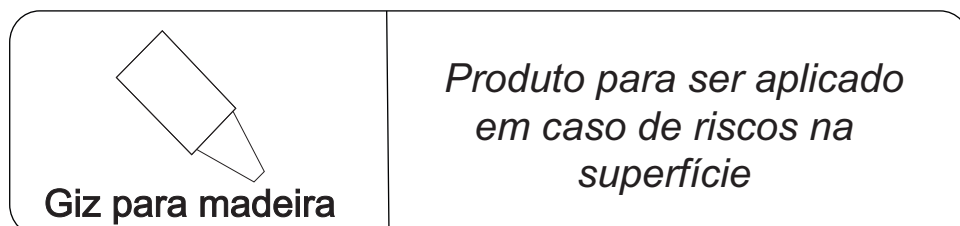
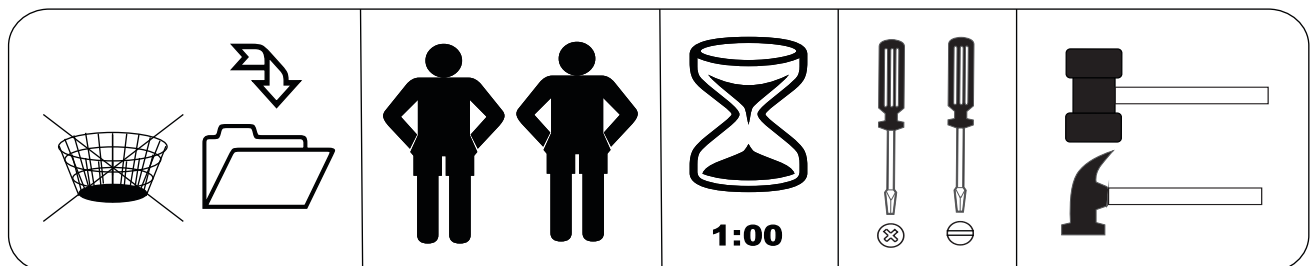

Pré-Montagem/Preparación Piezas



Utilizar
cola nas
cavilhas.

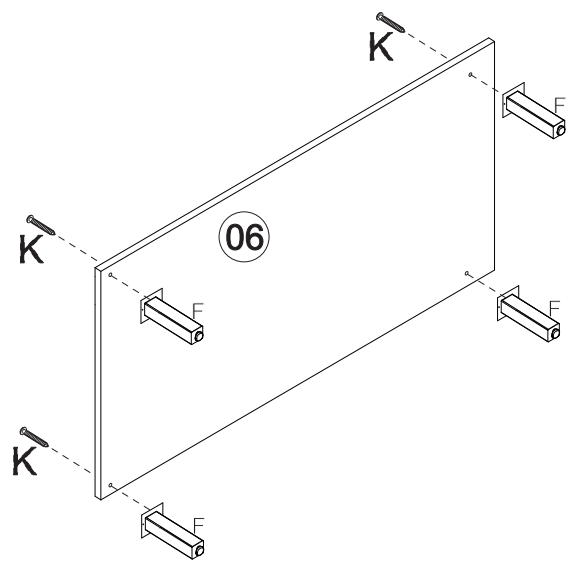
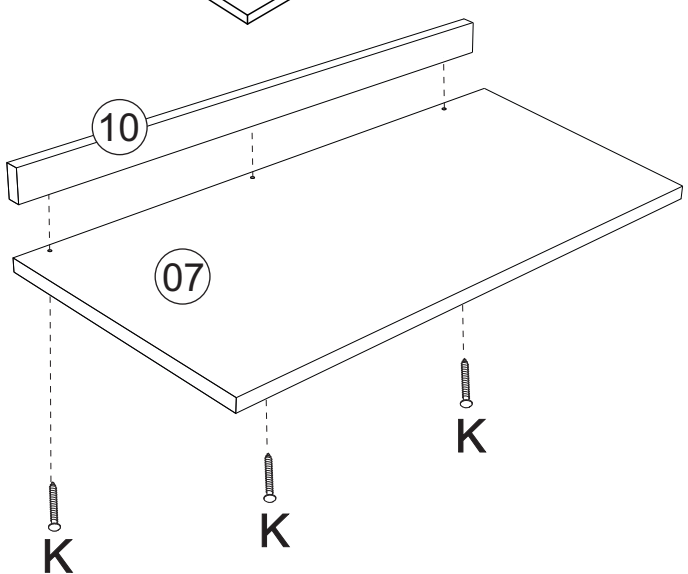
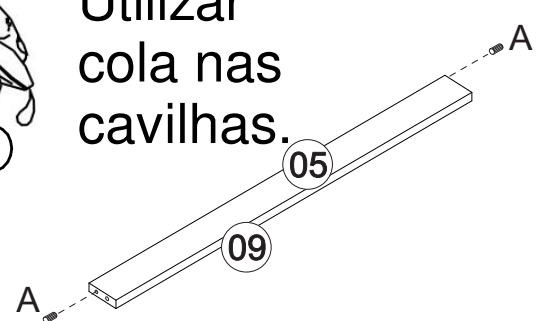
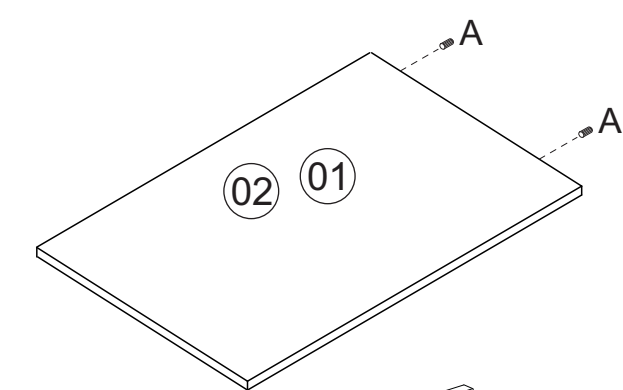

01

Montagem/Montaje

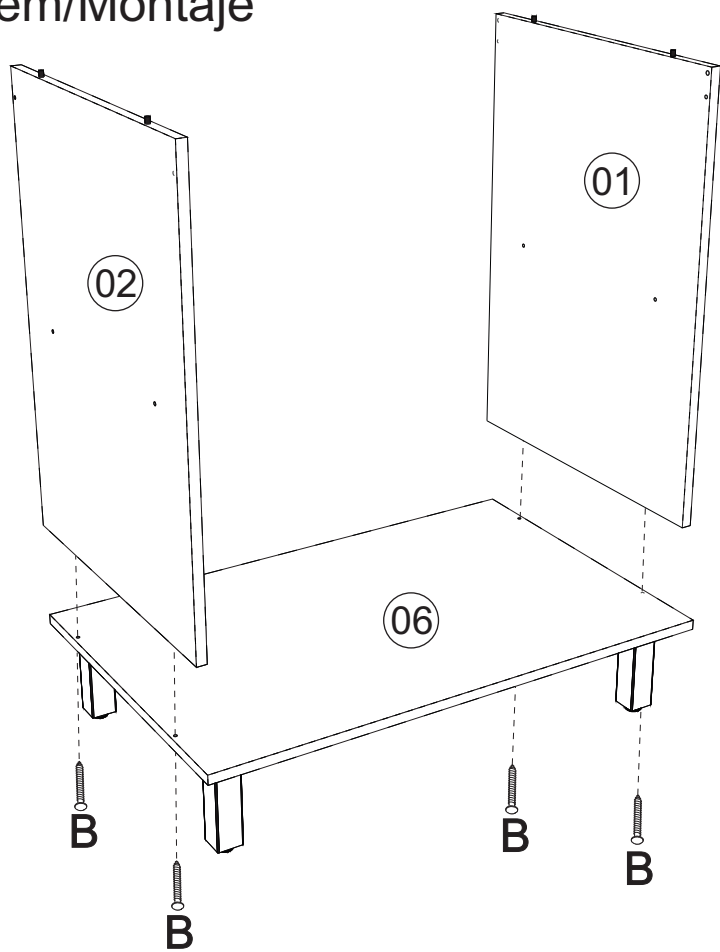

02 Montagem/Montaje

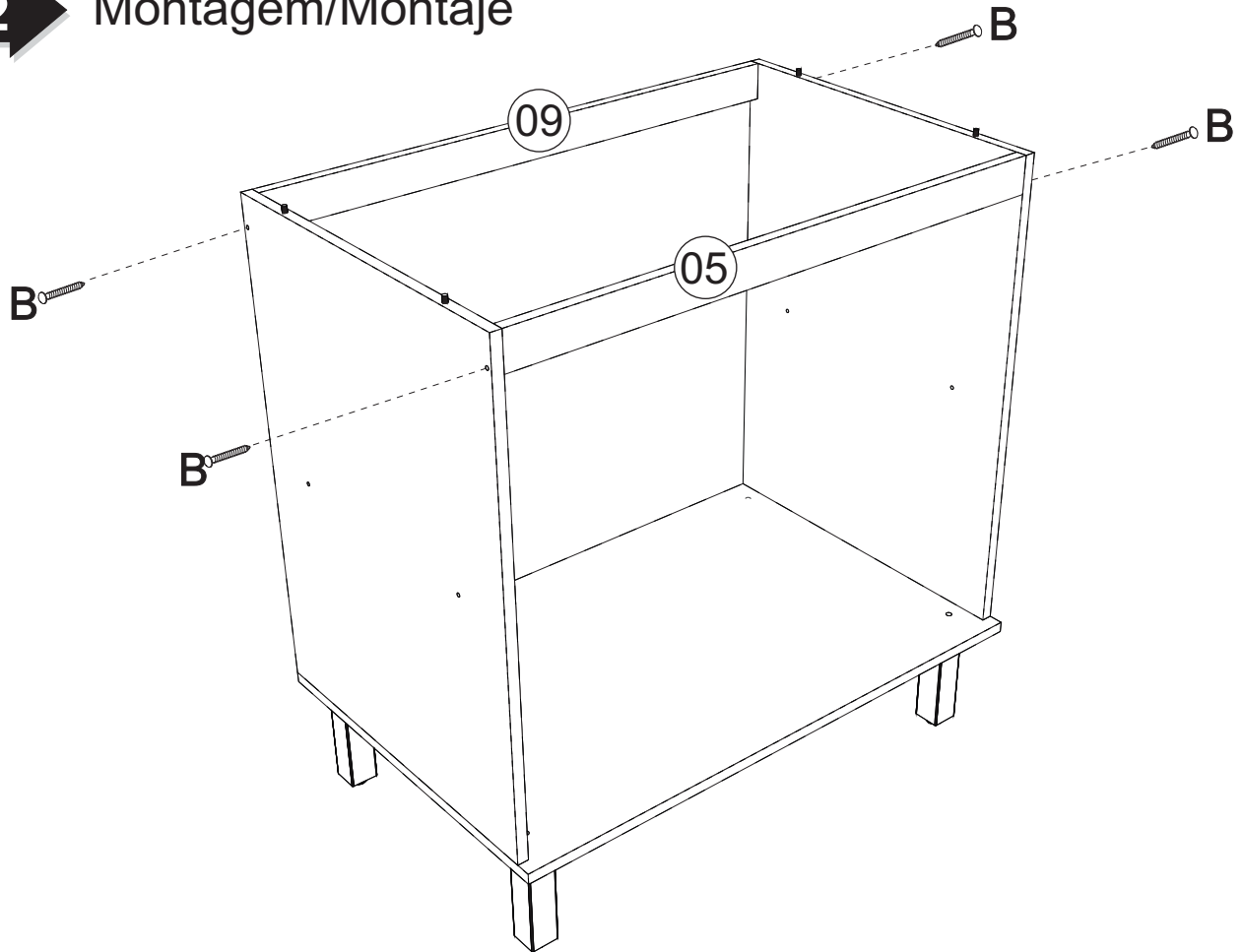

03 Montagem/Montaje

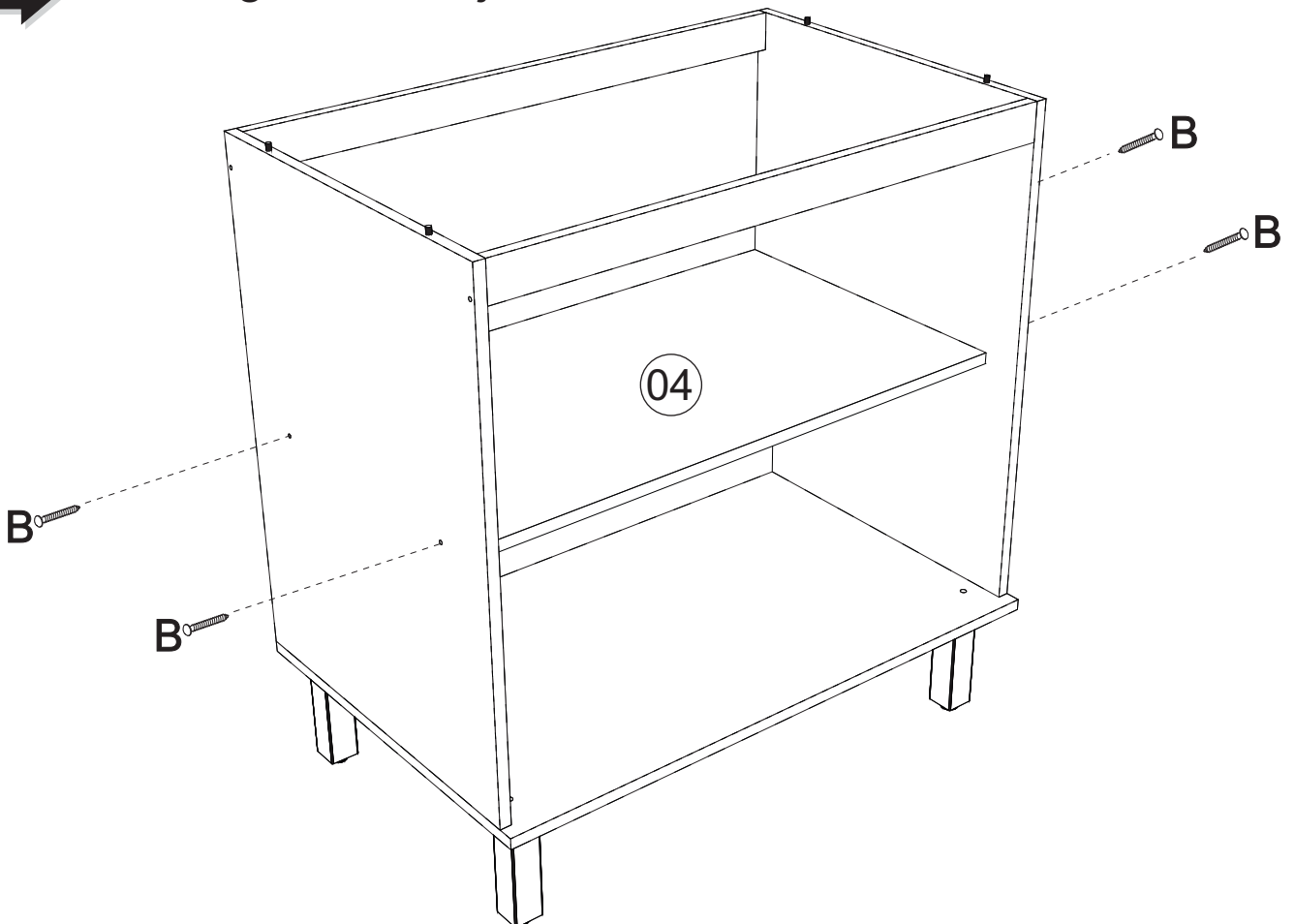

04 Montagem/Montaje

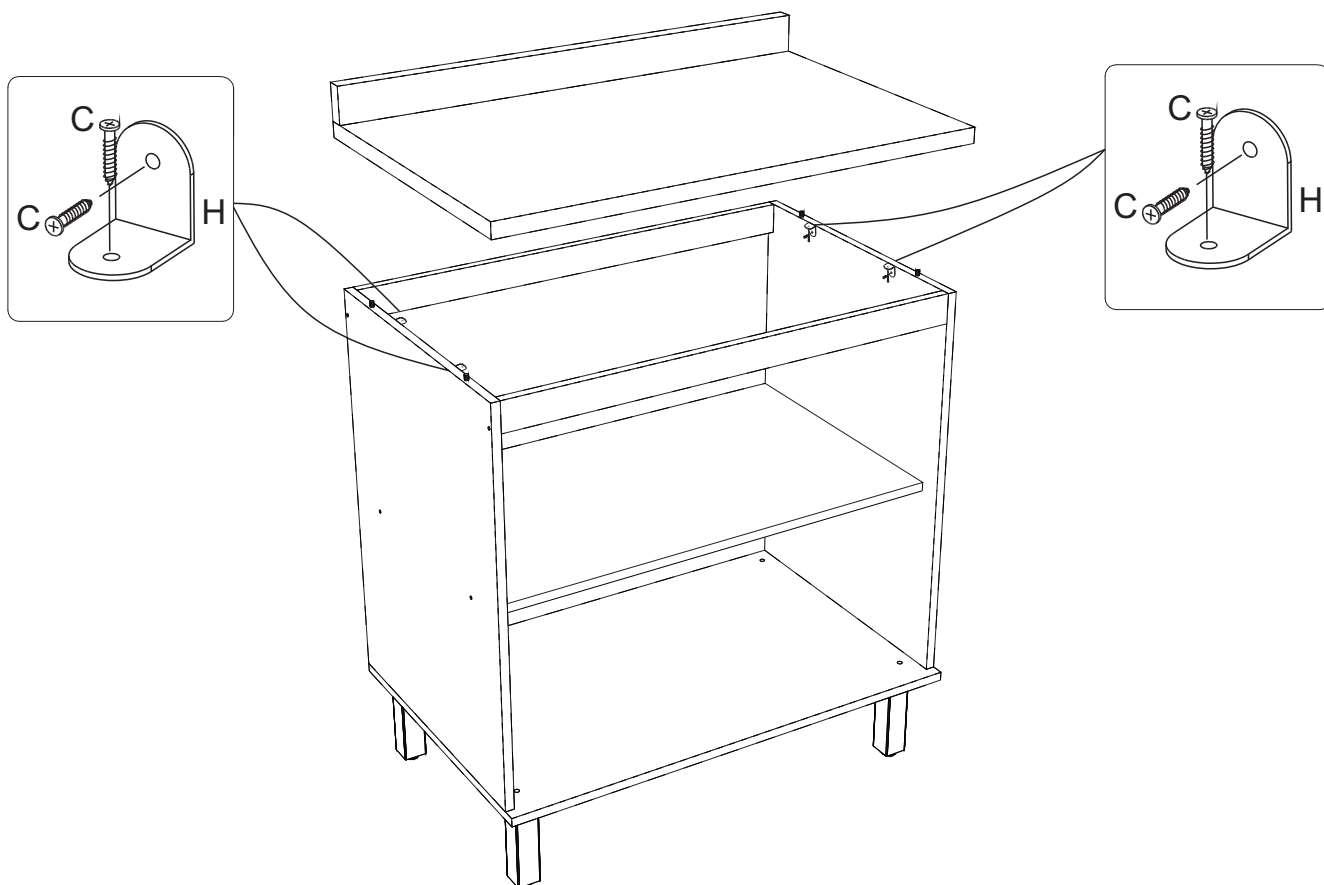

05 Montagem/Montaje

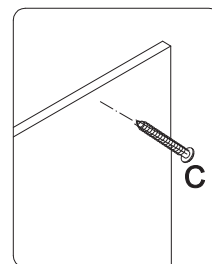
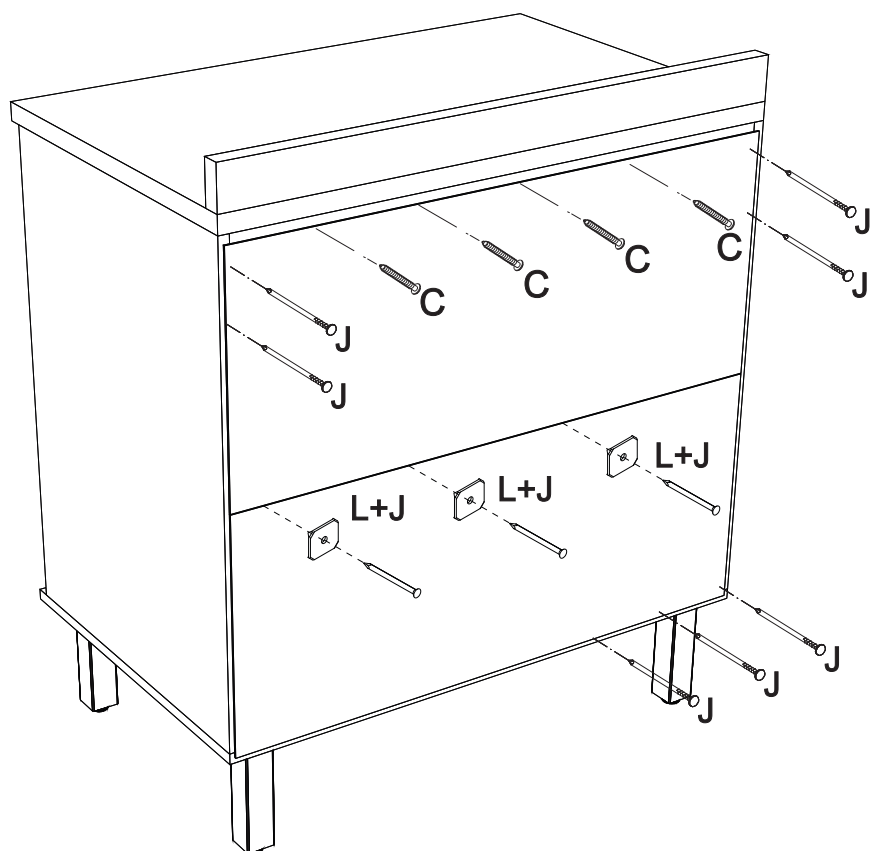

*Colocar um parafuso (C) a cada 100mm

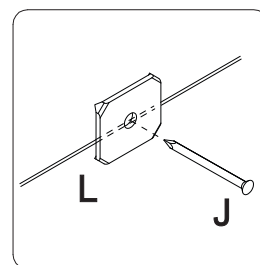

*Colocar o prego (J) e a junção (L) a cada 100mm

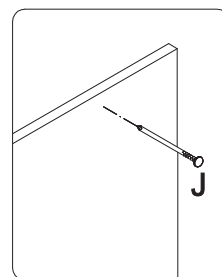

*Colocar um prego (J) a cada 100mm

06 Montagem/Montaje

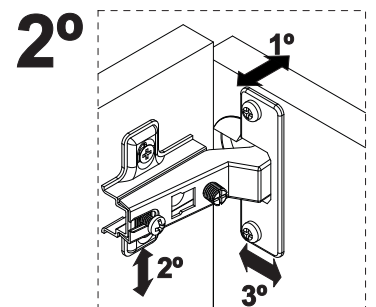
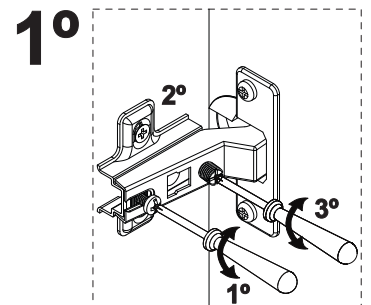
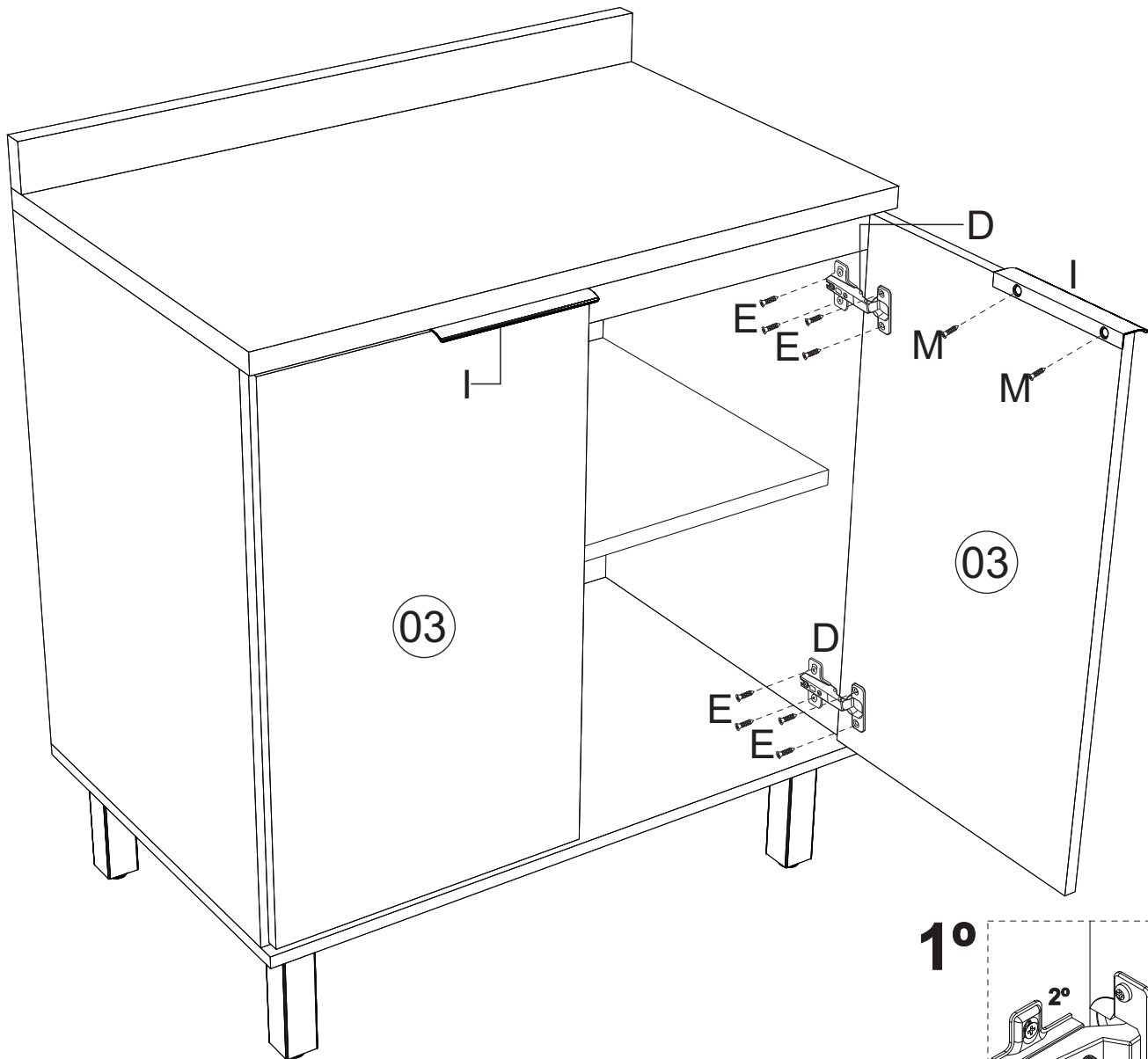
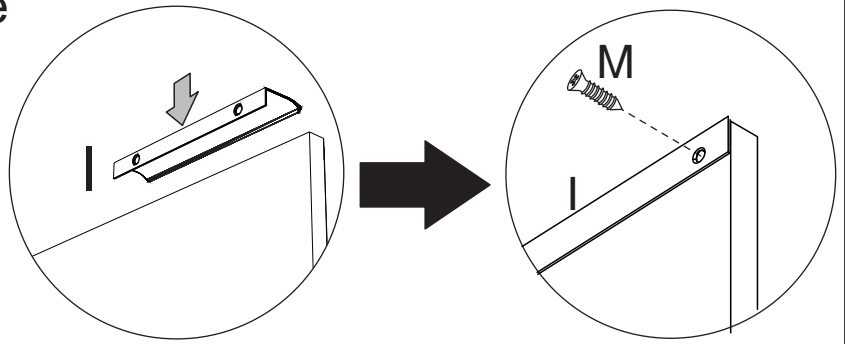

Limpeza/Limpieza

- ≠ Use um pano levemente umedecido com água, seguido de pano seco.
- ≠ Use solamente un paño húmedo con agua y después un paño seco.
- ≠ Nunca utilize produtos químicos ou abrasivos.
- ≠ No utilice productos químicos o abrasivos.



Rodovia SC-492 - Km 10 - B. Industrial
89905-000 - Bandeirante - SC
Fone: (49) 3622-4549
e-mail: mxmoveis@mxmoveis.com.br

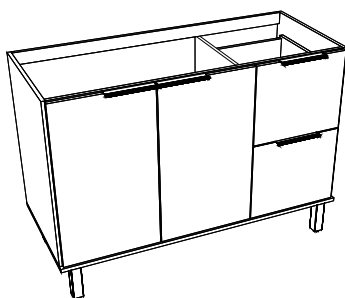

Ref. BTO03

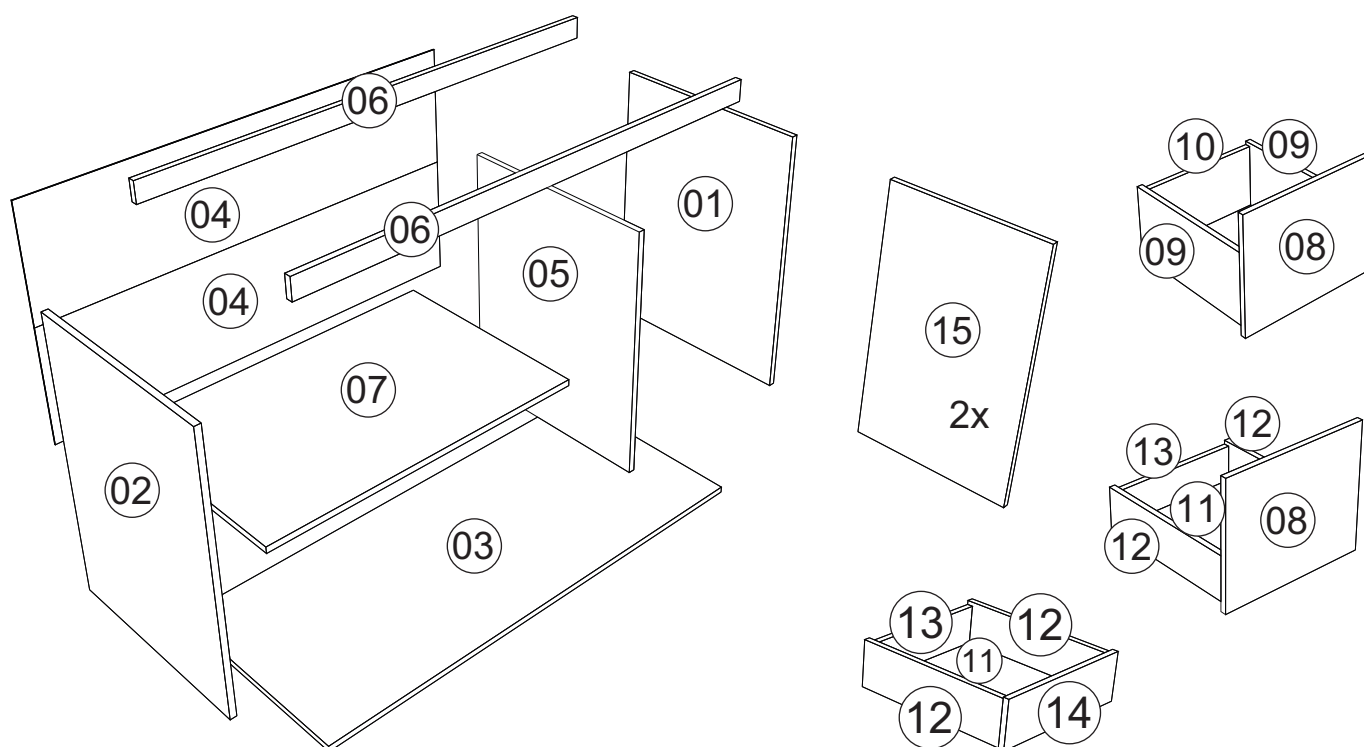

Balcão 1200 2P 3G
Cozinha/Cocina
TOSCANA



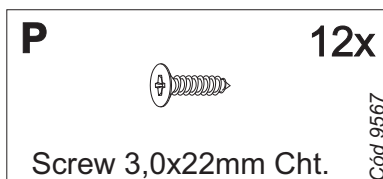
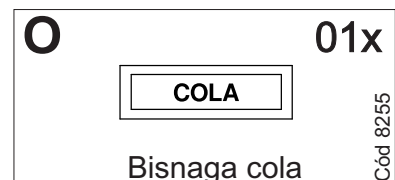
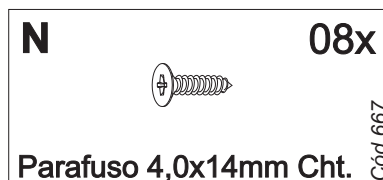
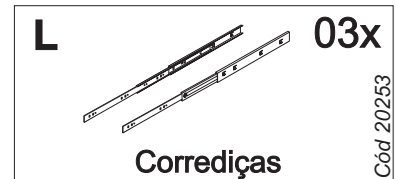
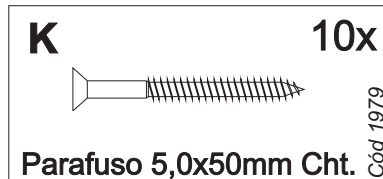
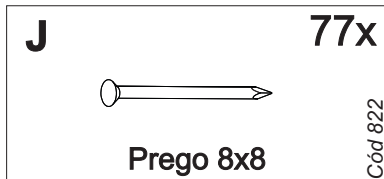
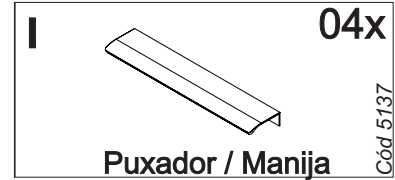
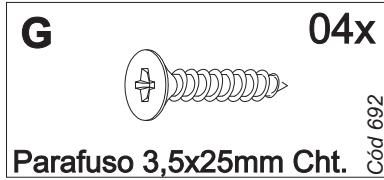
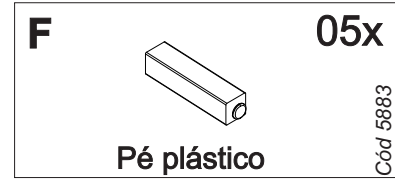
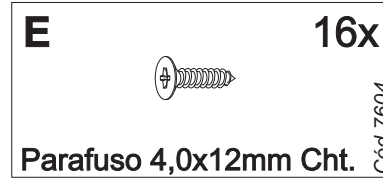
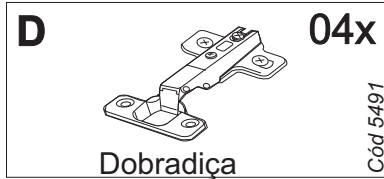
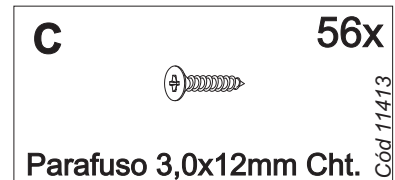
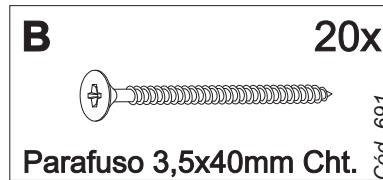
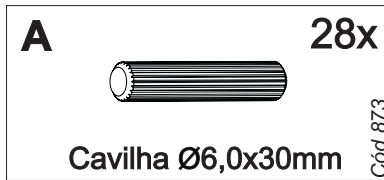

Nº	CÓDIGO ASSISTÊNCIA	NOME DA PEÇA/DESCRIPCIÓN PIEZAS	MEDIDAS (mm)	QTD	CÓDIGO DAS PEÇAS/ CÓDIGO PIEZAS		
					FREIJÓ/FREIJÓ	FREIJÓ/NERO	FREIJÓ/JADE
01	BTO03.17.00	Lateral externa direita/Lateral derecha	710x496x15	01	208894	208894	208894
02	BTO03.18.00	Lateral externa esquerda/Lateral izquierda	710x496x15	01	208895	208895	208895
03	BTO03.01.01	Base inferior/Base inferior	1200x516x15	01	208907	208907	208907
04	BTO03.13.00	Forro/Revés	1190x337x2.5	02	208900	208900	208900
05	BTO03.20.00	Lateral interna/Lado interno	660x496x15	01	208896	208896	208896
06	BTO03.28.00	Ripa balcão frontal/Travesaño	1170x50x15	02	208897	208897	208897
07	BTO03.02.00	Base interna/Base pequena	795x360x15	01	208899	208899	208899
08	BTO03.14.00	Frente gaveta/Frente cajón	370x349x15	02	208986	209123	208975
09	BTO03.15.00	Lateral gaveta/Lateral cajón	350x200x15	02	208901	208901	208901
10	BTO03.29.00	Ripa traseira gaveta/Trasero cajón	306x180x15	01	208903	208903	208903
11	BTO03.34.00	Forro gaveta/Revés cajón	330x355x15	03	208906	208906	208906
12	BTO03.15.01	Lateral gaveta/Lateral cajón	350x100x15	04	208902	208902	208902
13	BTO03.29.01	Ripa traseira gaveta/Trasero cajón	306x80x15	02	208904	208904	208904
14	BTO03.14.01	Frente gaveta/Frente cajón	340x130x15	01	208905	208905	210015
15	BTO03.25.00	Porta balcão/Puerta	702x401x15	02	208985	209119	208974
16	BTO03.28.01	Ripa balcão frontal/Travesaño	1170x50x15	01	208898	208898	208898

Ferragens/Herrajes



 *Usar os parafusos (G) para unir este módulo a outro. Usar los tornillos (G) para unirse este módulo a otro. 

*** Em caso de aquisição do tampo e roda tampo ***

 Este kit de ferragem possui 03 unidades a mais do parafuso (K), 8 (C) e 4 unidades do item (H). 



Medidas em mm

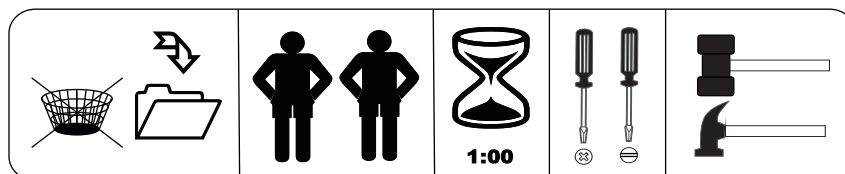

Produto para ser aplicado em caso de riscos na superfície

Pré-Montagem/Preparación Piezas

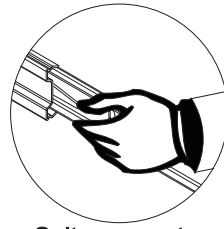
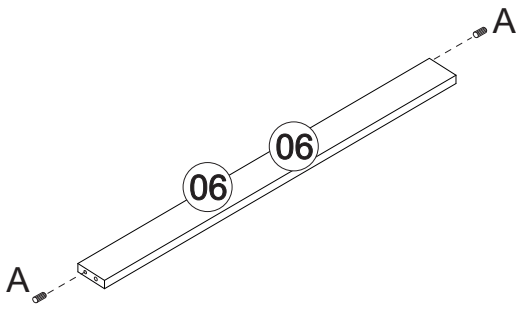

Soltar as partes da correia

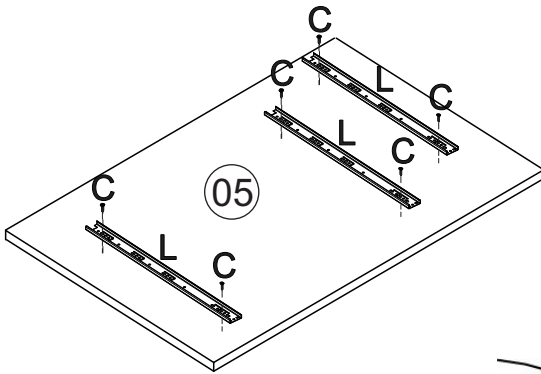
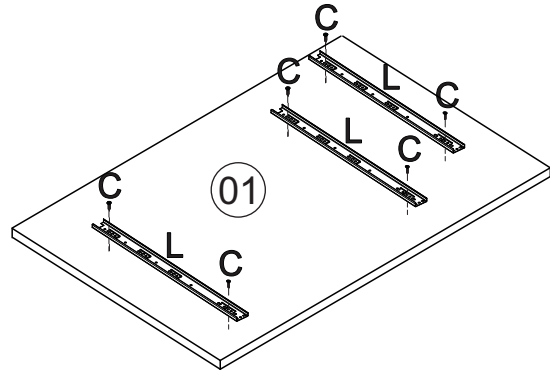
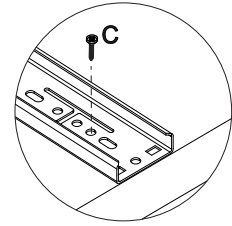

Utilizar cola nas cavilhas.

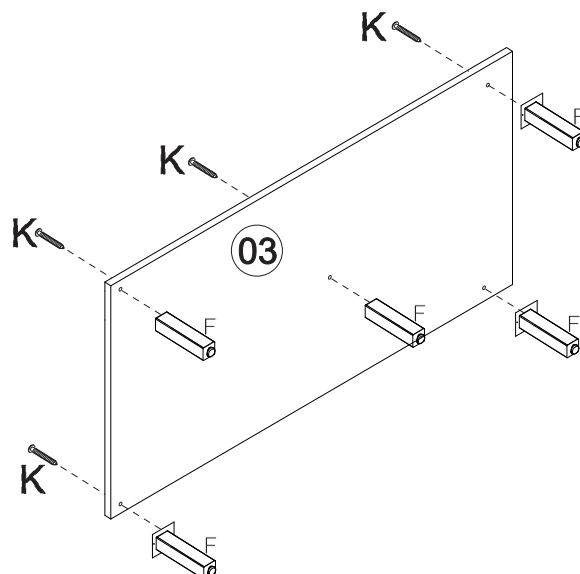
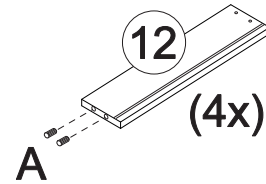
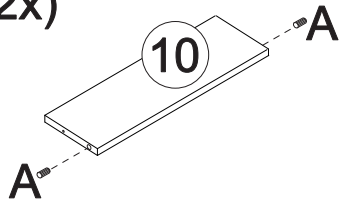
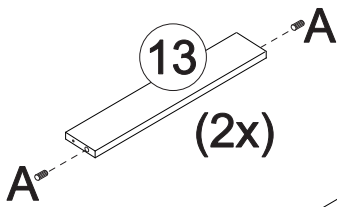
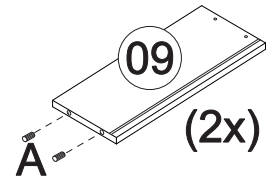

01 Montagem/Montaje

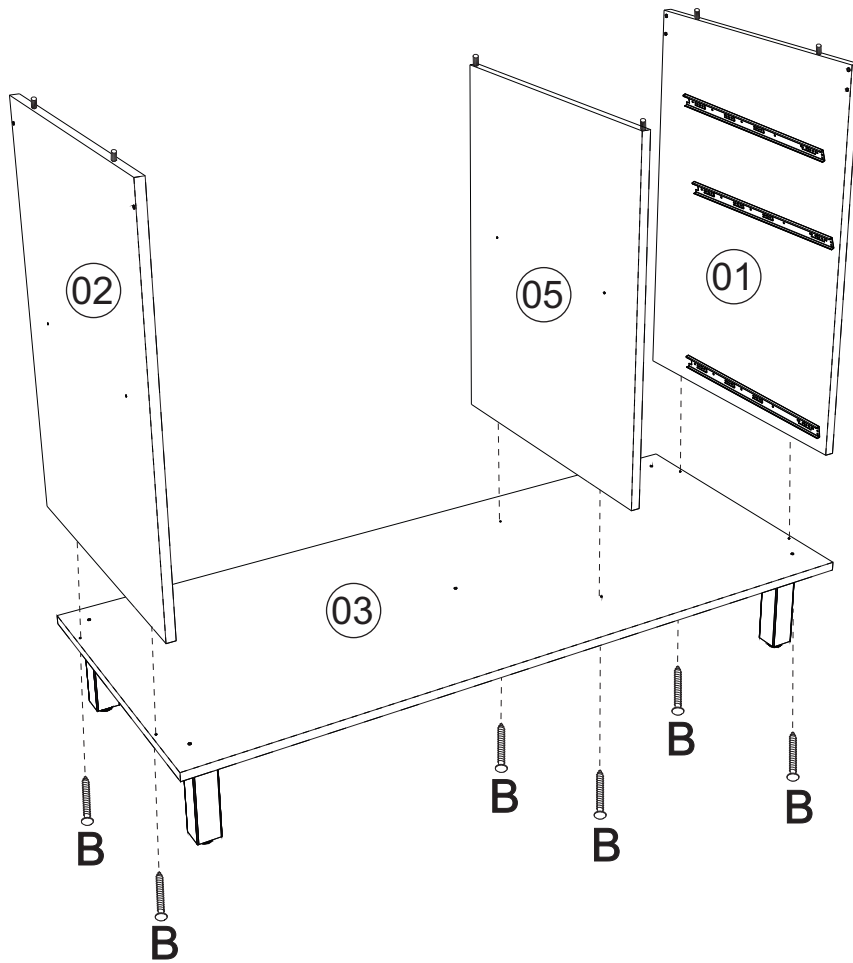

02 Montagem/Montaje

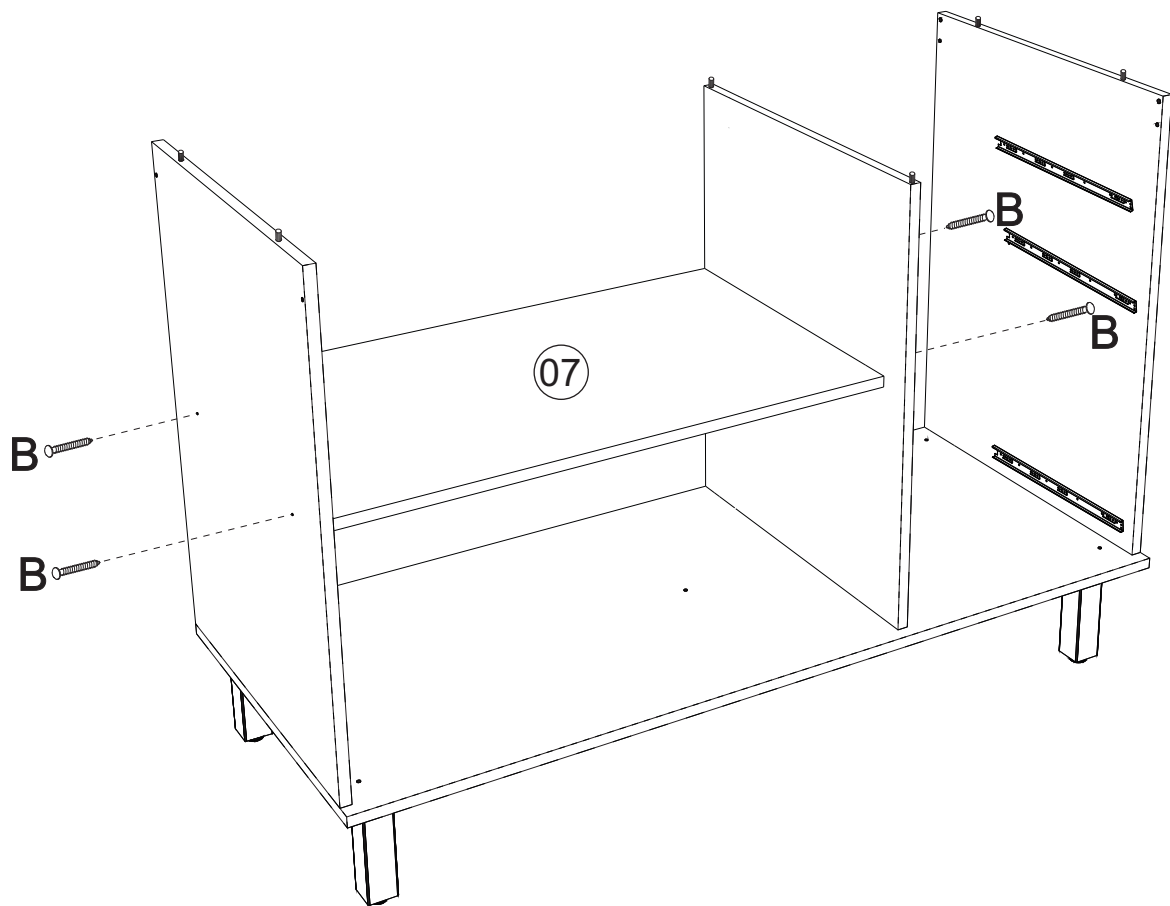

03 Montagem/Montaje

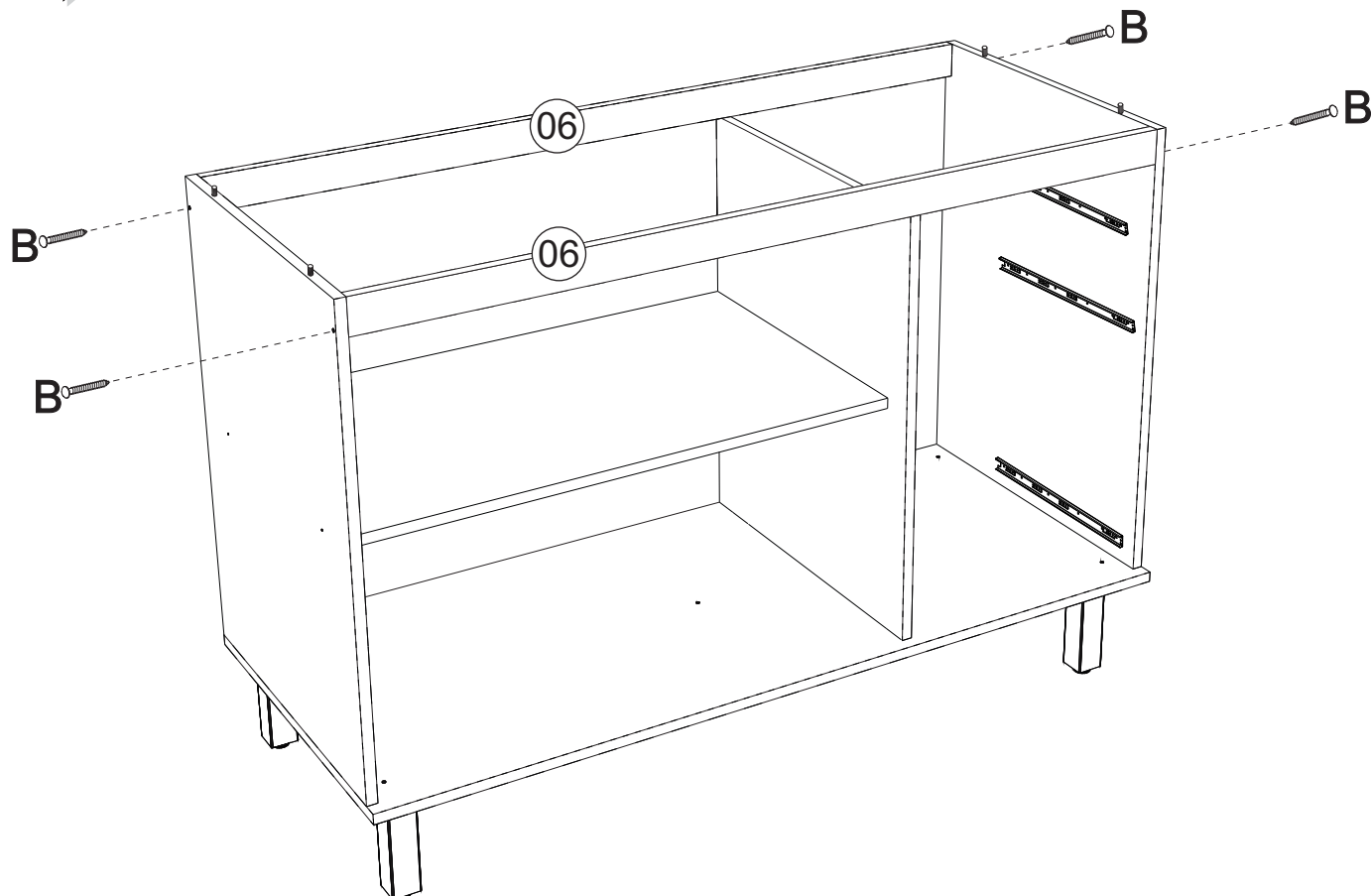

04 Montagem/Montaje

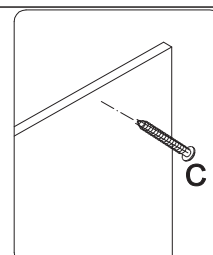
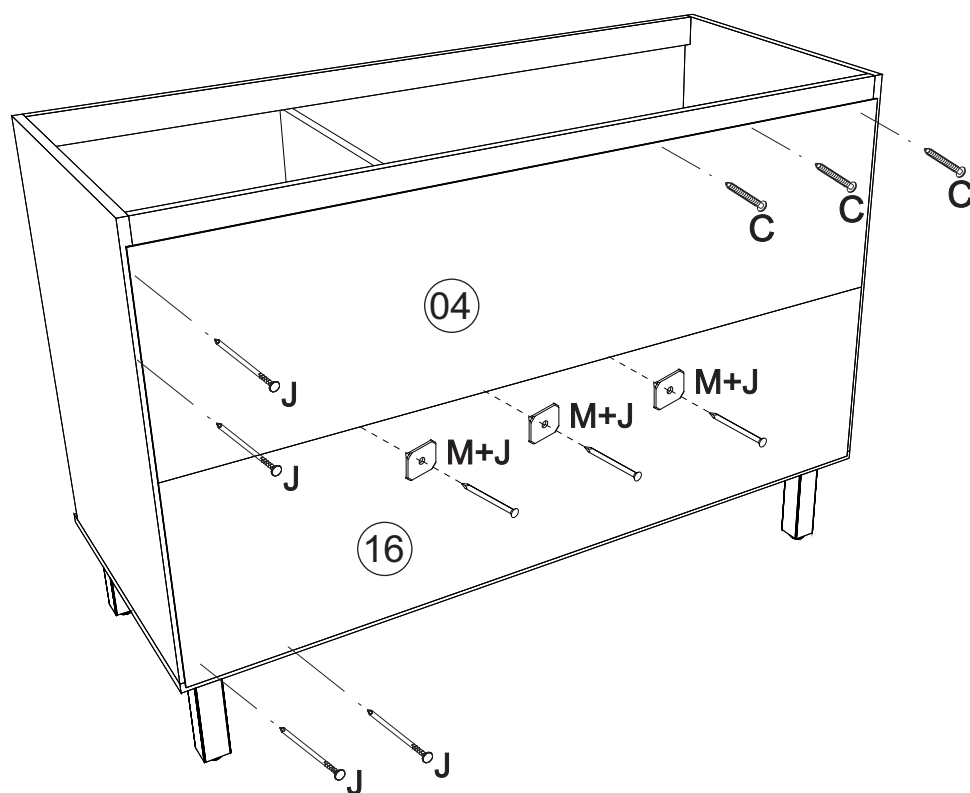

*Colocar um parafuso (C) a cada 100mm

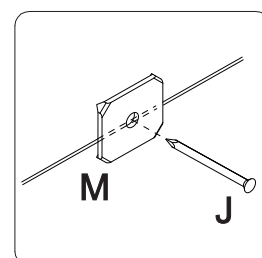

*Colocar o prego (J) e a junção (M) a cada 100mm

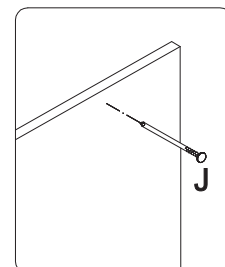

*Colocar um prego (J) a cada 100mm

05 Montagem/Montaje

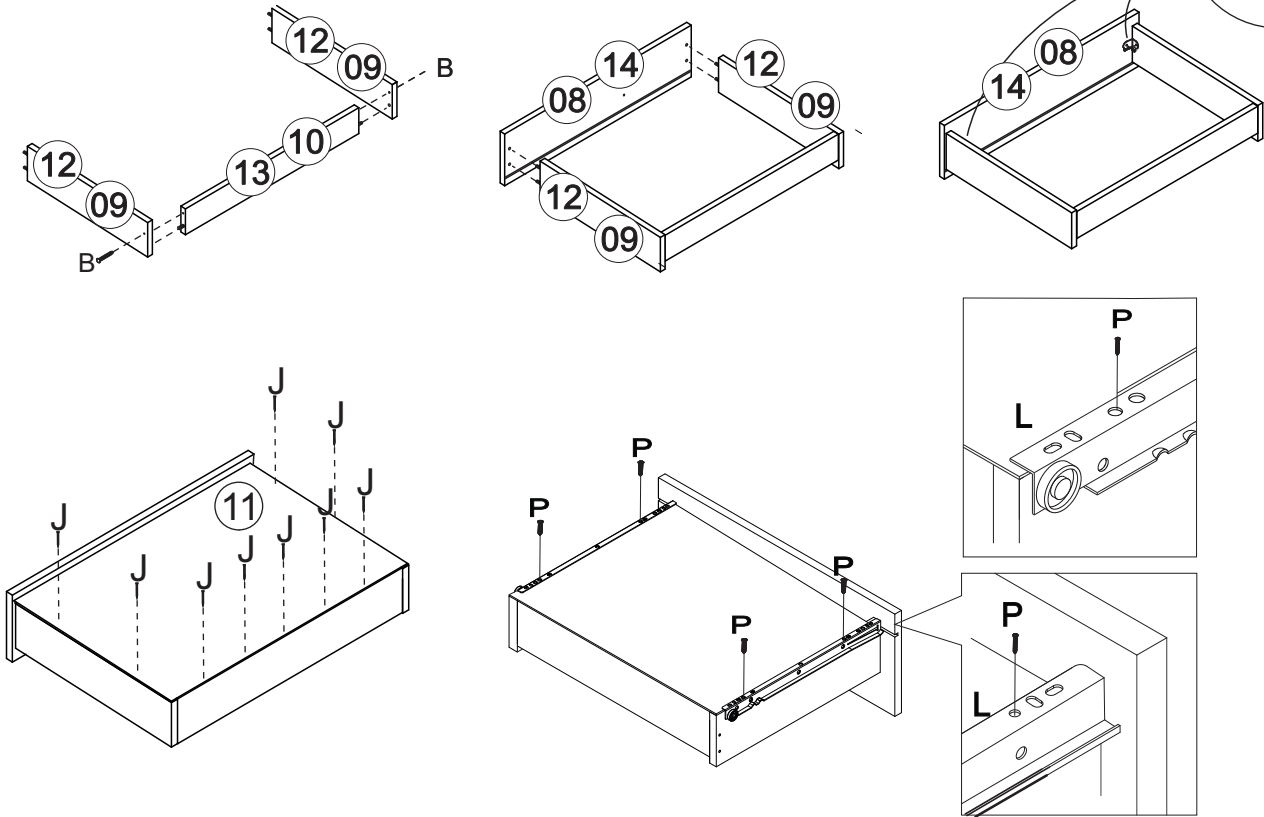
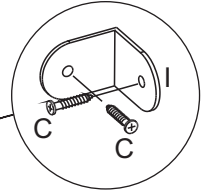

06 Montagem/Montaje

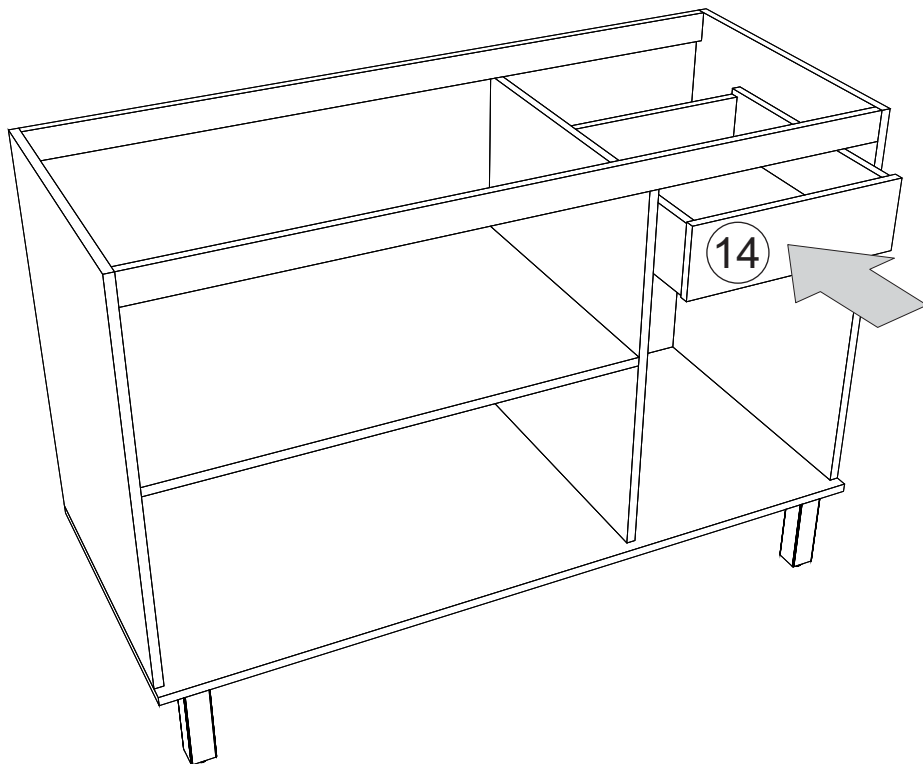



Rodovia SC-492 - Km 10 - B. Industrial
89905-000 - Bandeirante - SC
Fone: (49) 3622-4549
e-mail: mxmoveis@mxmoveis.com.br

Ref. BTO04

Balcão Canto
Balcón Esquinero
Cozinha/Cocina
TOSCANA

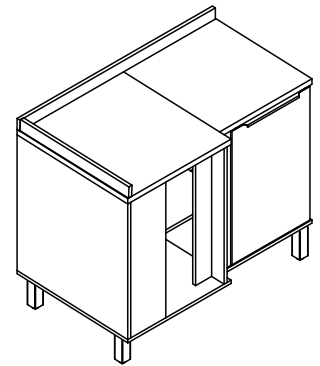
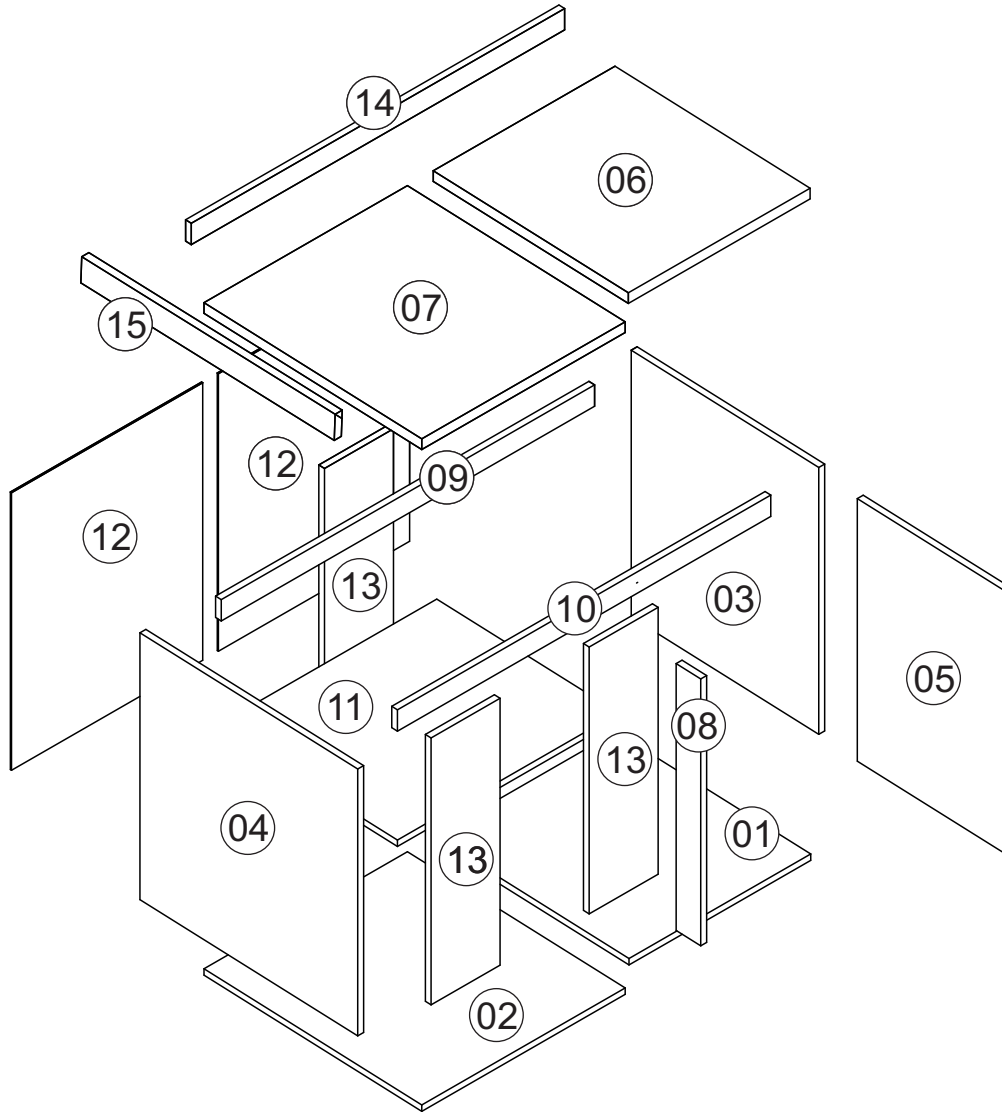

Direito/Derecho

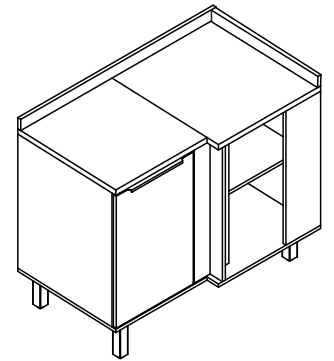



Esquerdo/Izquierdo

Nº	CÓDIGO ASSISTÊNCIA	NOME DA PEÇA/DESCRIPCIÓN PIEZAS	MEDIDAS (mm)	QTD.	CÓDIGO DAS PEÇAS/ CÓDIGO PIEZAS		
					FREIJÓ/FREIJÓ	FREIJÓ/NERO	FREIJÓ/JADE
01	BTO04.01.01	Base inferior/Base inferior	461x516x15	01	209041	209041	209041
02	BTO04.01.00	Base inferior/Base inferior	516x576x15	01	209039	209039	209039
03	BTO04.18.00	Lateral menor/Lateral menor	710x576x15	01	209037	209037	209037
04	BTO04.17.00	Lateral maior/Lateral mayor	710x496x15	01	209036	209036	209036
05	BTO04.25.00	Porta balcão/Puerta	702x376x15	01	209110	209117	209029
06	BTO04.33.01	Tampo/Tapa	516x461x22	01	209046	209046	209046
07	BTO04.33.00	Tampo/Tapa	516x576x22	01	209045	209045	209045
08	BTO04.06.00	Ripa batente/Travesaño	710x65x15	01	209038	209038	209038
09	BTO04.28.00	Ripa sustentação/Travesaño	947x50x15	02	209043	209043	209043
10	BTO04.28.01	Ripa balcão/Travesaño	947x50x15	01	209044	209044	209044
11	BTO04.02.00	Prateleira interna/Repisa	573x484x15	01	209042	209042	209042
12	BTO04.13.00	Forro balcão/Revés	724x474x2.5	02	209047	209047	209047
13	BTO04.06.01	Ripa batente/Travesaño	710x175x15	03	209040	209040	209040
14	BTO04.51.00	Roda tampo/Roda tampo	977x60x22	01	209048	209048	209048
15	BTO04.51.01	Roda tampo/Roda tampo	551x60x22	01	209049	209049	209049

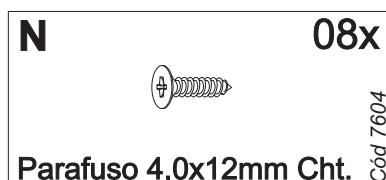
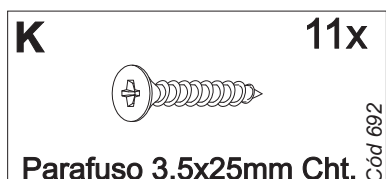
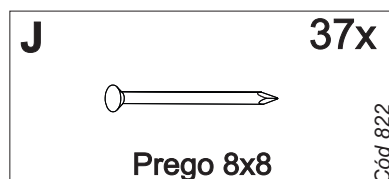
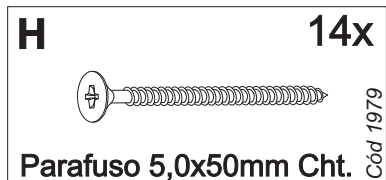
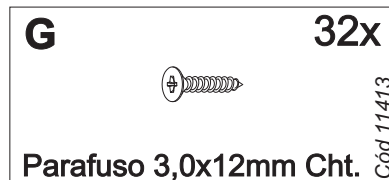
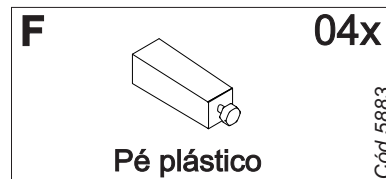
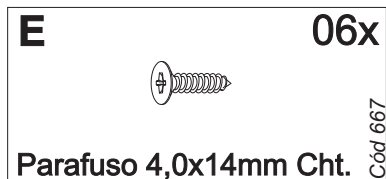
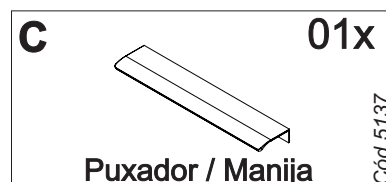
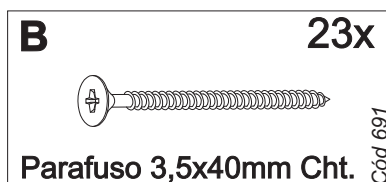
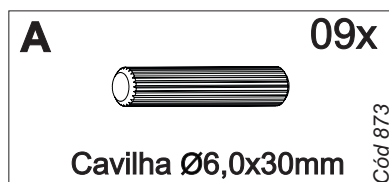
Ferragens/Herrajes



 *Usar os parafusos (K) para unir este módulo a outro. 
 Usar los tornillos (K) para unirse este módulo a otro.



Medidas em mm

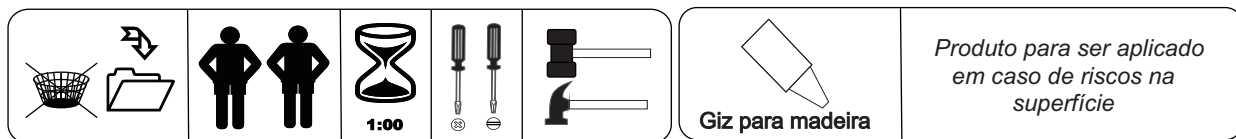

Pré-Montagem/Preparación Piezas

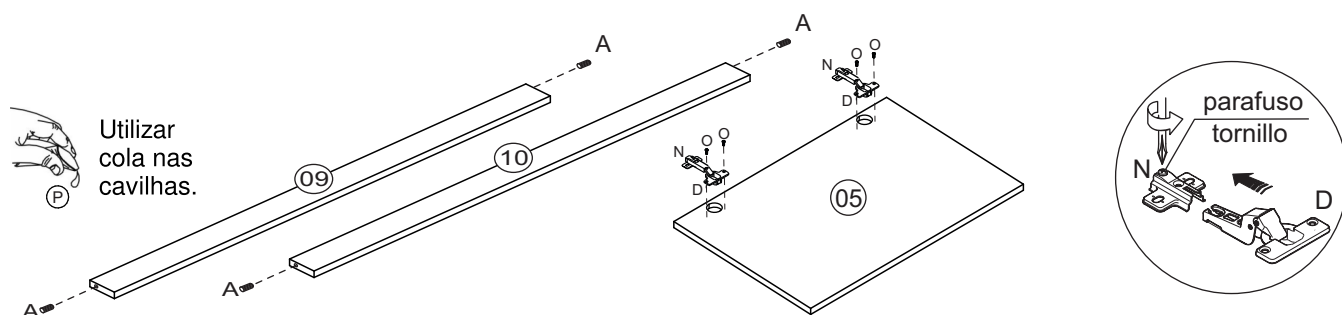

Montagem/Montaje

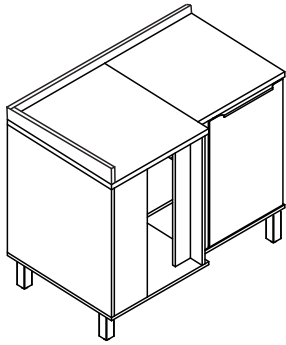

Direito/Derecho

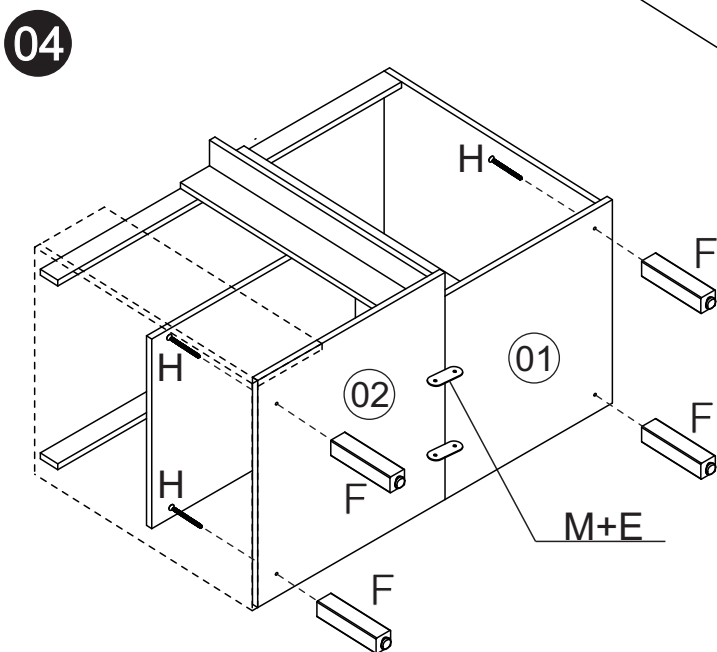
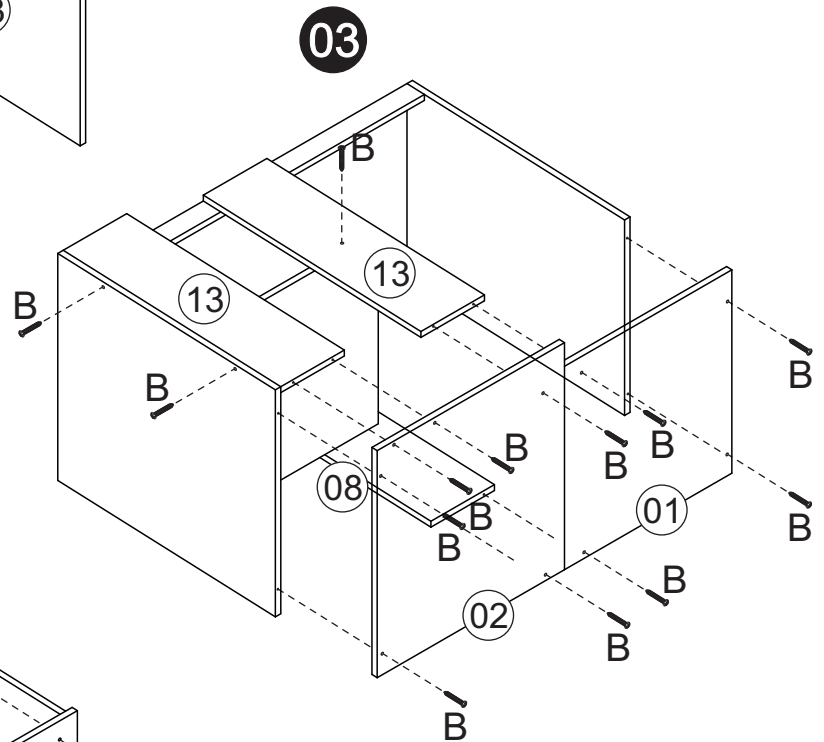
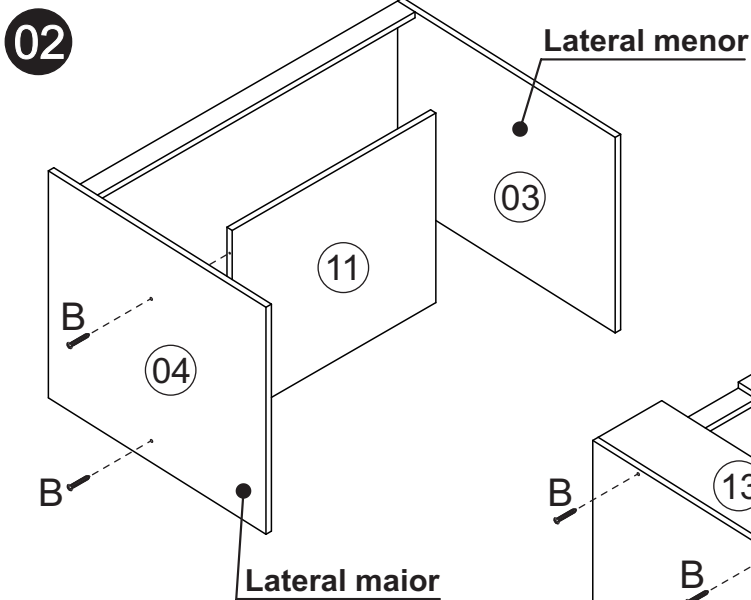
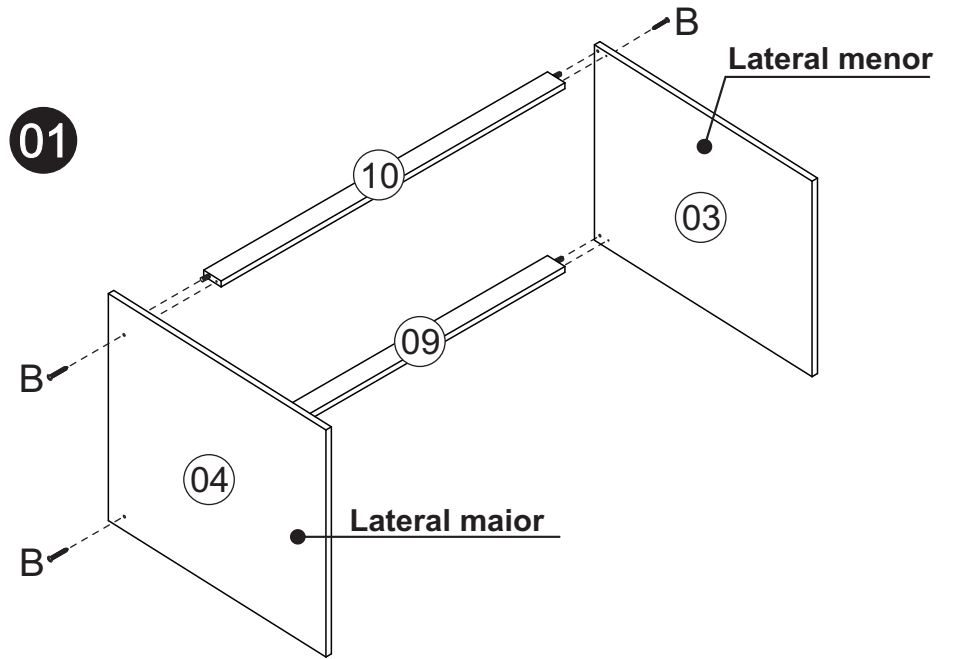

Montagem/Montaje

05

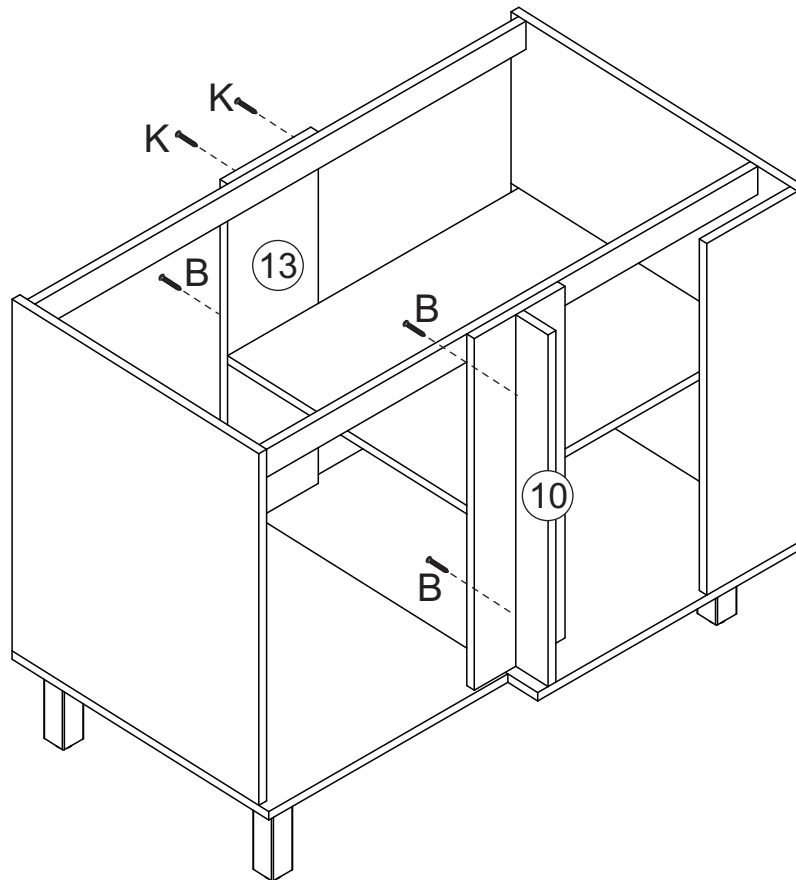

Obs: Roda tampo fixado no tampo com parafuso 5x50

06

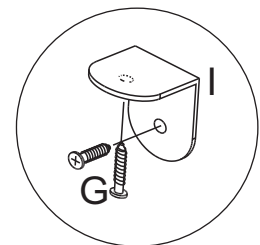
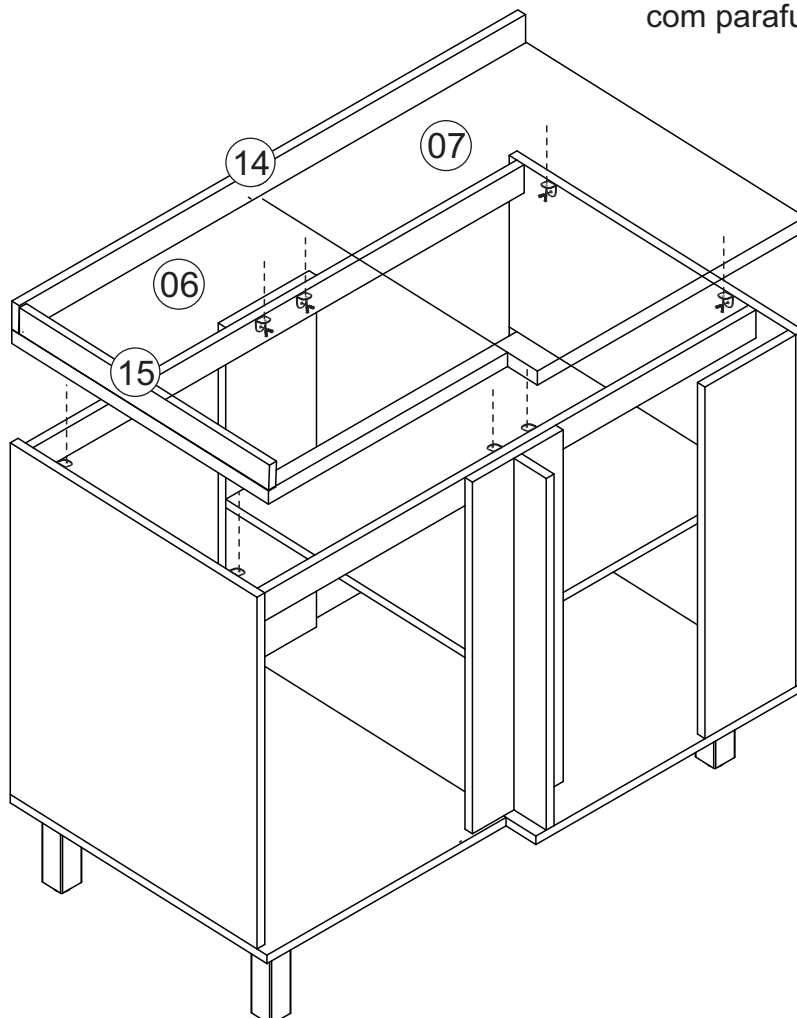

Montagem/Montaje

07

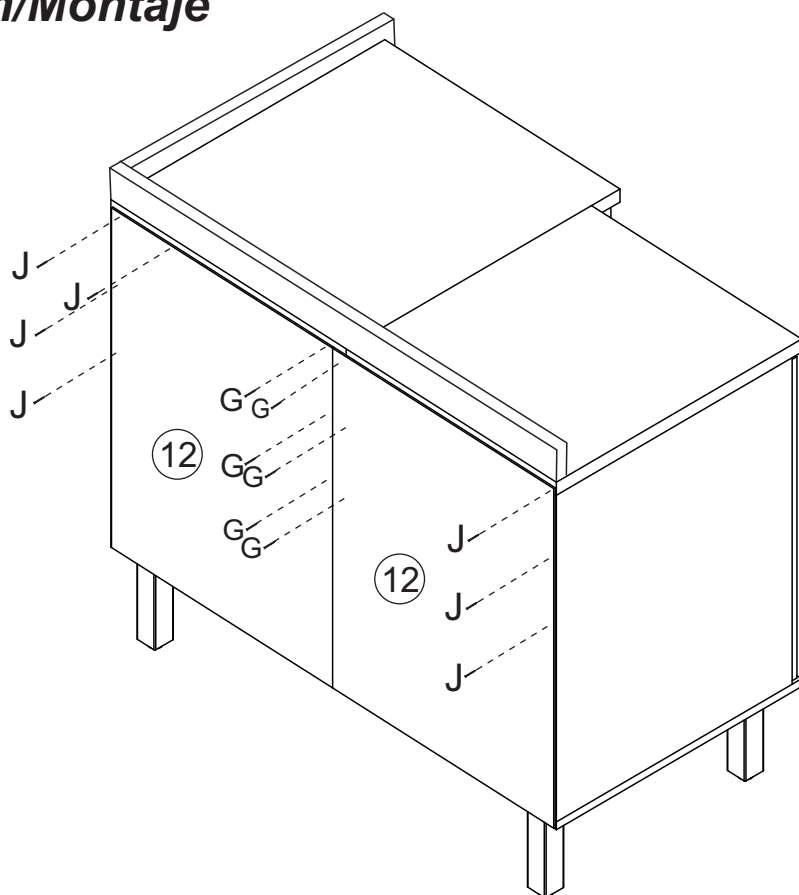

08

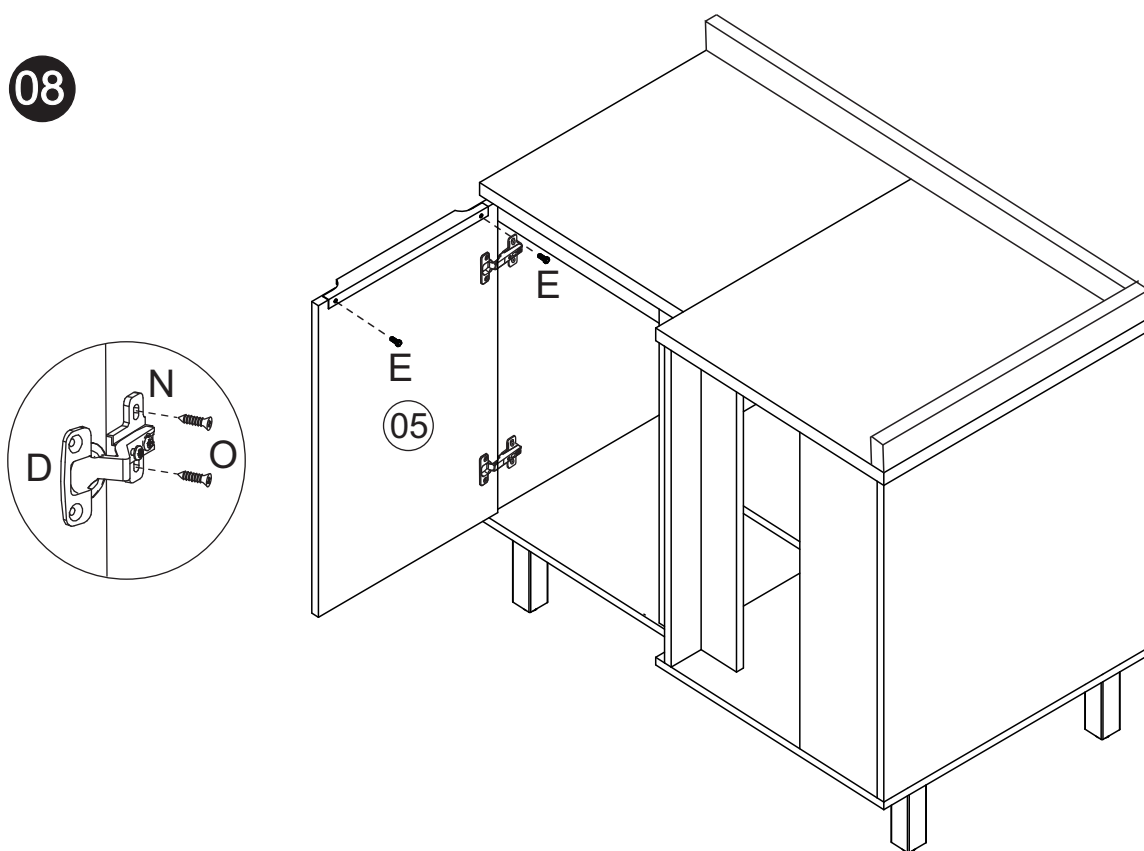

Montagem/Montaje

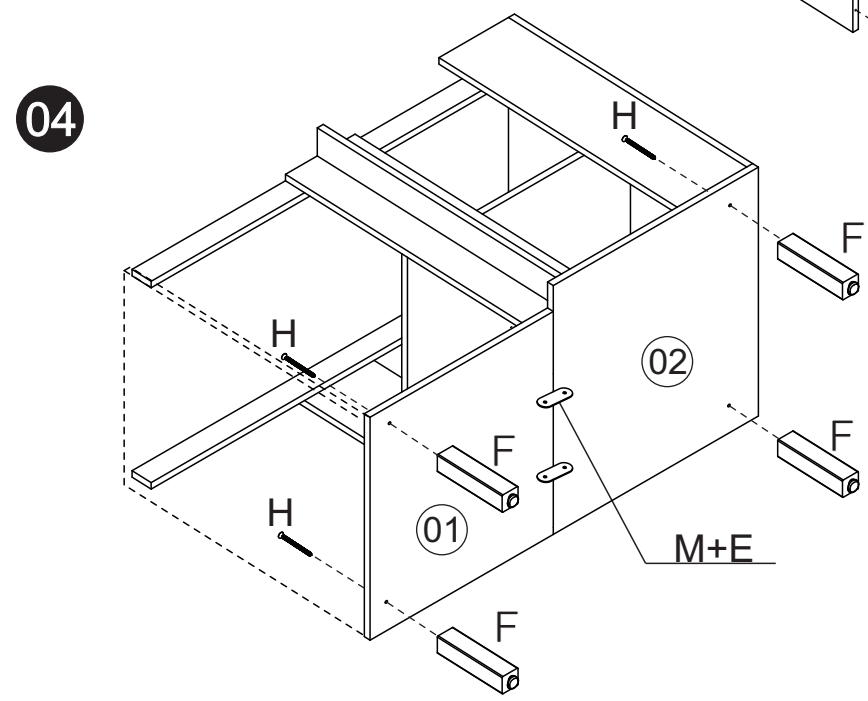
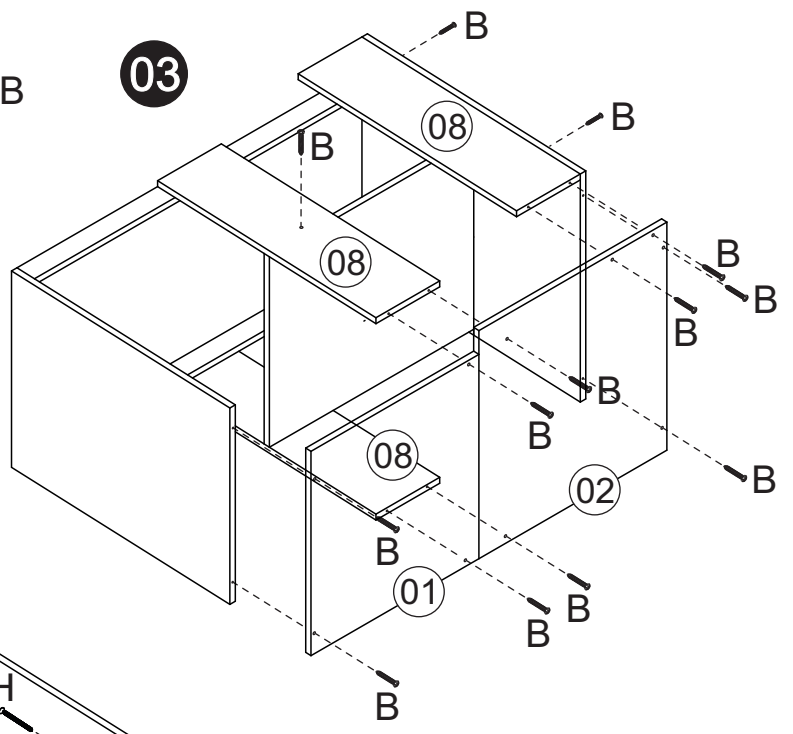
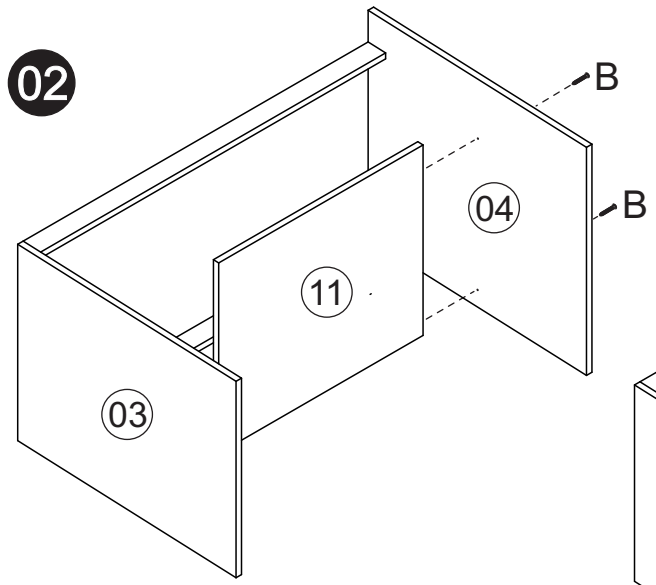
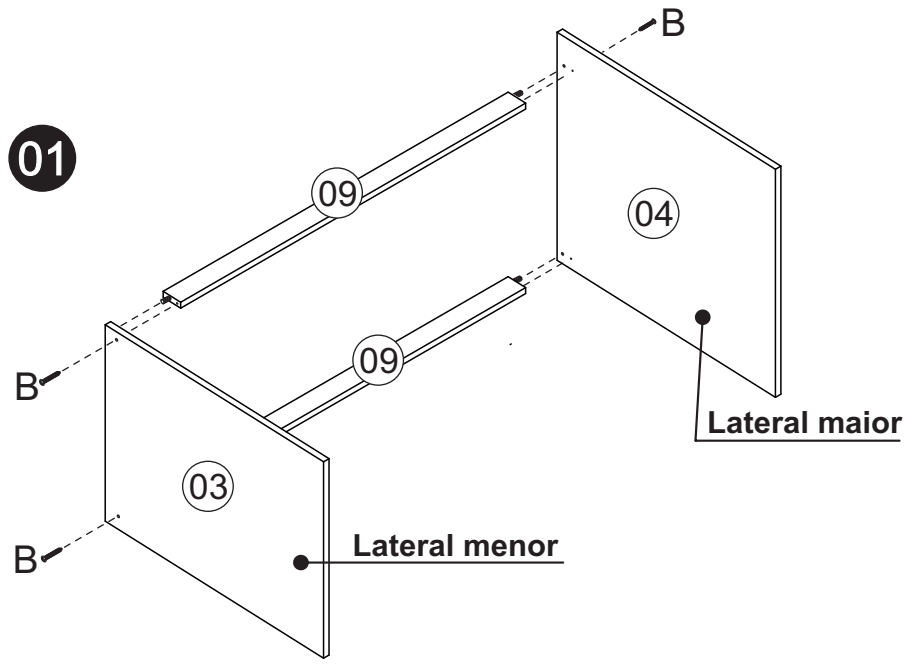
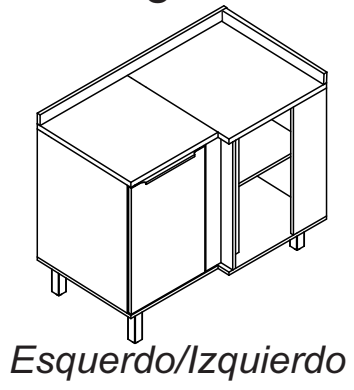

Montagem/Montaje

05

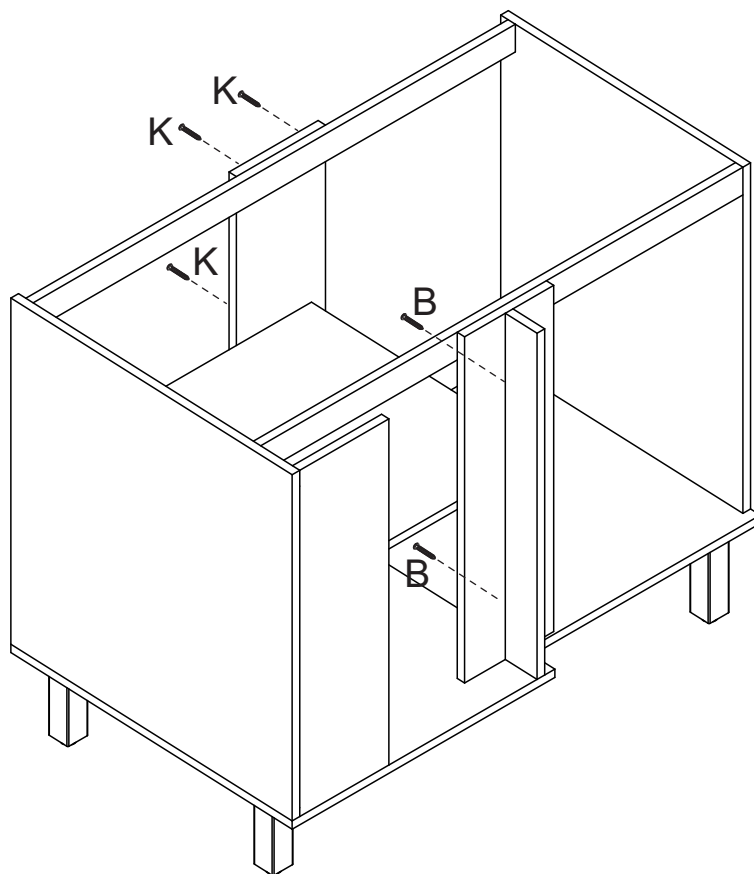

06

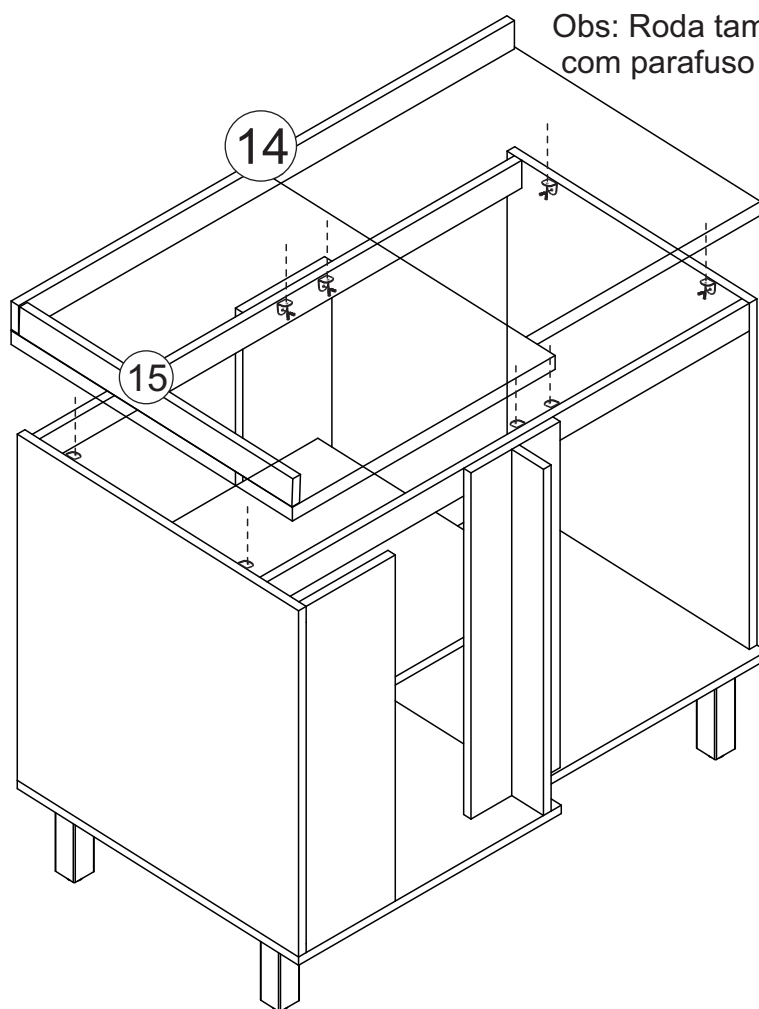

Obs: Roda tampo fixado no tampo com parafuso 5x50

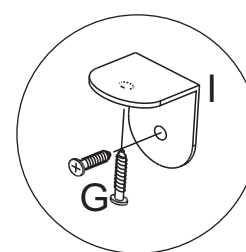

Montagem/Montaje

07

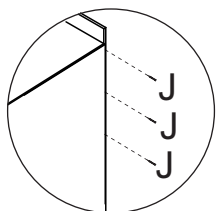

*Colocar um prego (J)
a cada 100mm.

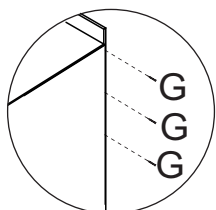

*Colocar um parafuso (G)
a cada 100mm.

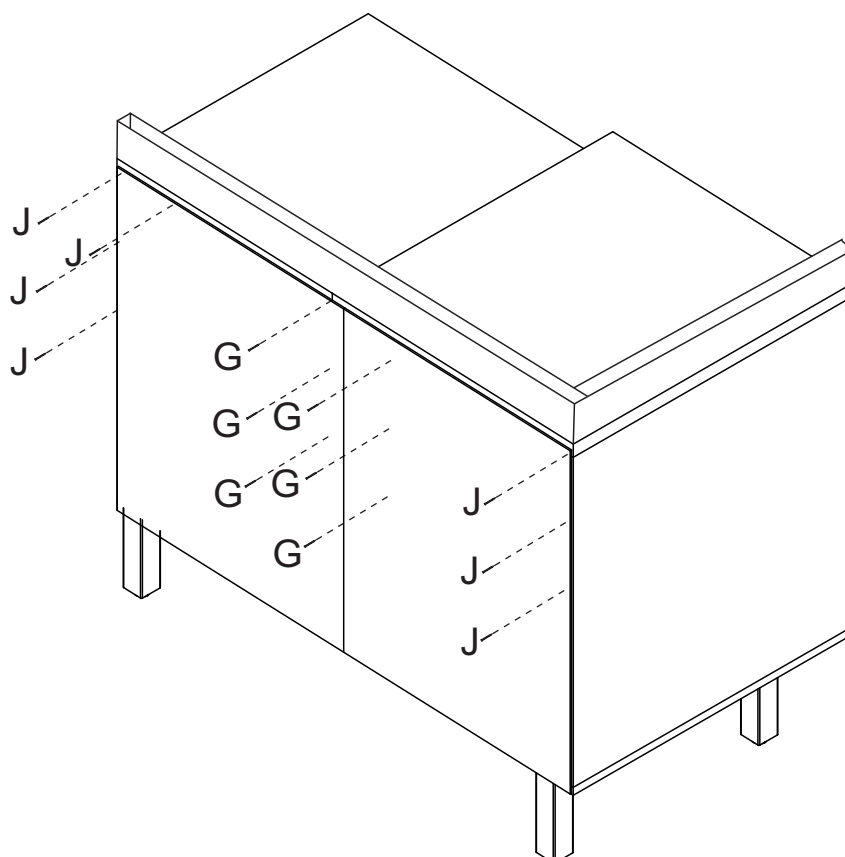

08

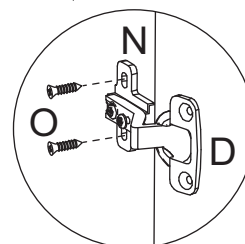
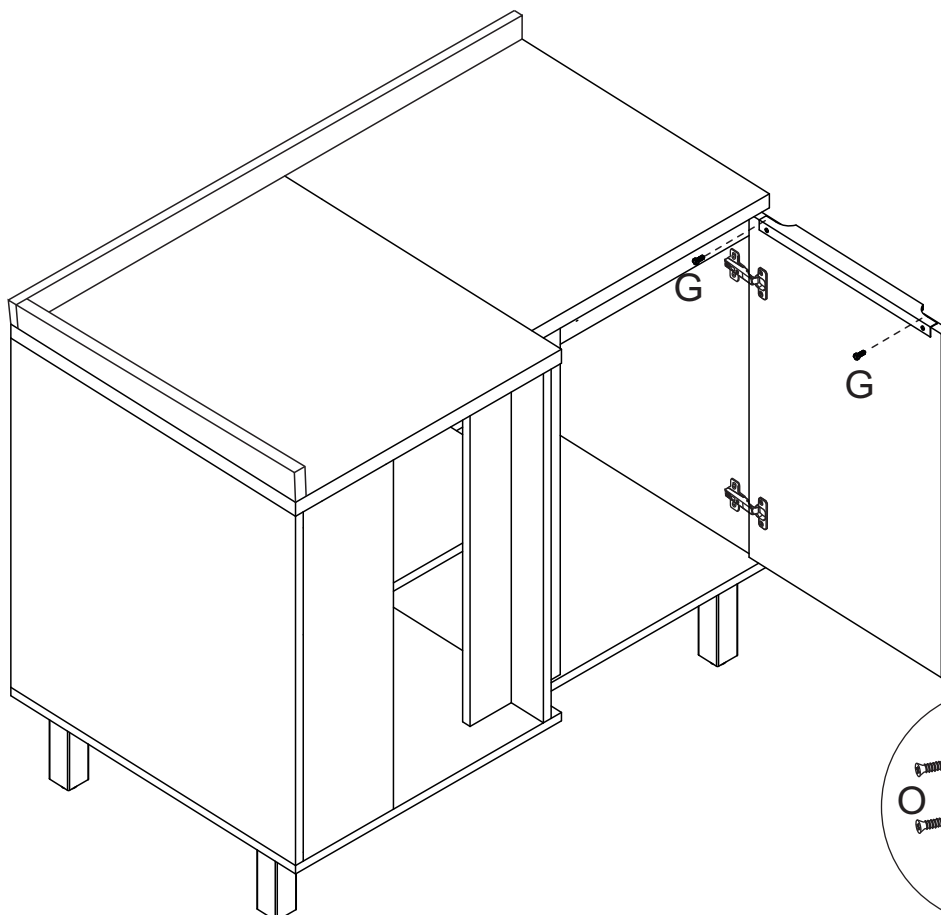

Limpeza/Limpieza

- ≠ Use um pano levemente umedecido com água, seguido de pano seco.
- ≠ Use solamente un paño húmedo con agua y después un paño seco.
- ≠ Nunca utilize produtos químicos ou abrasivos.
- ≠ No utilice productos químicos o abrasivos.

mx

mxmóveis

Rodovia SC-492 - Km 10 - B. Industrial
89905-000 - Bandeirante - SC

Fone: (49) 3622-4549

e-mail: mxmoveis@mxmoveis.com.br

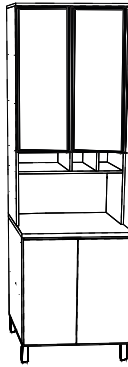

Ref. PTO01

Paneleiro Cozinha/Cocina TOSCANA

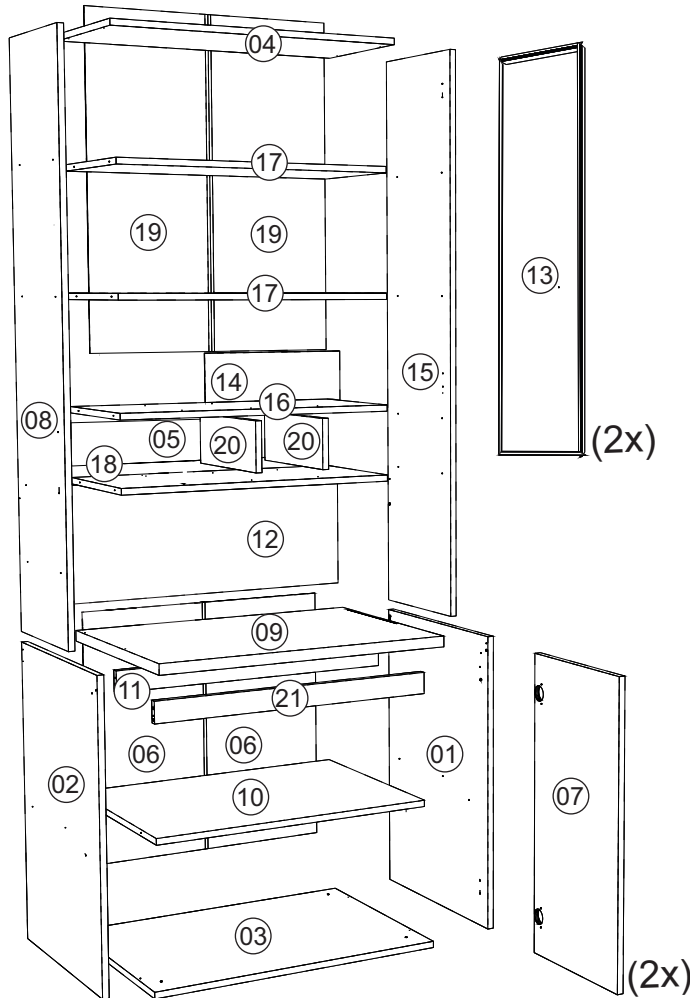



Nº	CÓDIGO ASSISTÊNCIA	NOME DA PEÇA/DESCRIPCIÓN PIEZAS	MEDIDAS (mm)	QTD.	CÓDIGO DAS PEÇAS/ CÓDIGO PIEZAS		
					FREIJÓ/FREIJO	FREIJÓ/NERO	FREIJÓ/JADE
01	PTO01.17.00	Lateral externa direita/Lateral derecha	710x496x15	01	209162	209162	209162
02	PTO01.18.00	Lateral externa esquerda/Lateral izquierda	710x496x15	01	209163	209163	209163
03	PTO01.01.00	Base inferior/Base inferior	700x516x15	01	209161	209161	209161
04	PTO01.05.00	Base superior/Base superior	700x290x15	01	209175	209175	209175
05	PTO01.40.00	Painel	690x135x6	01	209171	209171	209171
06	PTO01.13.00	Forro/Revés	687x342x2.5	02	209167	209167	209167
07	PTO01.25.00	Porta/Puerta	702x339x15	02	209154	209250	209246
08	PTO01.18.01	Lateral externa esquerda/Lateral izquierda	1365x270x15	01	209170	209170	209170
09	PTO01.33.00	Tampo	700x516x22	01	209168	209168	209168
10	PTO01.02.02	Base interna	670x496x15	01	210471	210471	210471
11	PTO01.28.01	Ripa sustentação	670x50x15	01	209166	209166	209166
12	PTO01.13.03	Forro/Revés	690x360x2.5	01	209178	209178	209178
13	5269	Porta/Puerta	2089x339x20	02			
14	PTO01.13.01	Forro/Revés	684x164x2.5	01	209176	209176	209176
15	PTO01.17.01	Lateral externa direita/Lateral direita	1365x270x15	01	209169	209169	209169
16	PTO01.02.00	Base interna	670x270x15	01	209173	209173	209173
17	PTO01.02.01	Base interna	670x270x15	02	209174	209174	209174
18	PTO01.02.04	Base Interna	670x270x15	01	209179	209179	209179
19	PTO01.13.02	Forro/Revés	889x342x2.5	02	209177	209177	209177
20	PTO01.19.00	Lateral interna menor	270x120x15	02	209172	209172	209172
21	PTO01.28.00	Ripa sustentação	670x50x15	01	209165	209165	209165

Ferragens/Herrajes

A  **14x**
Cavilha Ø6,0x30mm Cód. 873

B  **44x**
Parafuso 3,5x40mm Cht. Cód. 691

C  **08x**
Parafuso 4,0x14mm Cht. Cód. 667

D  **04x**
Puxador / Manija Cód. 5137

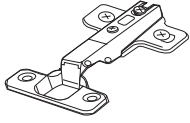
E  **08x**
Dobradiça Cód. 5491

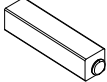
F  **05x**
Pé plástico Cód. 5883

G  **05x**
Parafuso 5,0x50mm Cht. Cód. 1979

H  **08x**
Parafuso 3,5x25mm Cht. Cód. 692

I  **01x**
Perfil 889mm Cód. 9820

J  **32x**
Parafuso 4,0x12mm Cht. Cód. 7604

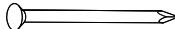
K  **136x**
Prego 8x8 Cód. 822

L  **01x**
Perfil 687mm Cód. 9819

M  **01x**
Bisnaga cola Cód. 8255

N  **4x**
Cantoneira metálica Cód. 7168



O  **14x**
Parafuso 3,0x12mm Cht. Cód. 11413



P  **06x**
Parafuso 4,0x50mm Cht. Cód. 12537

Q  **08x**
Fixador costa Cód. 7169

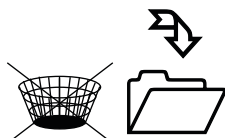
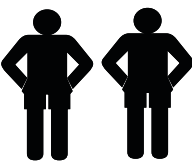

Medidas em mm

 *Usar os parafusos (G) para unir este módulo a outro. Usar los tornillos (G) para unirse este módulo a otro. 

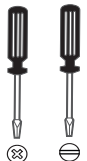
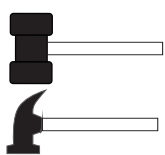
		 1:00		
---	---	---	---	---

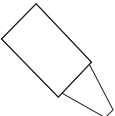
 Giz para madeira	<i>Produto para ser aplicado em caso de riscos na superfície</i>
---	--

Pré-Montagem/Preparación Piezas



Utilizar
cola nas
cavilhas.

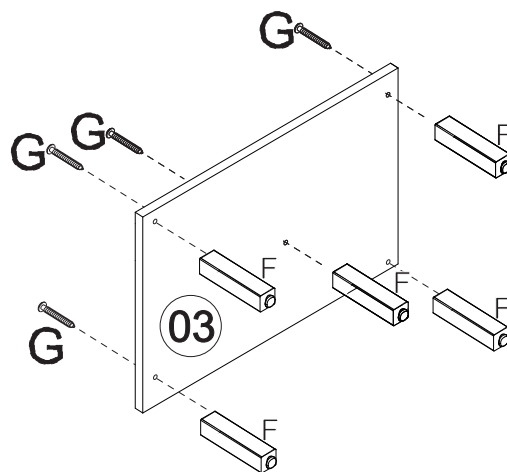
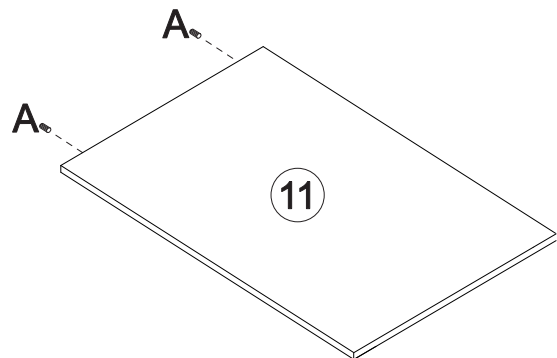
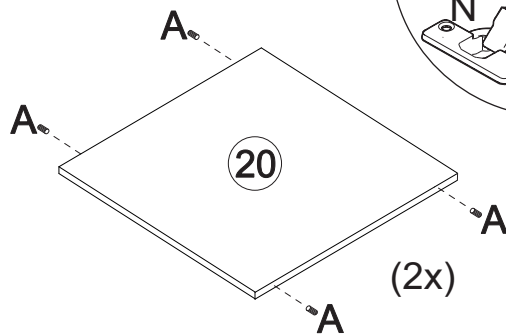
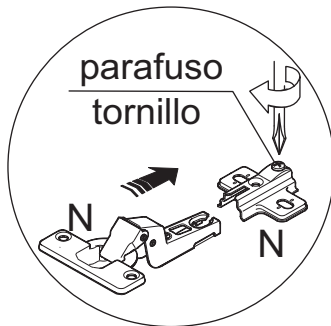
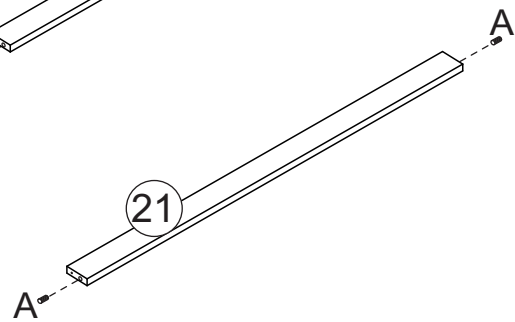
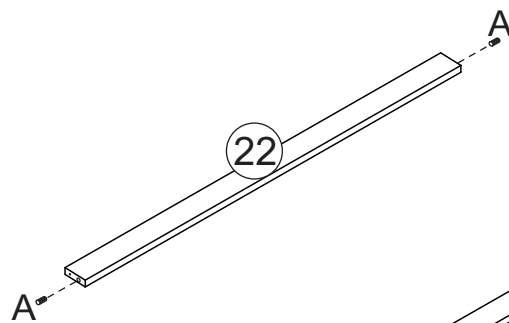
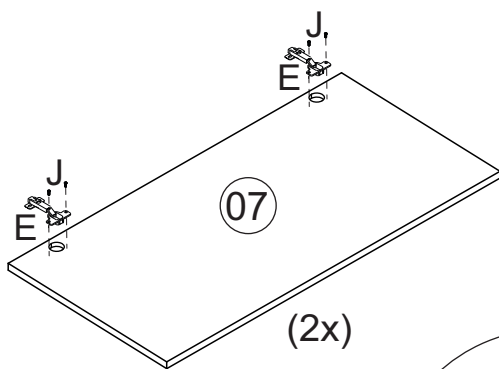
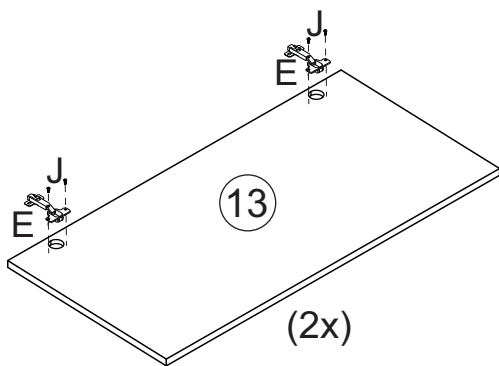

01 Montagem/Montaje

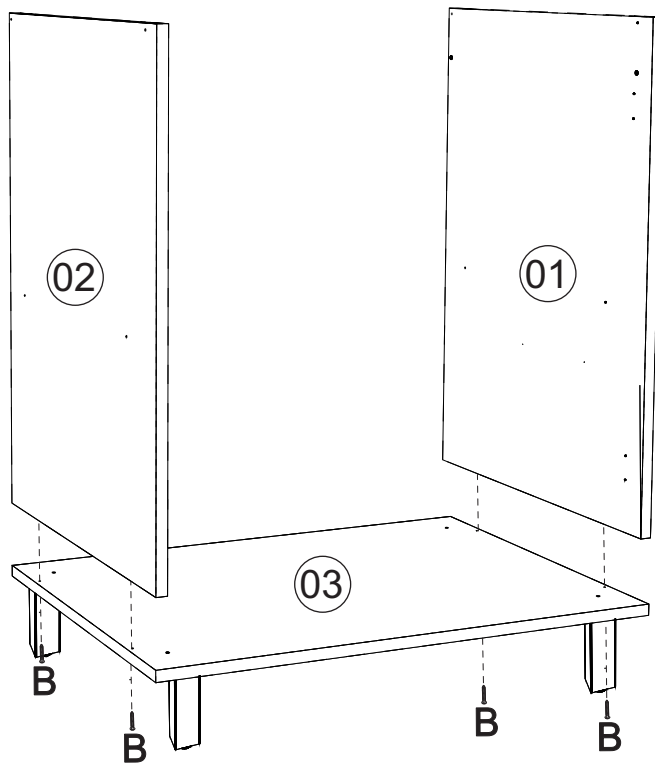

02 Montagem/Montaje

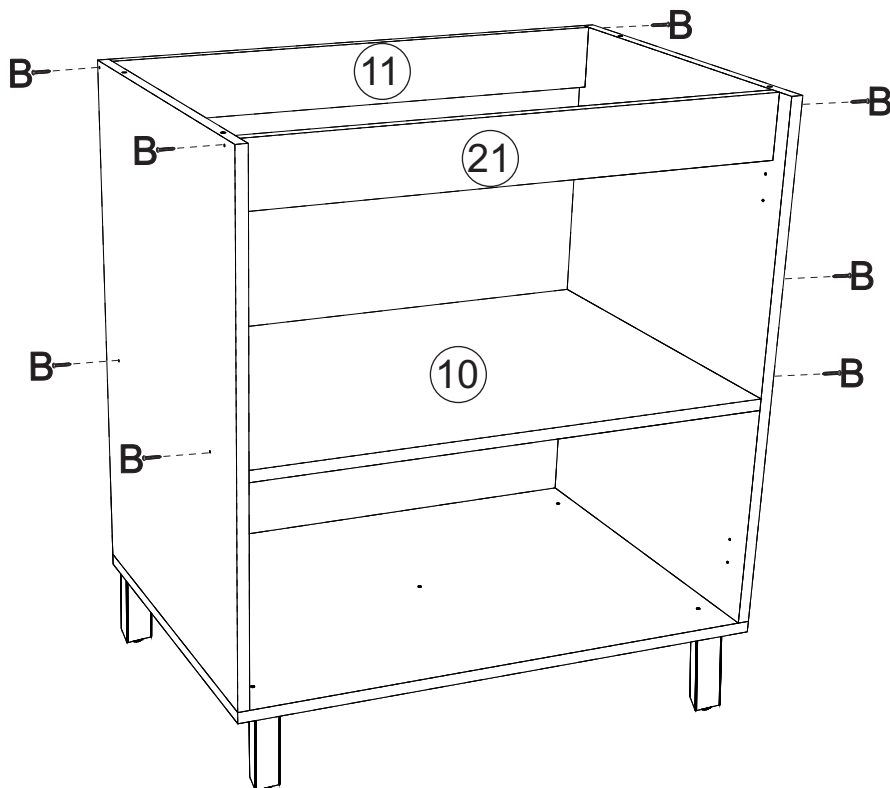

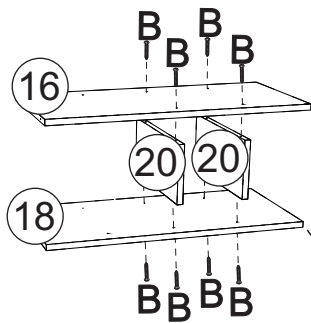
03**Montagem/Montaje**

Tomada USB deve ser encaixada no painel

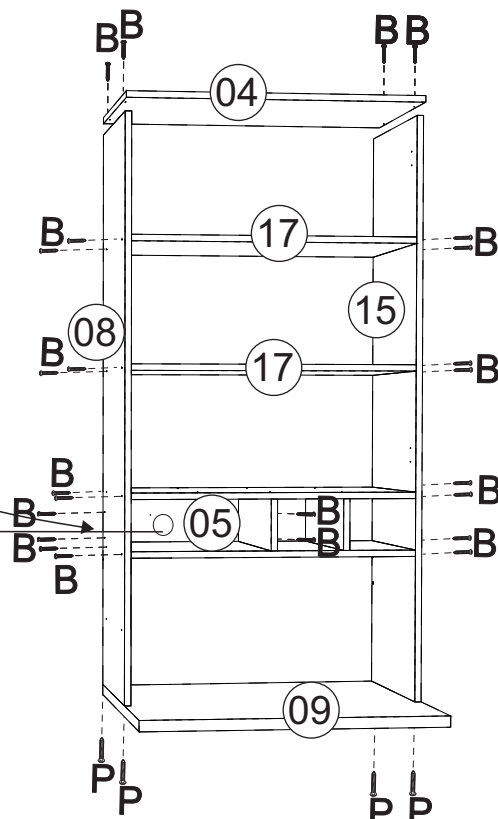

Obs: São utilizados 4 parafusos 4,0x50 para melhor fixação do paneleiro

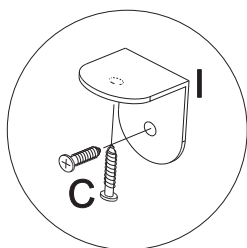
04**Montagem/Montaje**

Obs: são utilizados 4 cantoneira para fixação do tampo.

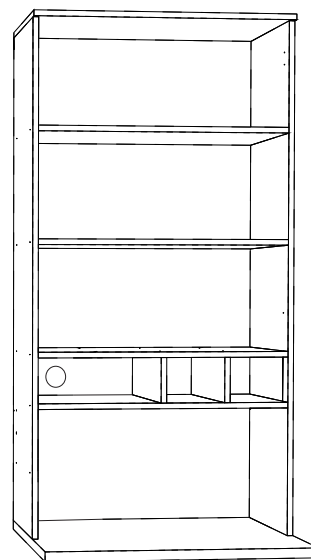
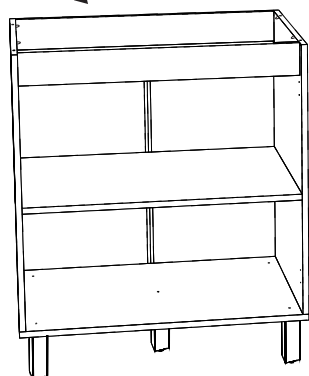

07

Montagem/Montaje

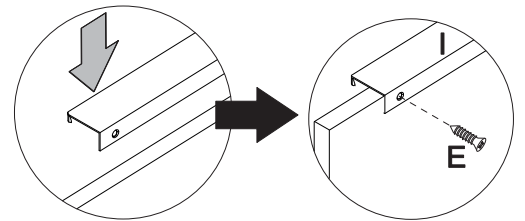
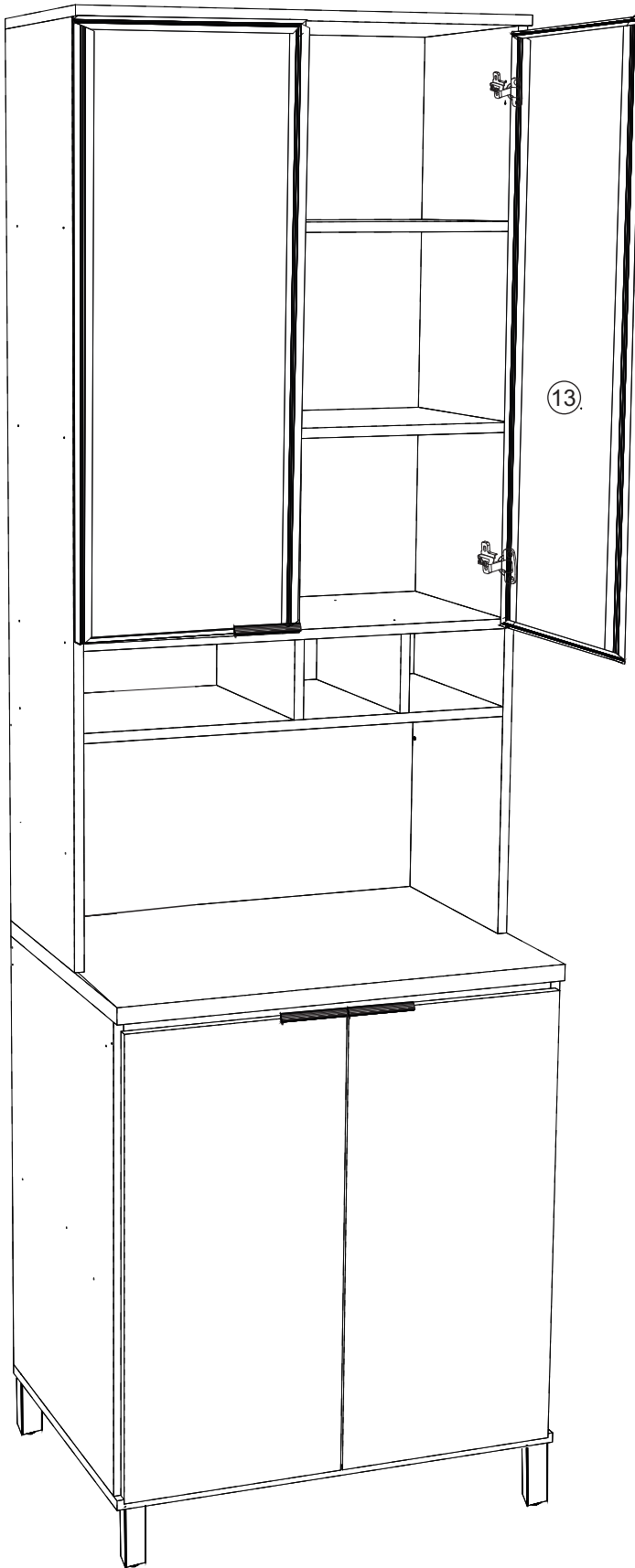

Limpeza/Limpieza

- ✍ Use um pano levemente umedecido com água, seguido de pano seco.
- ✍ *Use solamente un paño húmedo con agua y después un paño seco.*
- ✍ Nunca utilize produtos químicos ou abrasivos.
- ✍ *No utilice productos quimicos o abrasivos.*