

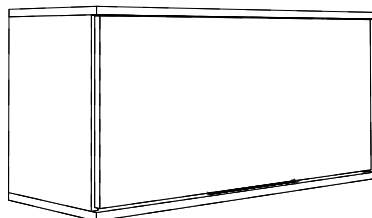

Rodovia SC-492 - Km 10 - B. Industrial
89905-000 - Bandeirante - SC
Fone: (49) 3622-4549
e-mail: mxmoveis@mxmoveis.com.br



Ref. ATO02

Aéreo 800 Basc
Armario 800
Cozinha/Cocina
Toscana

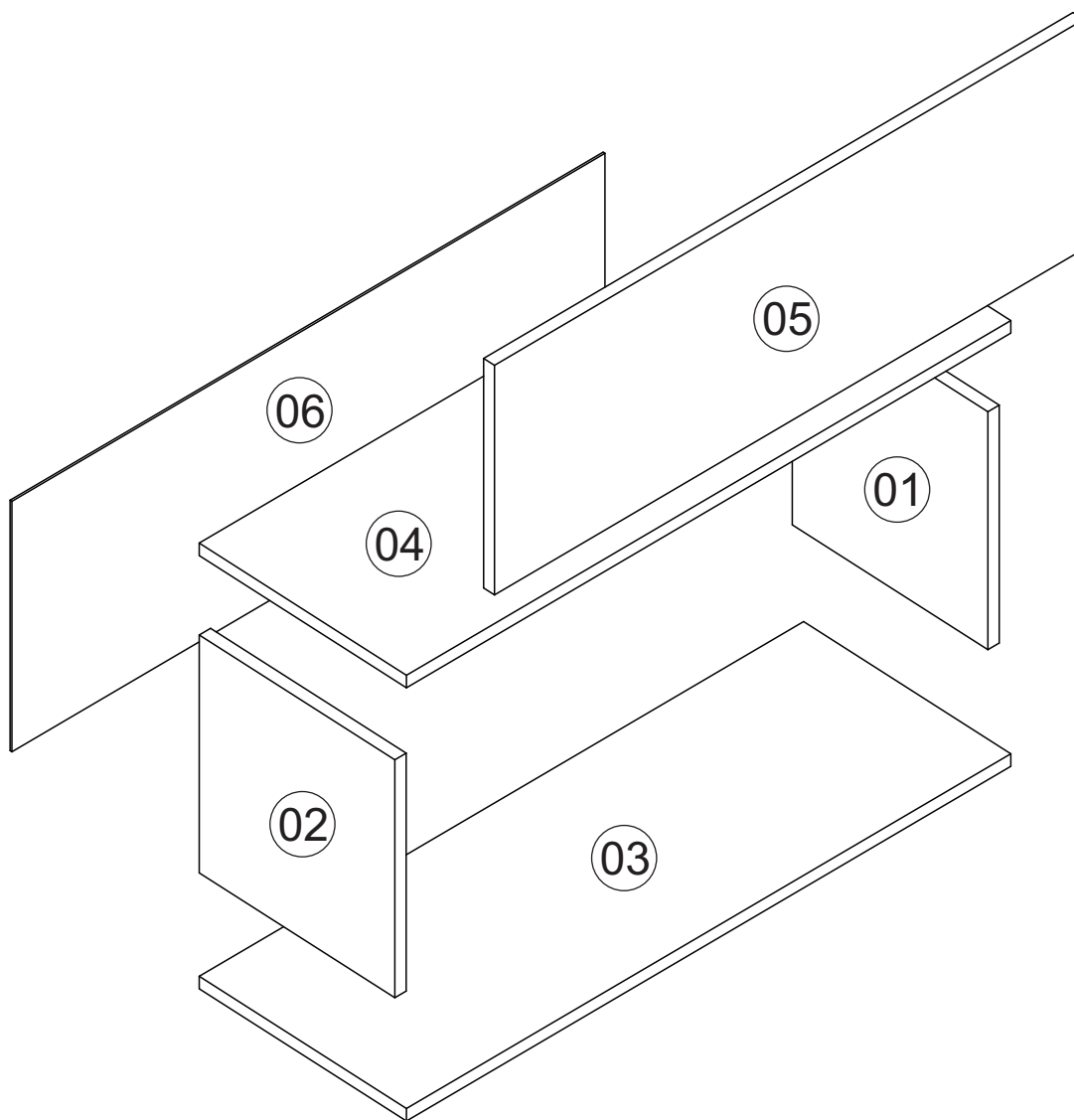

Nº	CÓDIGO ASSISTÊNCIA	NOME DA PEÇA/DESCRIPCIÓN PIEZAS	MEDIDAS (mm)	QTD.	CÓDIGO DAS PEÇAS/ CÓDIGO PIEZAS
					FREIJÓ/FREIJÓ
01	ATO02.17.01	Lateral externa direita/Lateral derecha	340x270x15	01	209897
02	ATO02.18.01	Lateral externa esquerda/Lateral izquierda	340x270x15	01	209898
03	ATO02.01.01	Base inferior/Base inferior	800x290x15	01	208663
04	ATO02.05.01	Base superior/Base superior	800x290x15	01	208664
05	ATO02.25.01	Porta/Puerta	780x332x15	01	209889
06	ATO02.13.01	Forro/Revés	790x360x2.5	01	209899

Ferragens/Herrajes

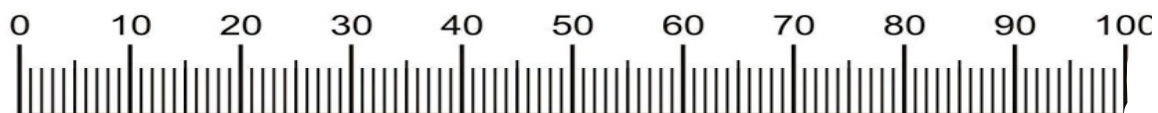
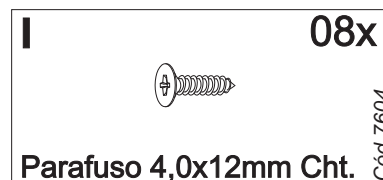
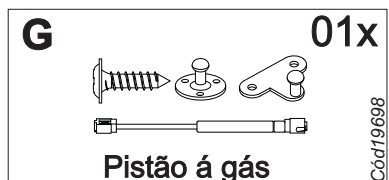
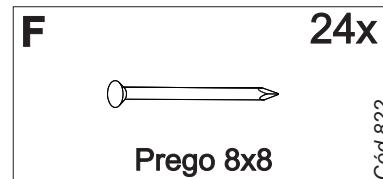
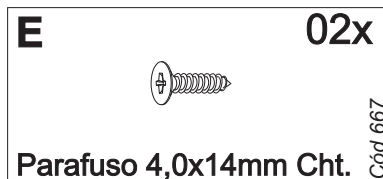
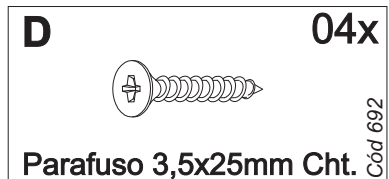
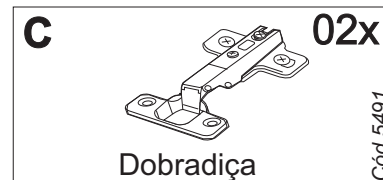
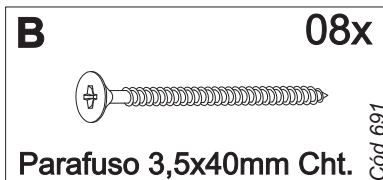
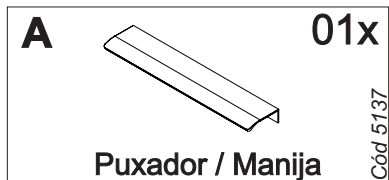

Medidas em mm

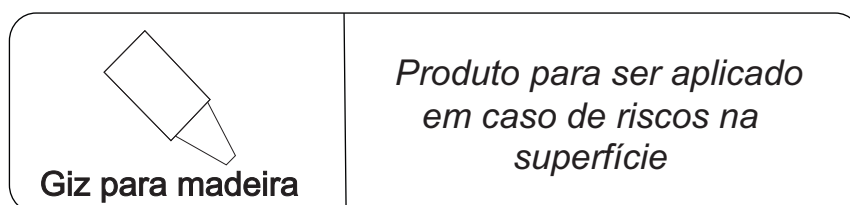
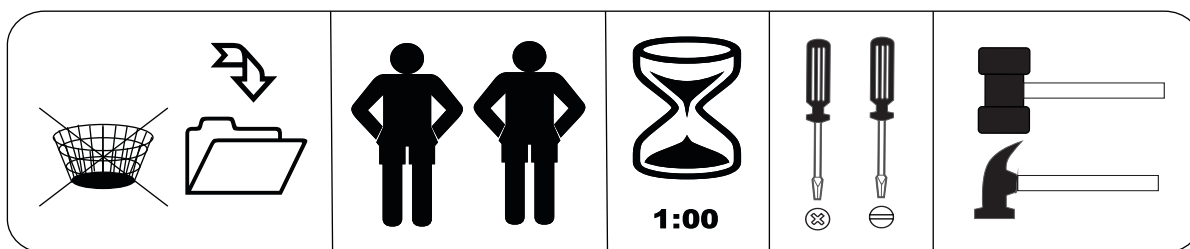

01 → Montagem/Montaje

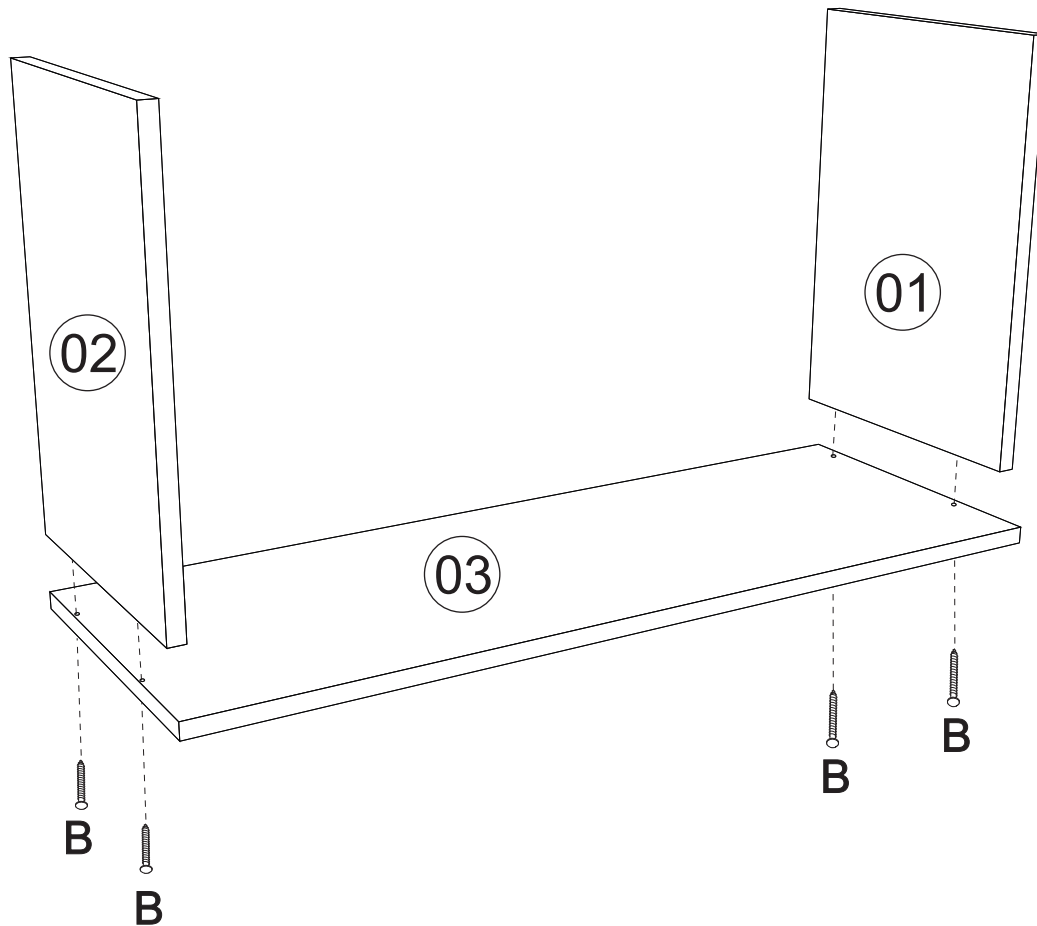

02 → Montagem/Montaje

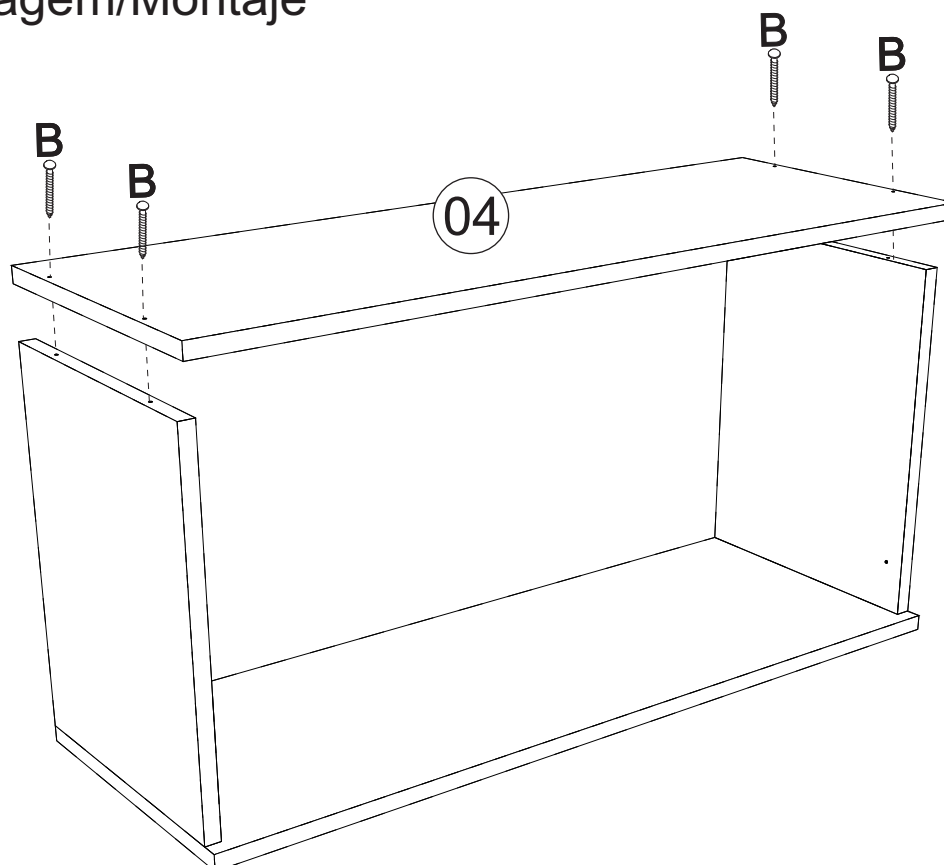

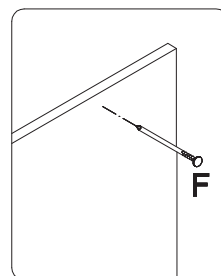
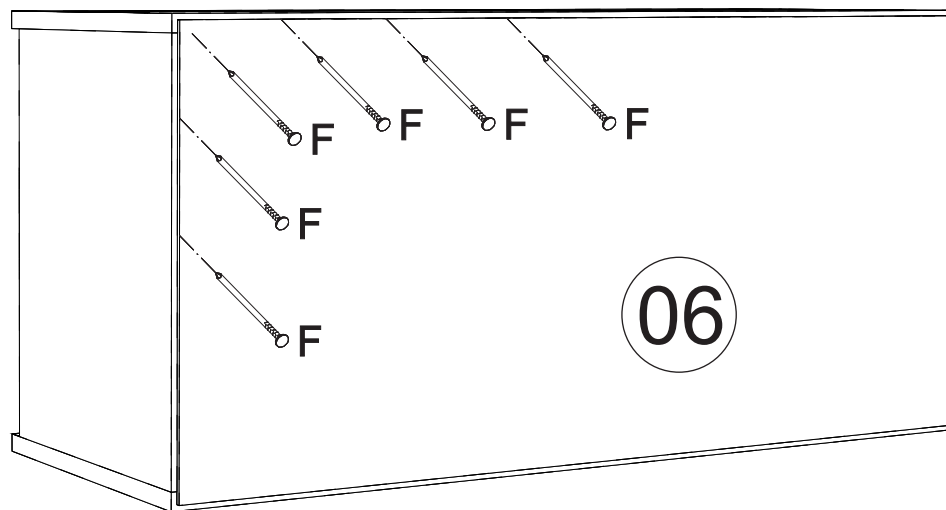
03**Montagem/Montaje**

*Colocar um prego (F)
a cada 100mm

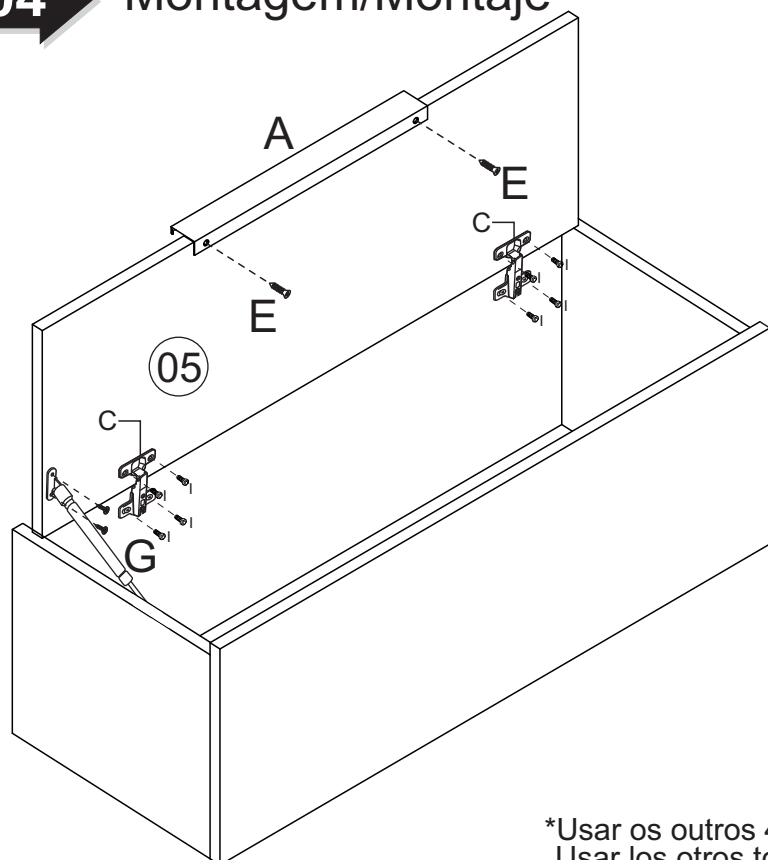
04**Montagem/Montaje**

Fixação na parede
Fijación en la pared

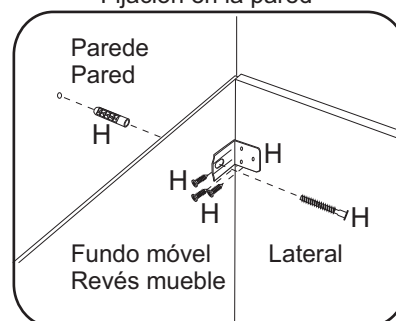

*Fixar a cantoneira na parte interna do móvel.
Fijar la pieza «H» en el interior del mueble.

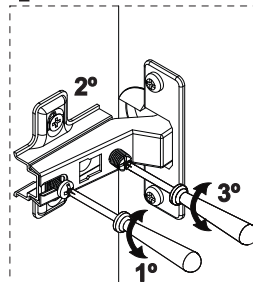
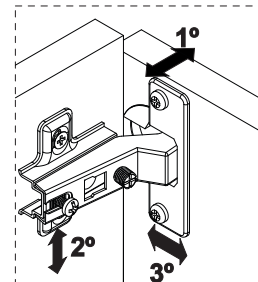
1º**2º**

*Usar os outros 4 parafusos (D) para unir este módulo a outro.
Usar los otros tornillos (D) para unirse este modulo a otro.



Rodovia SC-492 - Km 10 - B. Industrial
89905-000 - Bandeirante - SC
Fone: (49) 3622-4549
e-mail: mxmoveis@mxmoveis.com.br

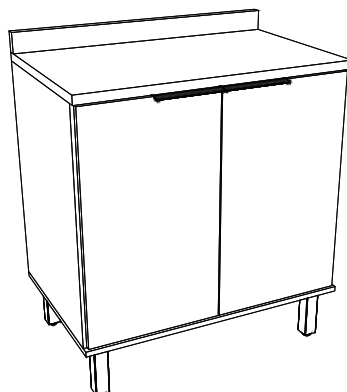

Ref. BTO02

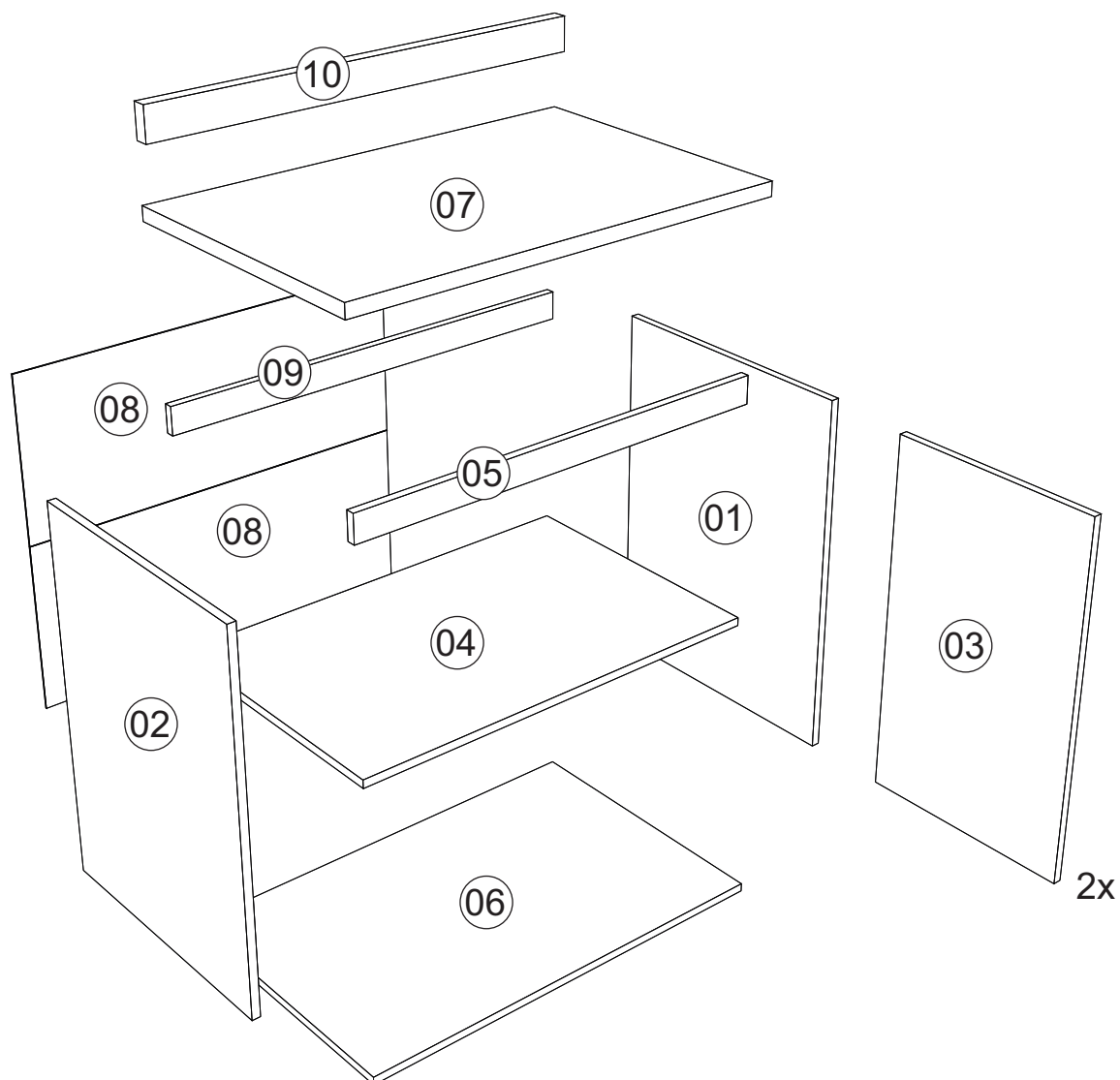

Balcão 800
Cozinha/Cocina
TOSCANA

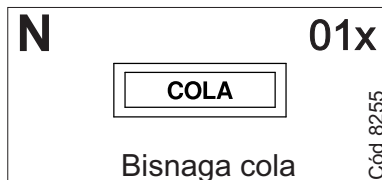
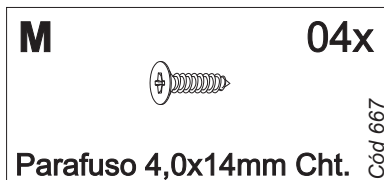
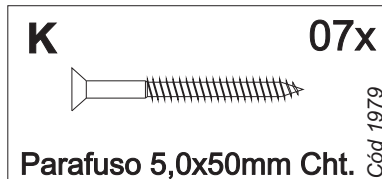
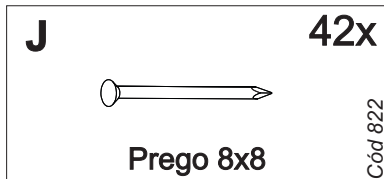
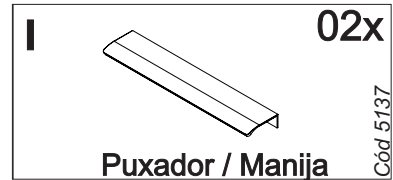
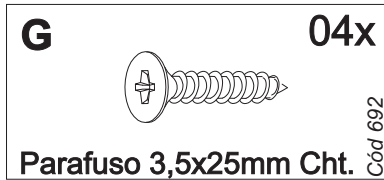
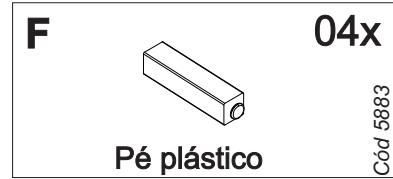
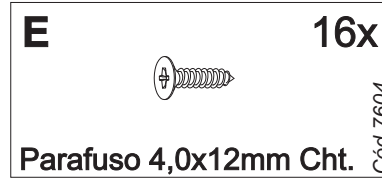
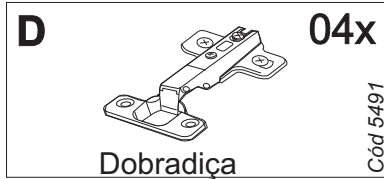
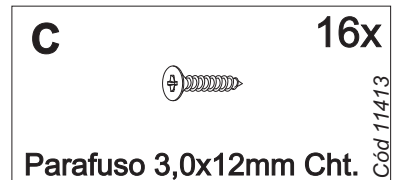
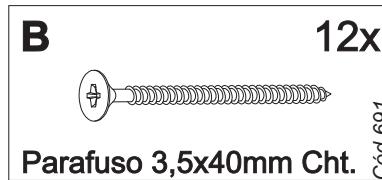
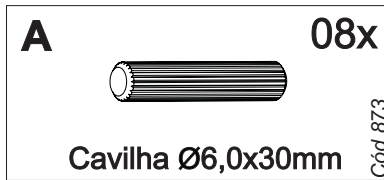

Nº	CÓDIGO ASSISTÊNCIA	NOME DA PEÇA/DESCRIPCIÓN PIEZAS	MEDIDAS (mm)	QTD.	CÓDIGO DAS PEÇAS		
					FREIJO/FREIJO	FREIJO/NERO	FREIJO/JADE
01	BTO02.17.00	Lateral externa direita/Lateral derecha	710x496x15	01	208841	208841	208841
02	BTO02.18.00	Lateral externa esquerda/Lateral izquierda	710x496x15	01	208842	208842	208842
03	BTO02.25.00	Porta balcão/Puerta	702x389x15	02	208878	208967	208959
04	BTO02.02.00	Base interna/Base pequena	770x450x15	01	208843	208843	208843
05	BTO02.28.00	Ripa balcão frontal/Travesaño	770x50x15	01	208846	208846	208846
06	BTO02.01.02	Base inferior/Base inferior	800x516x15	01	208849	208849	208849
07	BTO02.33.01	Tampo balcão/Tapa	800x516x22	01	208848	208848	208848
08	BTO02.13.00	Forro/Revés	790x336x2.5	02	208844	208844	208844
09	BTO02.28.01	Ripa balcão traseira/Travesaño	770x50x15	01	208845	208845	208845
10	BTO02.51.00	Roda tampo/Rueda Superior	800x60x22	01	208847	208847	208847

Ferragens/Herrajes



 *Usar os parafusos (G) para unir este módulo a outro.  Usar los tornillos (G) para unirse este módulo a otro.



Medidas em mm

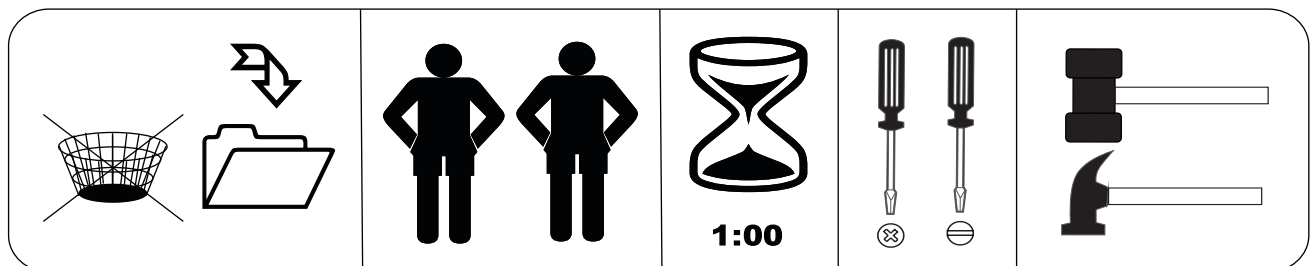

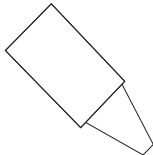
 **Giz para madeira**

Produto para ser aplicado em caso de riscos na superfície

Pré-Montagem/Preparación Piezas

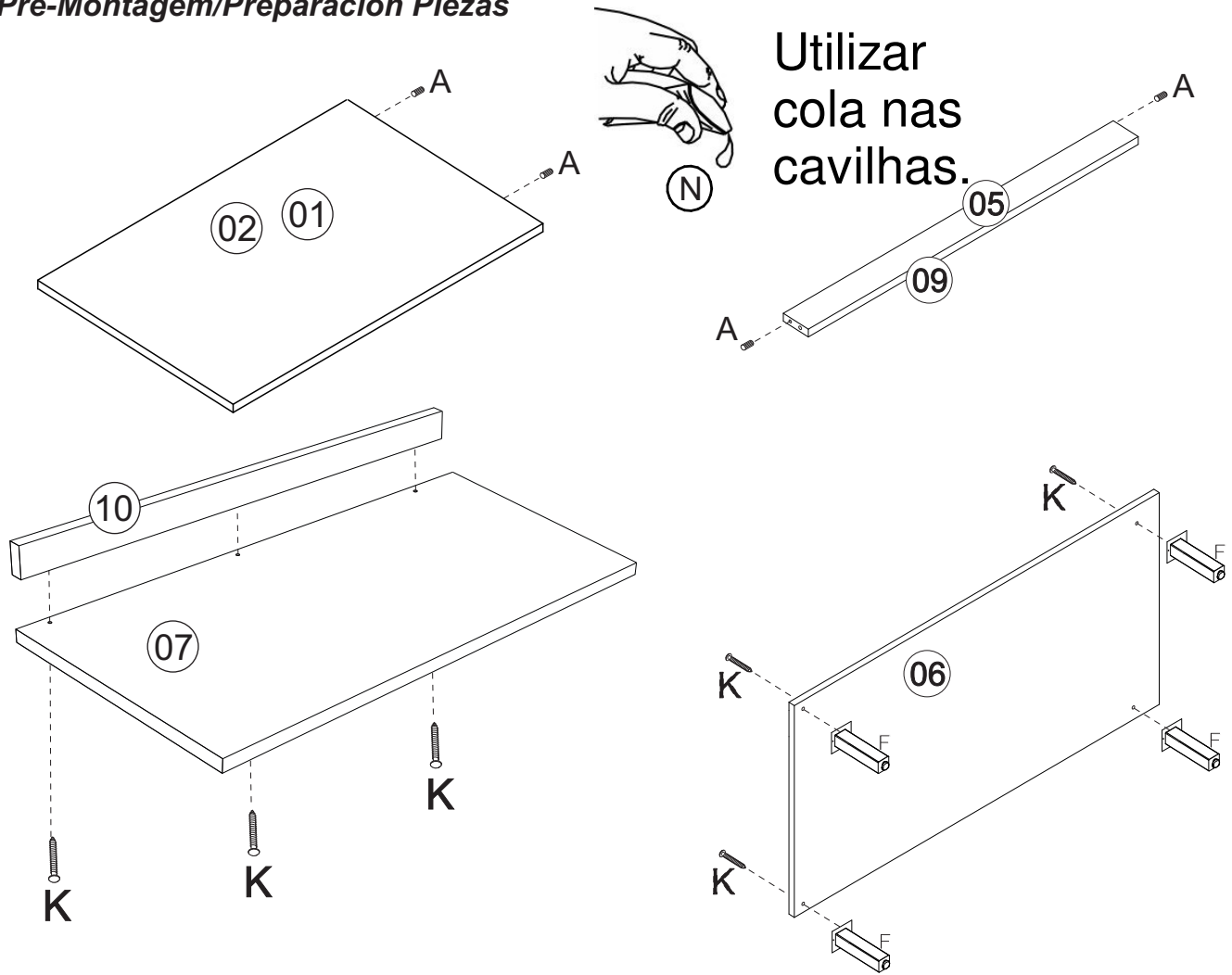

01 Montagem/Montaje

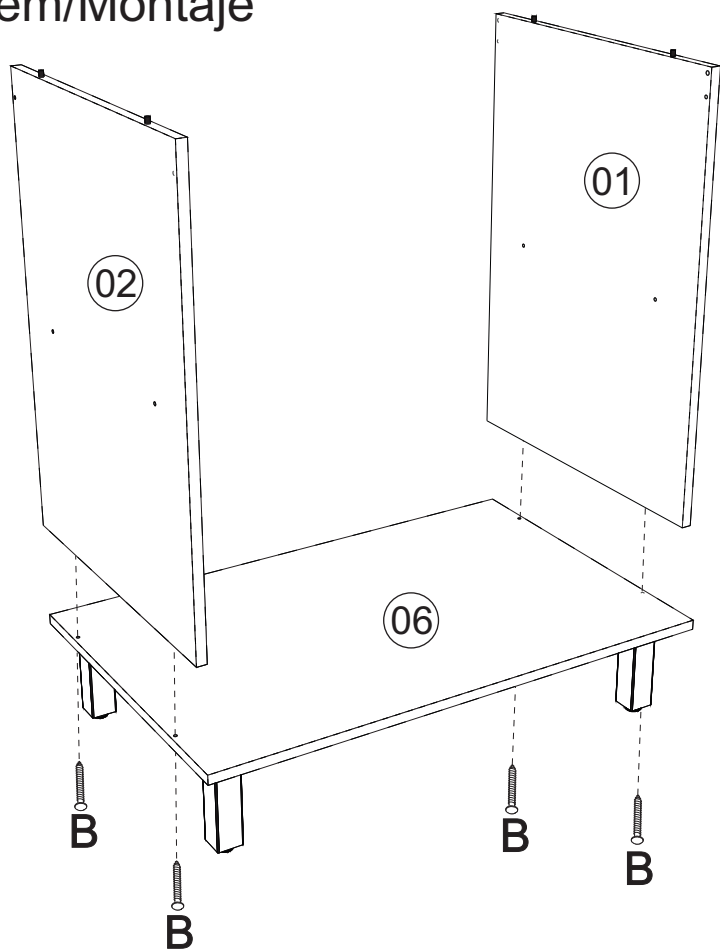

02 Montagem/Montaje

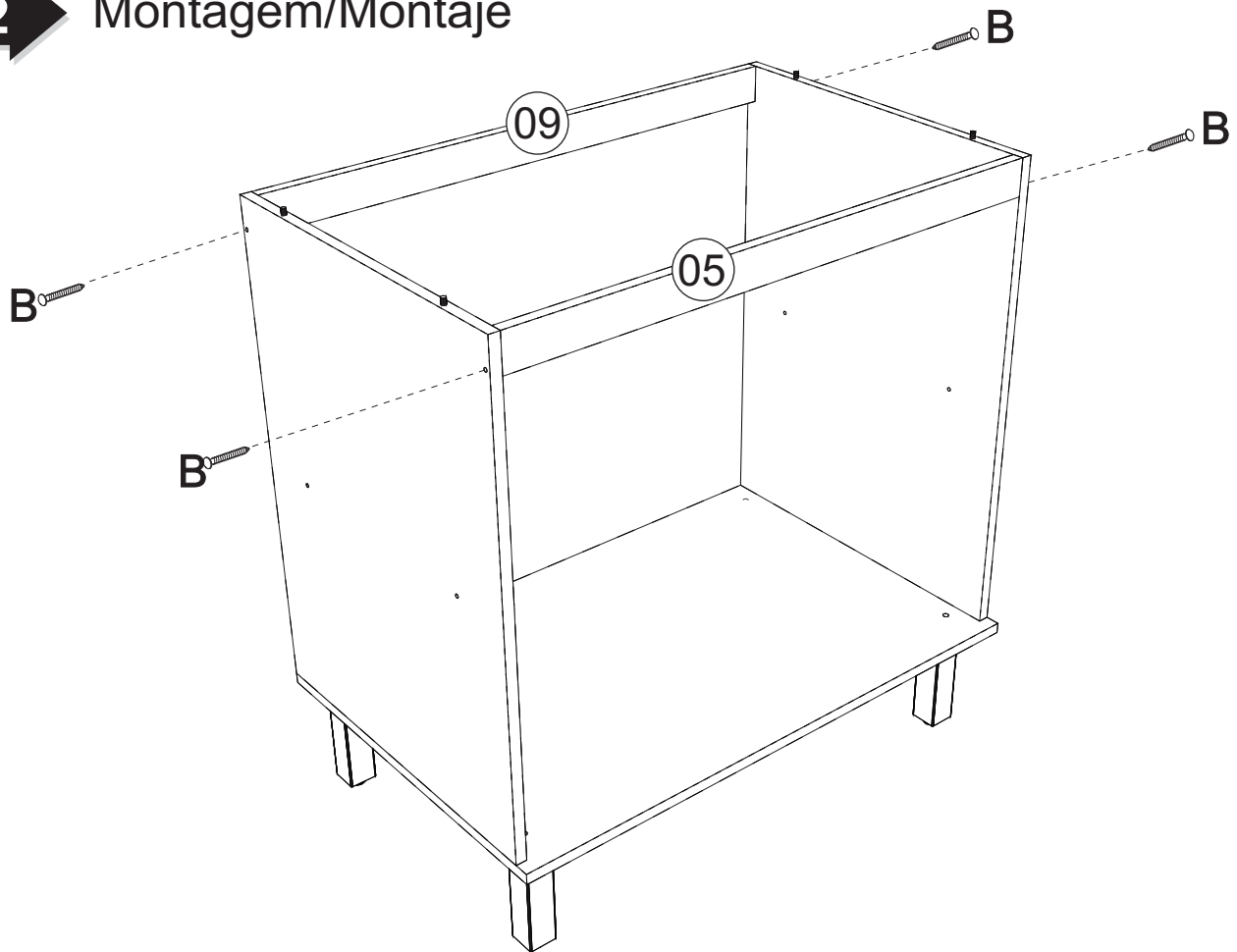

03 Montagem/Montaje

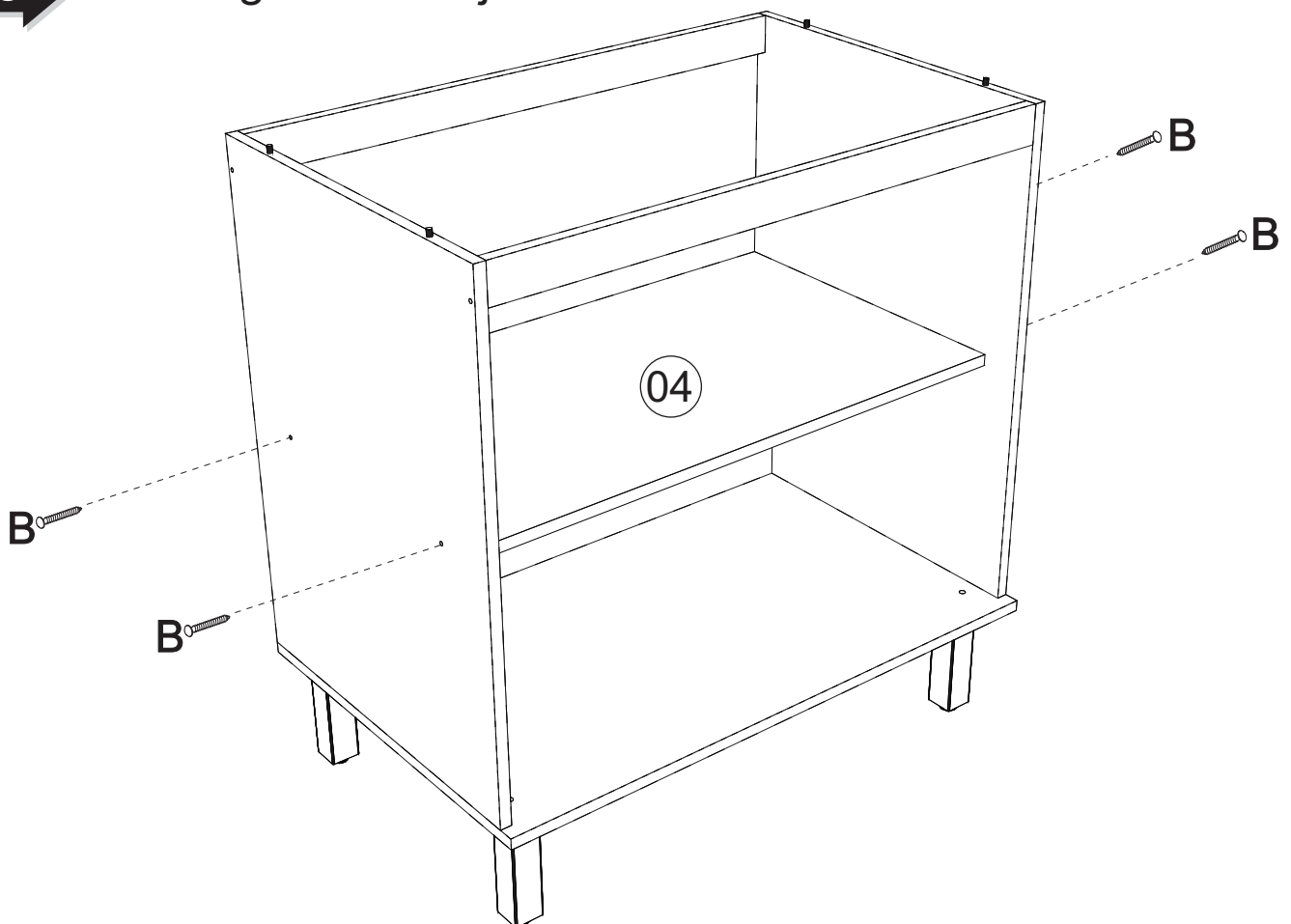

04 Montagem/Montaje

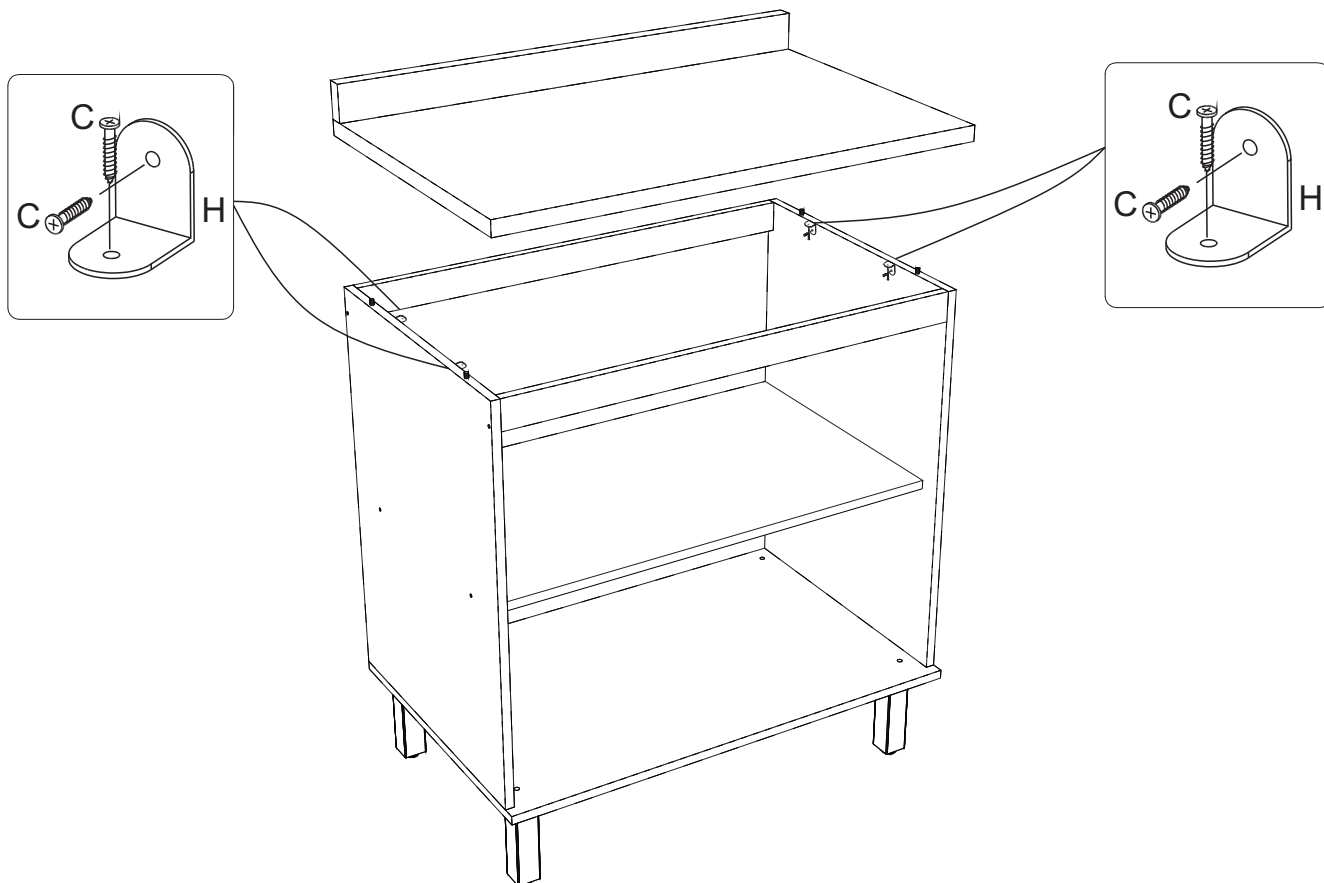

05 Montagem/Montaje

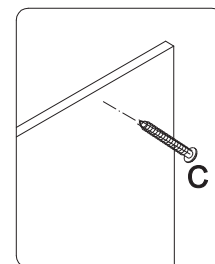
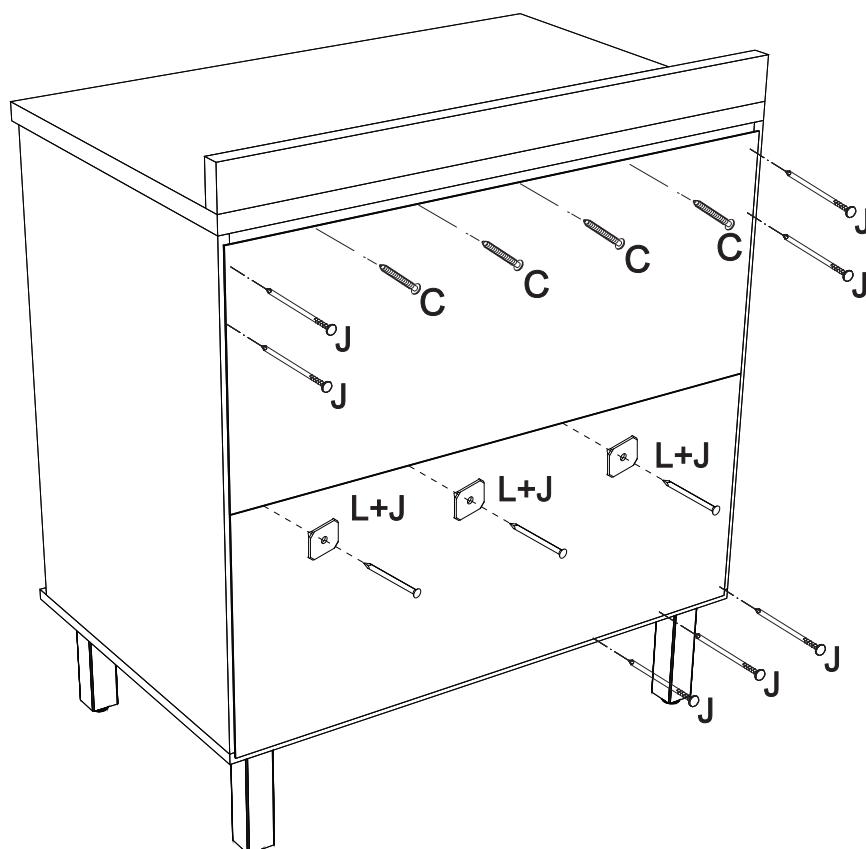

*Colocar um parafuso (C) a cada 100mm

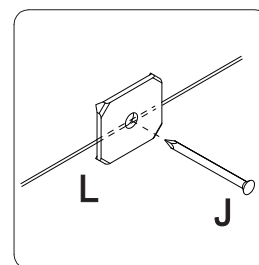

*Colocar o prego (J) e a junção (L) a cada 100mm

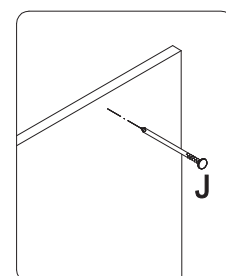

*Colocar um prego (J) a cada 100mm

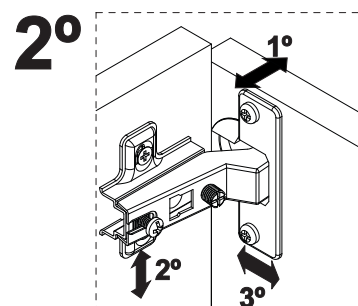
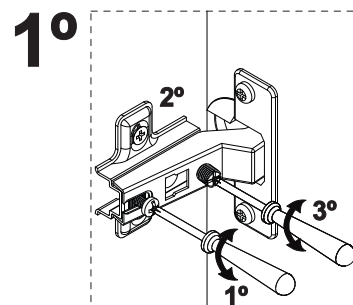
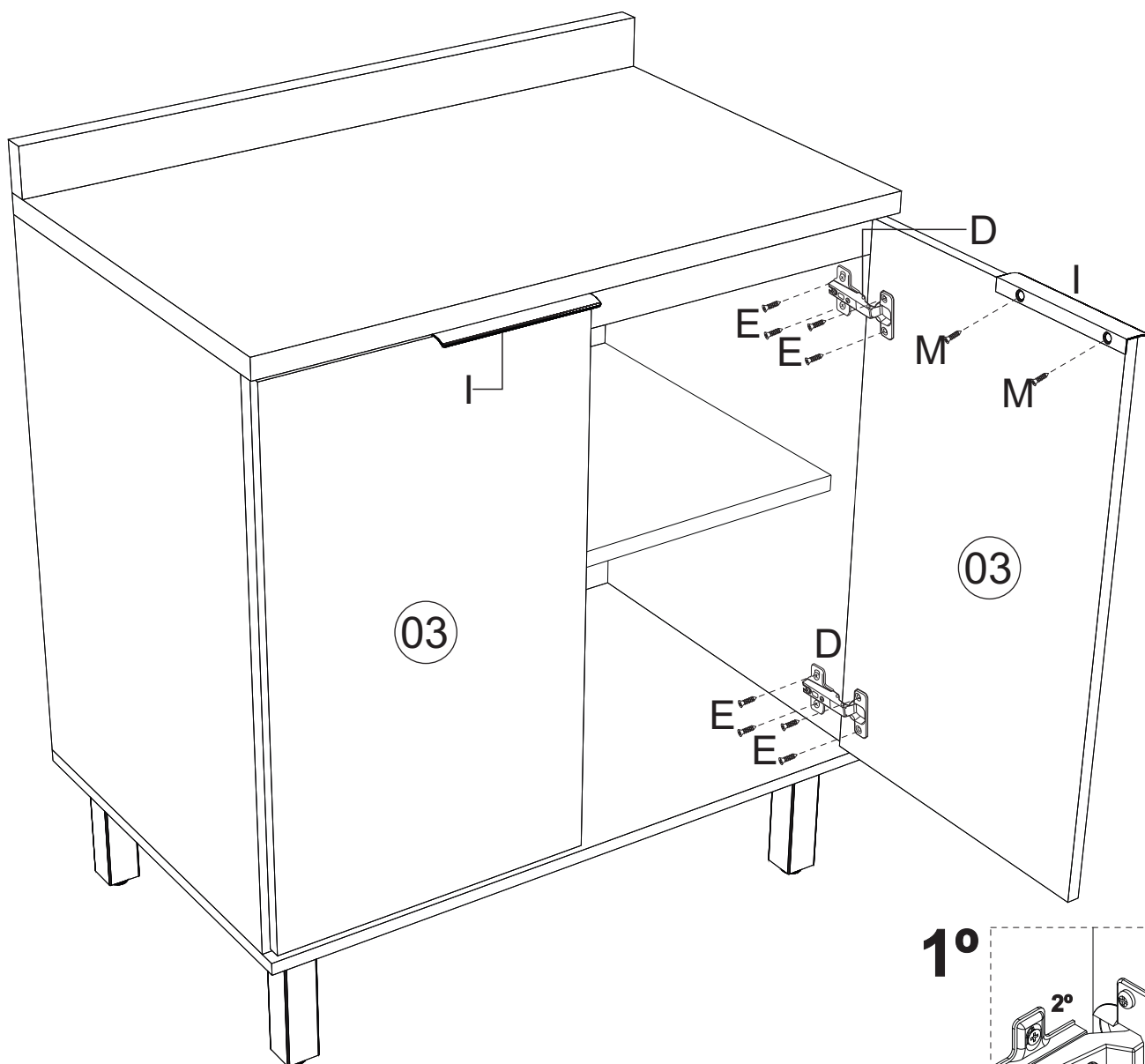
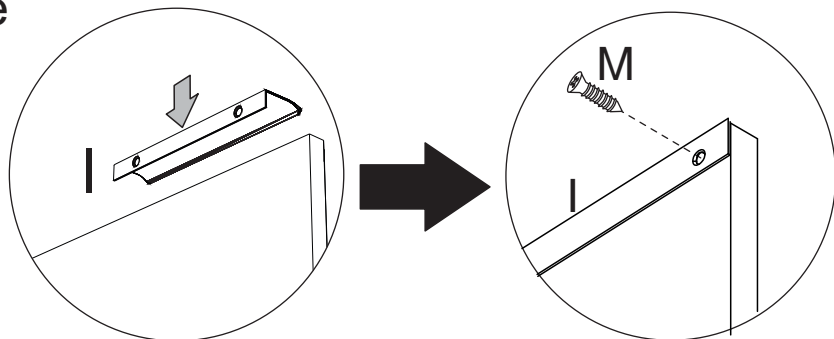
06**Montagem/Montaje****Limpeza/Limpieza**

- ⚠ Use um pano levemente umedecido com água, seguido de pano seco.
- ⚠ Use solamente un paño húmedo con agua y después un paño seco.
- ⚠ Nunca utilize produtos químicos ou abrasivos.
- ⚠ No utilice productos químicos o abrasivos.



mxmóveis

Rodovia SC-492 - Km 10 - B. Industrial
89905-000 - Bandeirante - SC
Fone: (49) 3622-4549
e-mail: mxmoveis@mxmoveis.com.br

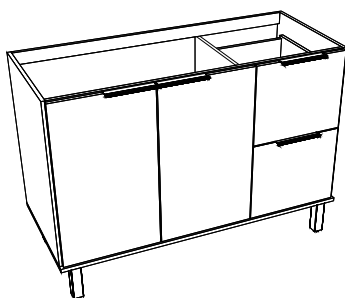

Ref. BTO03

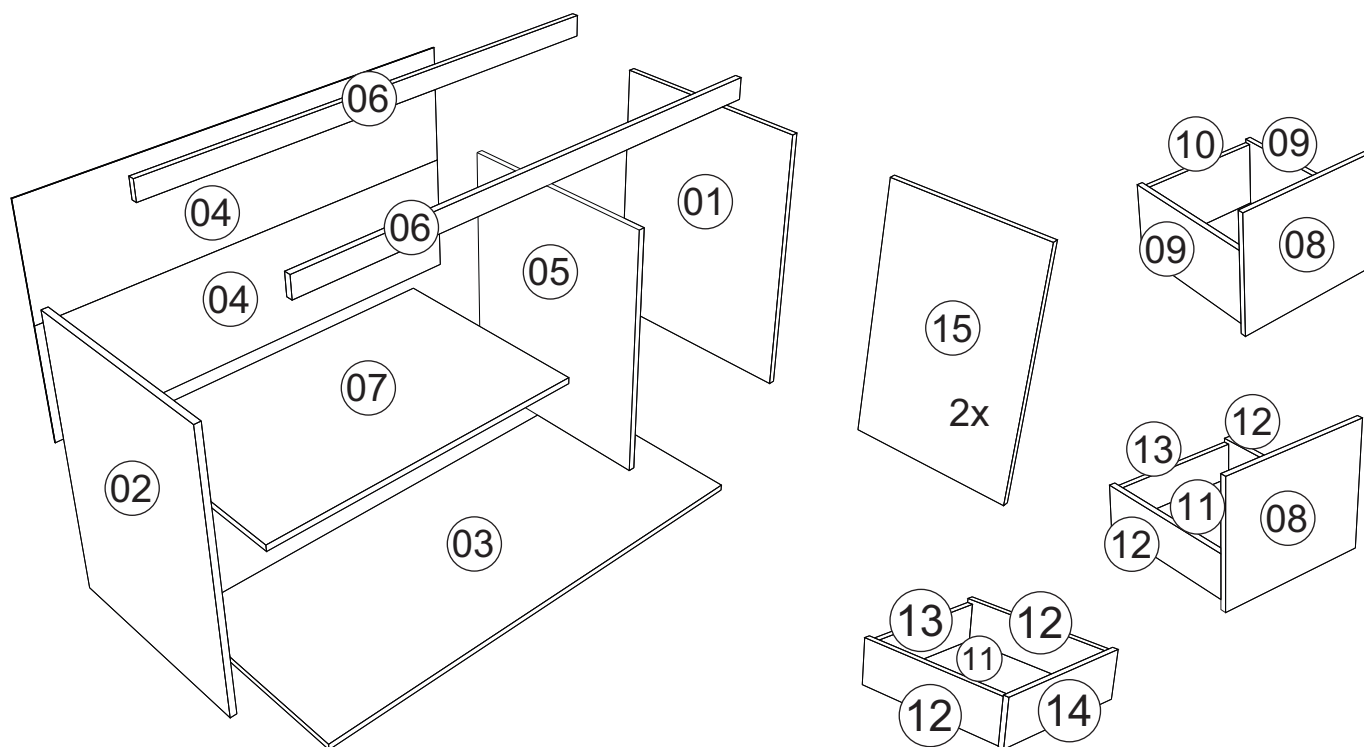

Balcão 1200 2P 3G
Cozinha/Cocina
TOSCANA



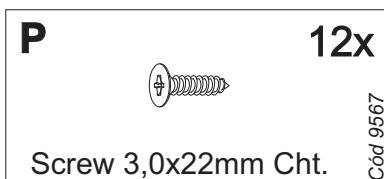
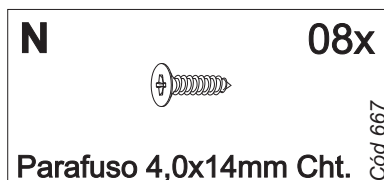
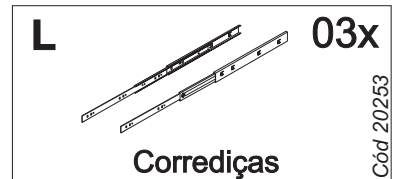
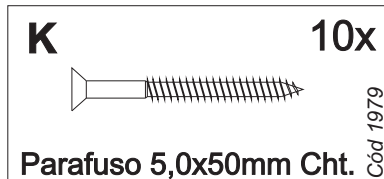
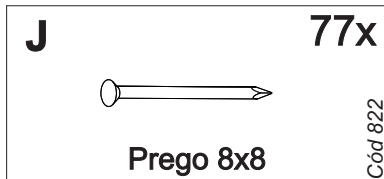
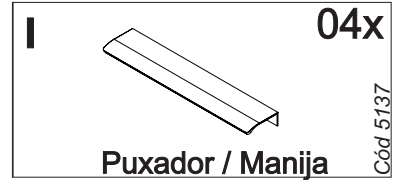
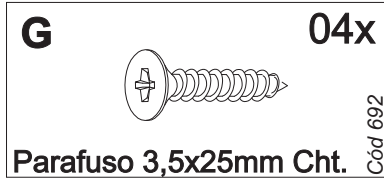
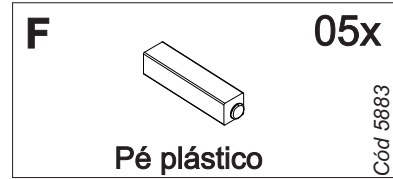
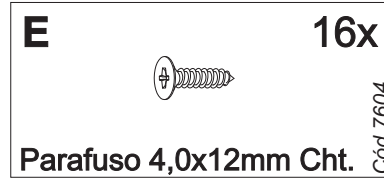
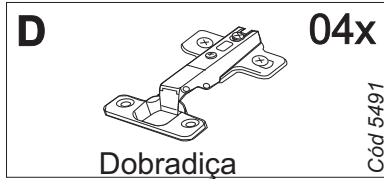
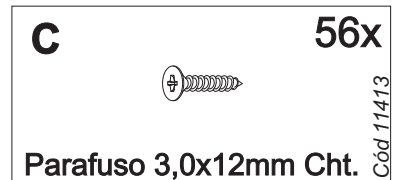
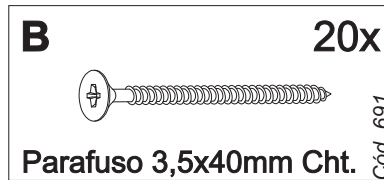
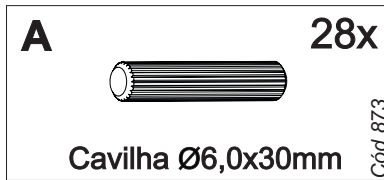

Nº	CÓDIGO ASSISTÊNCIA	NOME DA PEÇA/DESCRIPCIÓN PIEZAS	MEDIDAS (mm)	QTD	CÓDIGO DAS PEÇAS/ CÓDIGO PIEZAS		
					FREIJÓ/FREIJÓ	FREIJÓ/NERO	FREIJÓ/JADE
01	BTO03.17.00	Lateral externa direita/Lateral derecha	710x496x15	01	208894	208894	208894
02	BTO03.18.00	Lateral externa esquerda/Lateral izquierda	710x496x15	01	208895	208895	208895
03	BTO03.01.01	Base inferior/Base inferior	1200x516x15	01	208907	208907	208907
04	BTO03.13.00	Forro/Revés	1190X337x2.5	02	208900	208900	208900
05	BTO03.20.00	Lateral interna/Lado interno	660x496x15	01	208896	208896	208896
06	BTO03.28.00	Ripa balcão frontal/Travesaño	1170x50x15	02	208897	208897	208897
07	BTO03.02.00	Base interna/Base pequena	795x360x15	01	208899	208899	208899
08	BTO03.14.00	Frente gaveta/Frente cajón	370x349x15	02	208986	209123	208975
09	BTO03.15.00	Lateral gaveta/Lateral cajón	350x200x15	02	208901	208901	208901
10	BTO03.29.00	Ripa traseira gaveta/Trasero cajón	306x180x15	01	208903	208903	208903
11	BTO03.34.00	Forro gaveta/Revés cajón	330x355x15	03	208906	208906	208906
12	BTO03.15.01	Lateral gaveta/Lateral cajón	350x100x15	04	208902	208902	208902
13	BTO03.29.01	Ripa traseira gaveta/Trasero cajón	306x80x15	02	208904	208904	208904
14	BTO03.14.01	Frente gaveta/Frente cajón	340x130x15	01	208905	208905	210015
15	BTO03.25.00	Porta balcão/Puerta	702x401x15	02	208985	209119	208974
16	BTO03.28.01	Ripa balcão frontal/Travesaño	1170x50x15	01	208898	208898	208898

Ferragens/Herrajes



 *Usar os parafusos (G) para unir este módulo a outro. Usar los tornillos (G) para unirse este módulo a otro. 

*** Em caso de aquisição do tampo e roda tampo ***

 Este kit de ferragem possui 03 unidades a mais do parafuso (K), 8 (C) e 4 unidades do item (H). 



Medidas em mm

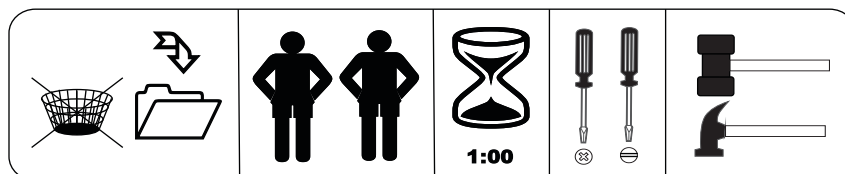

Produto para ser aplicado em caso de riscos na superfície

Pré-Montagem/Preparación Piezas

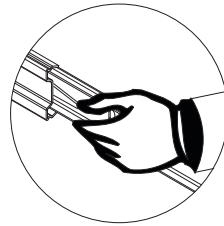
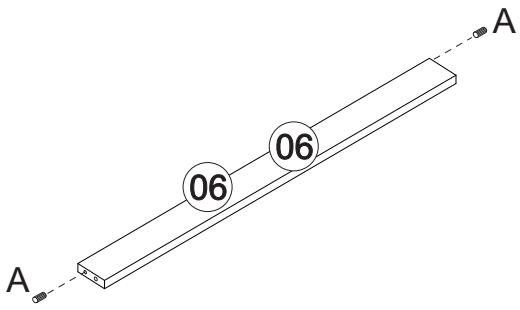

Soltar as partes da correção

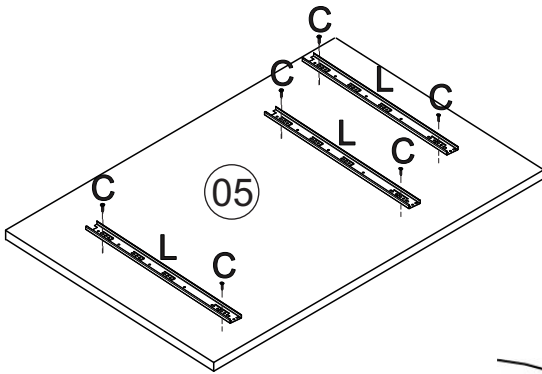
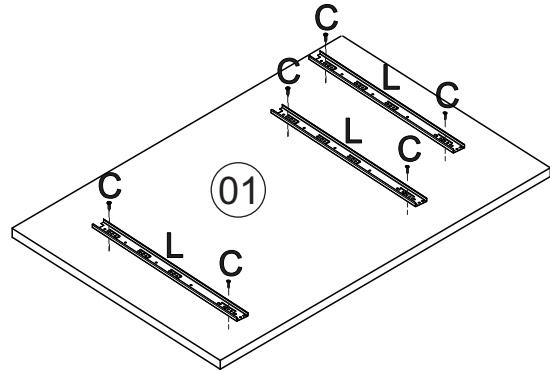
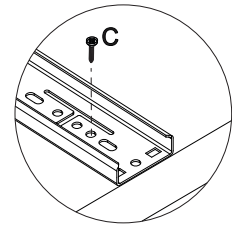

Utilizar cola nas cavilhas.

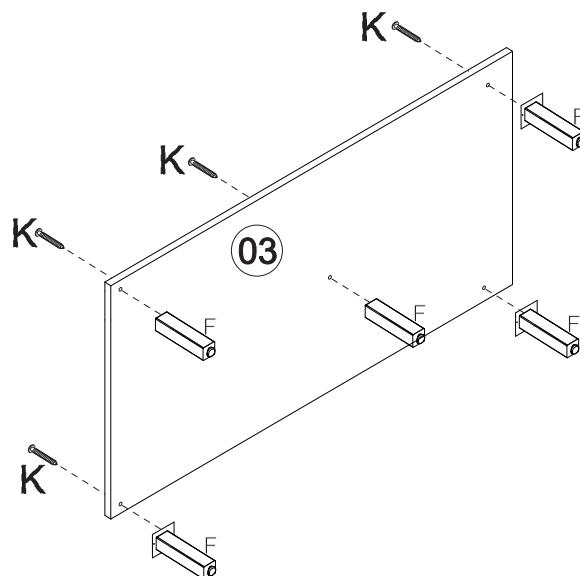
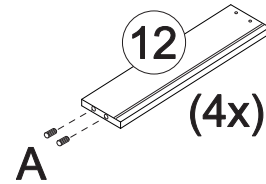
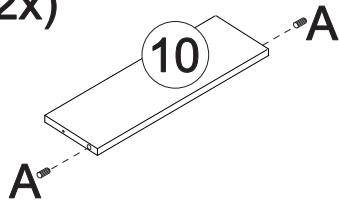
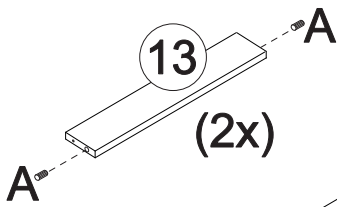
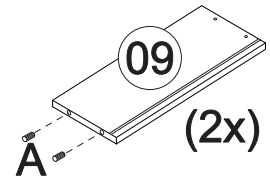

01 Montagem/Montaje

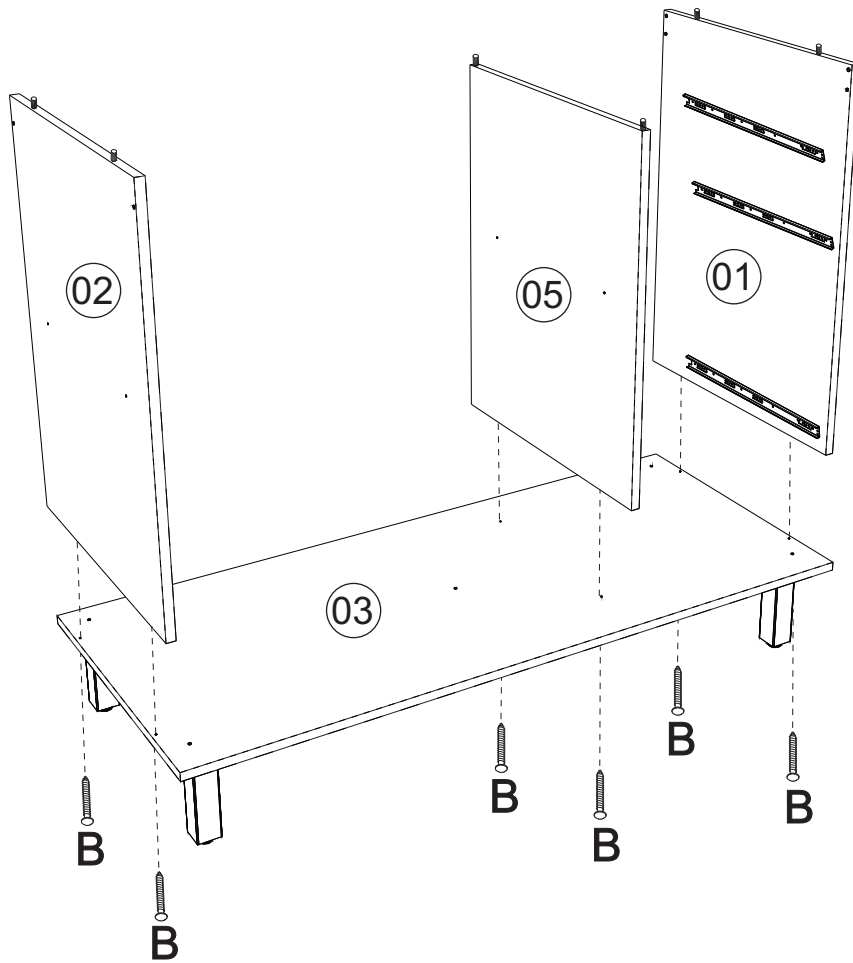

02 Montagem/Montaje

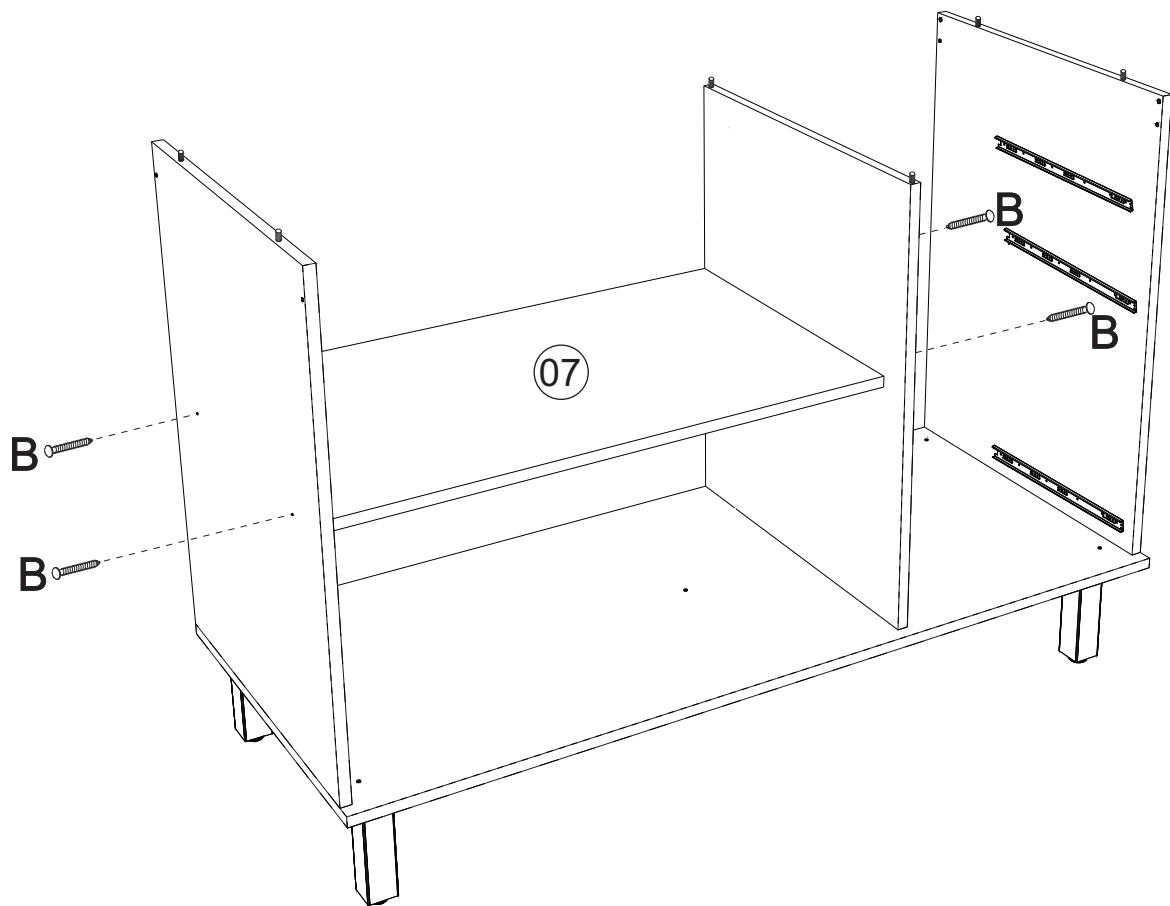

03 Montagem/Montaje

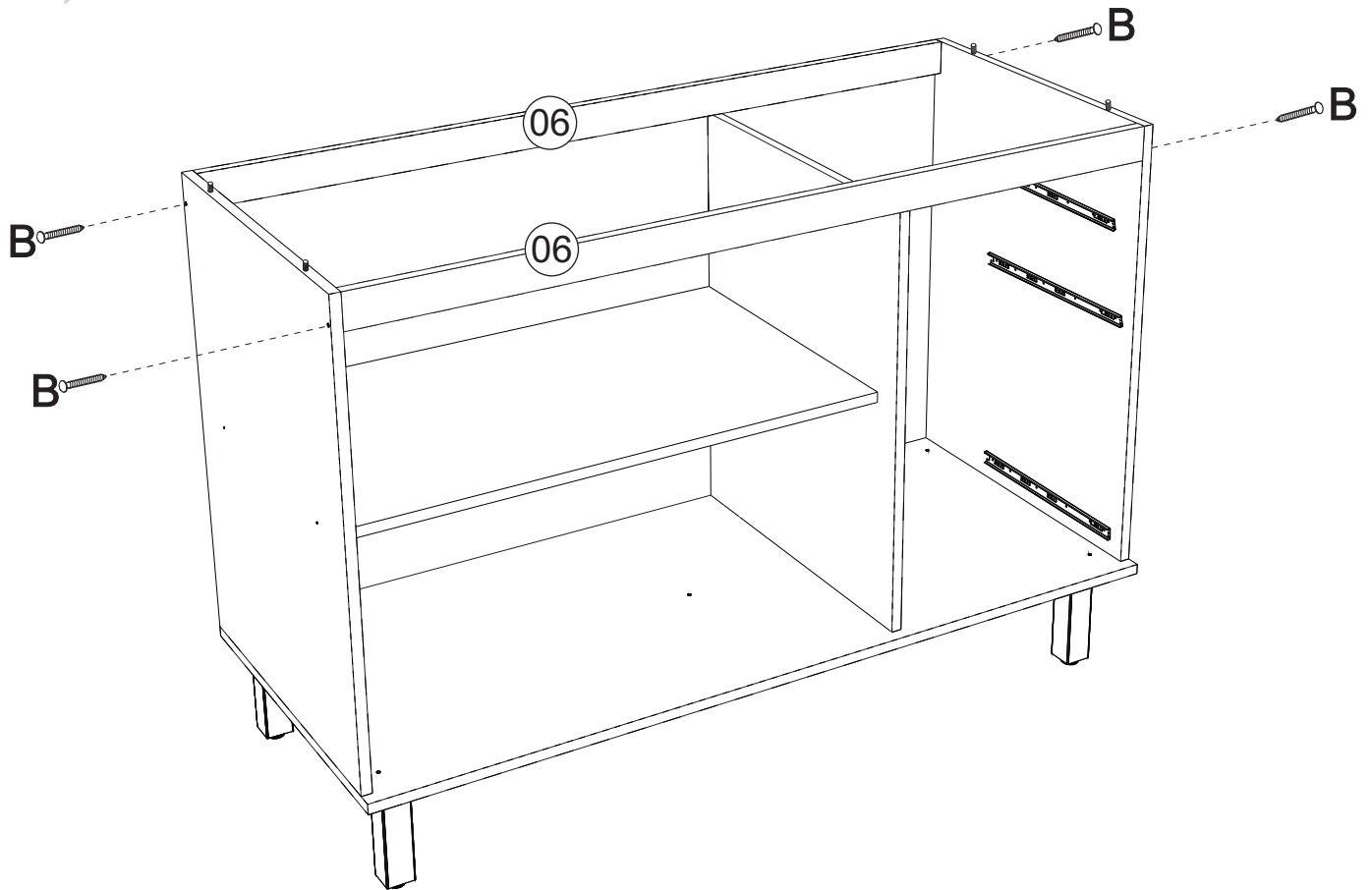

04 Montagem/Montaje

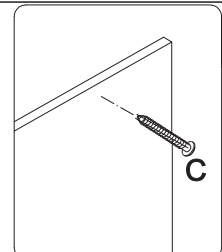
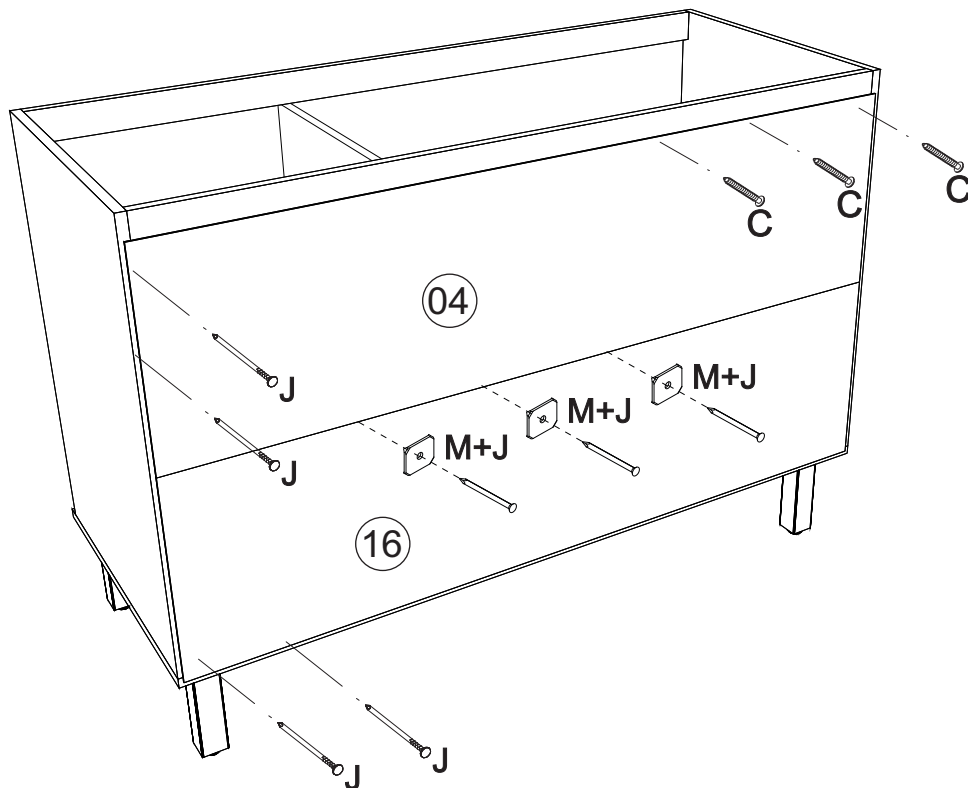

*Colocar um parafuso (C) a cada 100mm

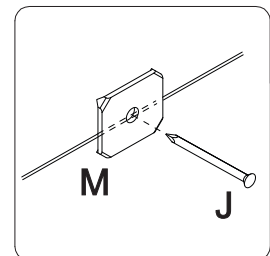

*Colocar o prego (J) e a junção (M) a cada 100mm

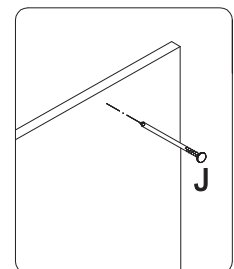

*Colocar um prego (J) a cada 100mm

05 Montagem/Montaje

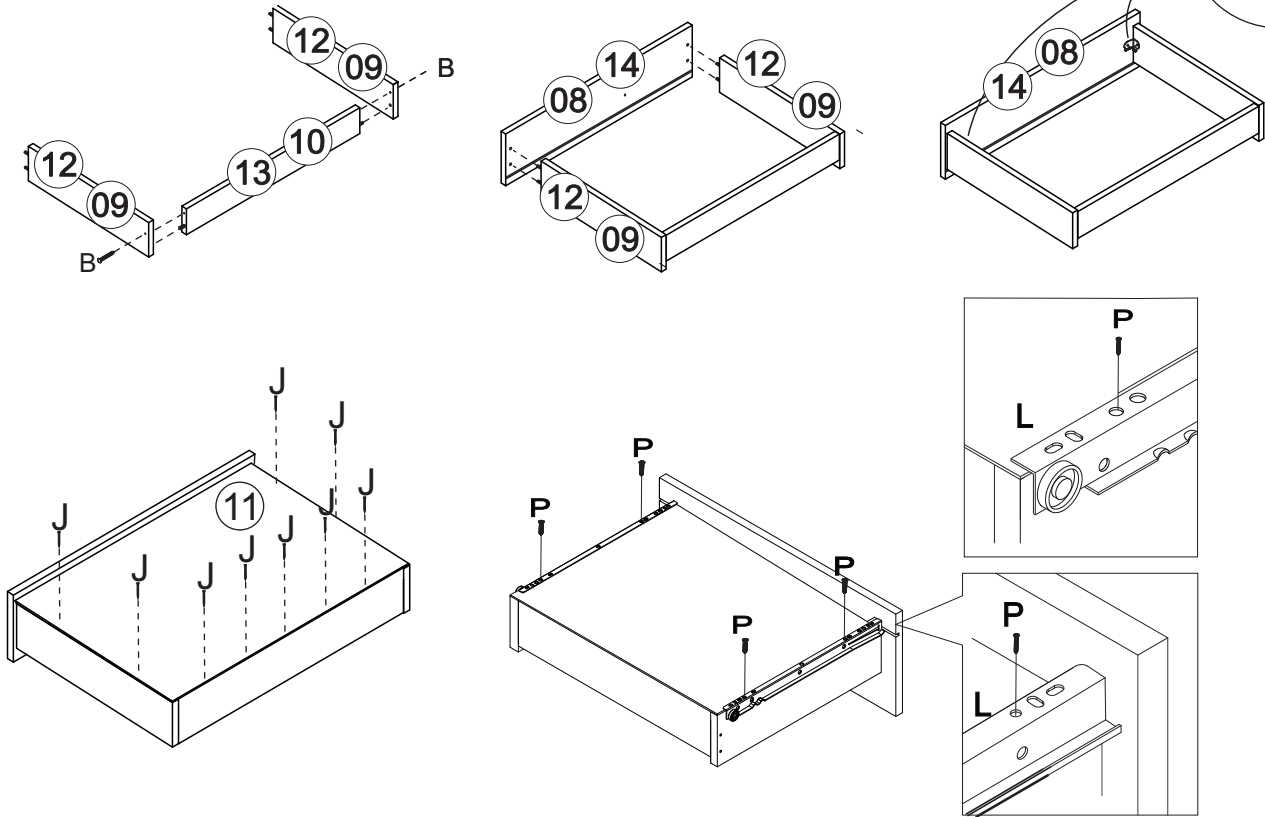
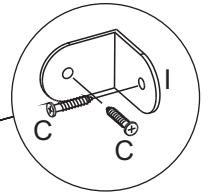

06 Montagem/Montaje

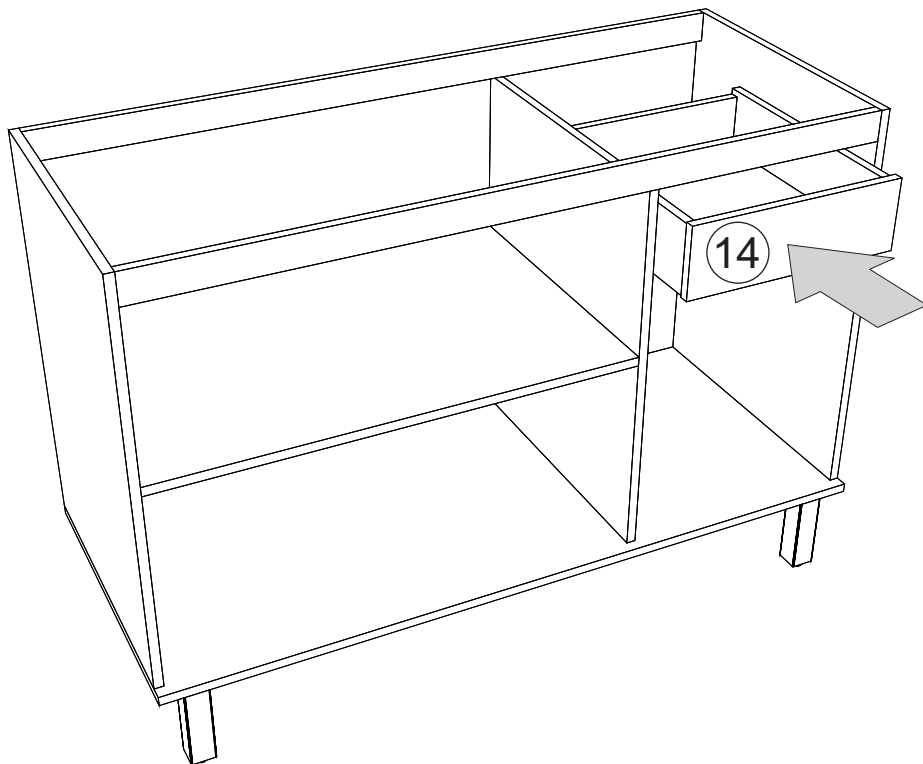

07 → Montagem/Montaje

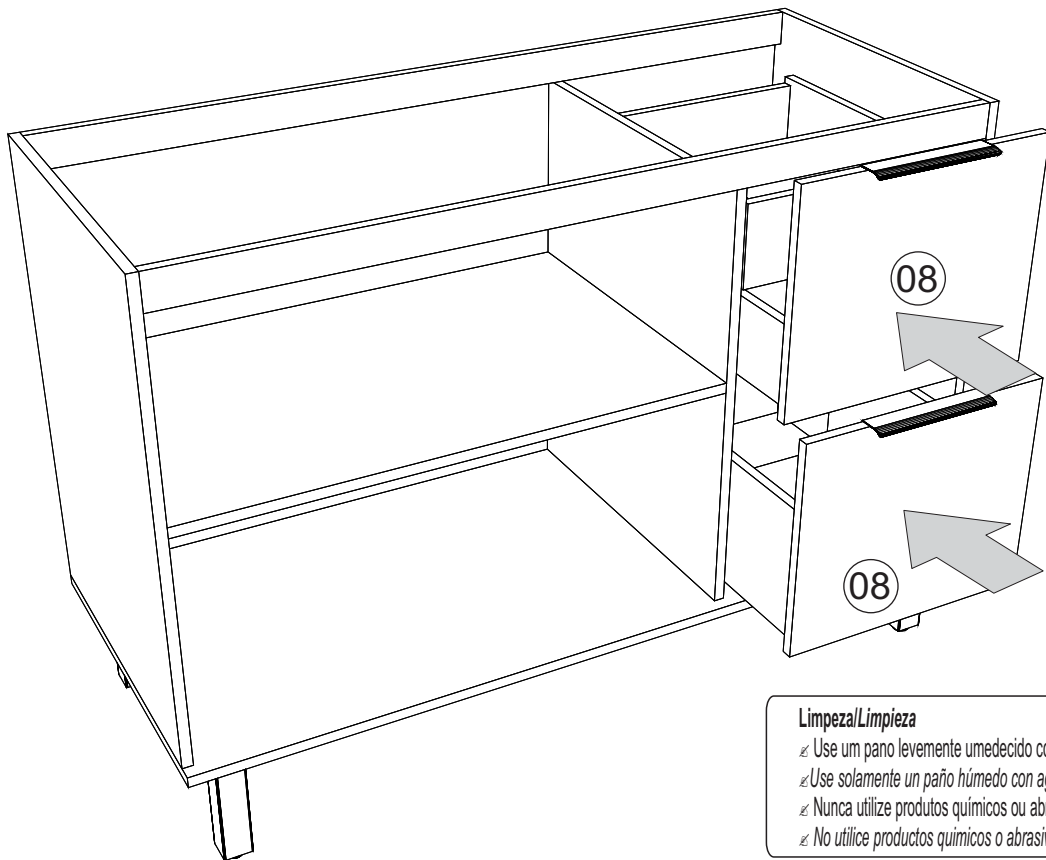

08 → Montagem/Montaje

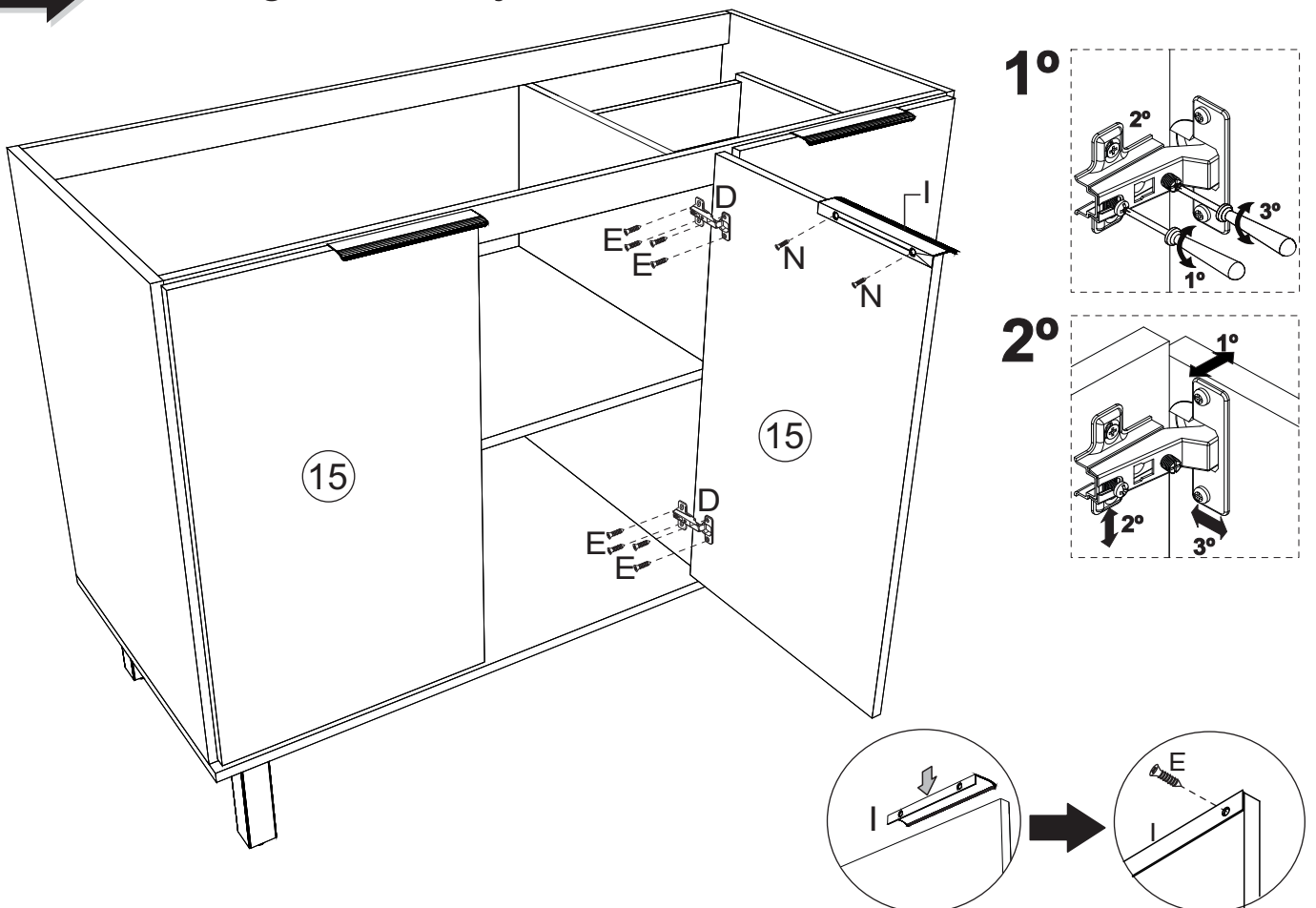

mx

mxmóveis

Rodovia SC-492 - Km 10 - B. Industrial
89905-000 - Bandeirante - SC

Fone: (49) 3622-4549

e-mail: mxmoveis@mxmoveis.com.br

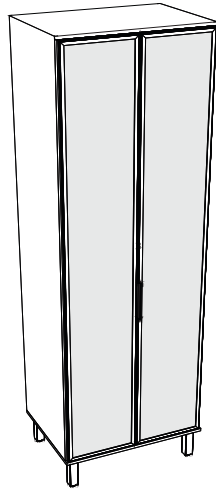

Ref. PTO02

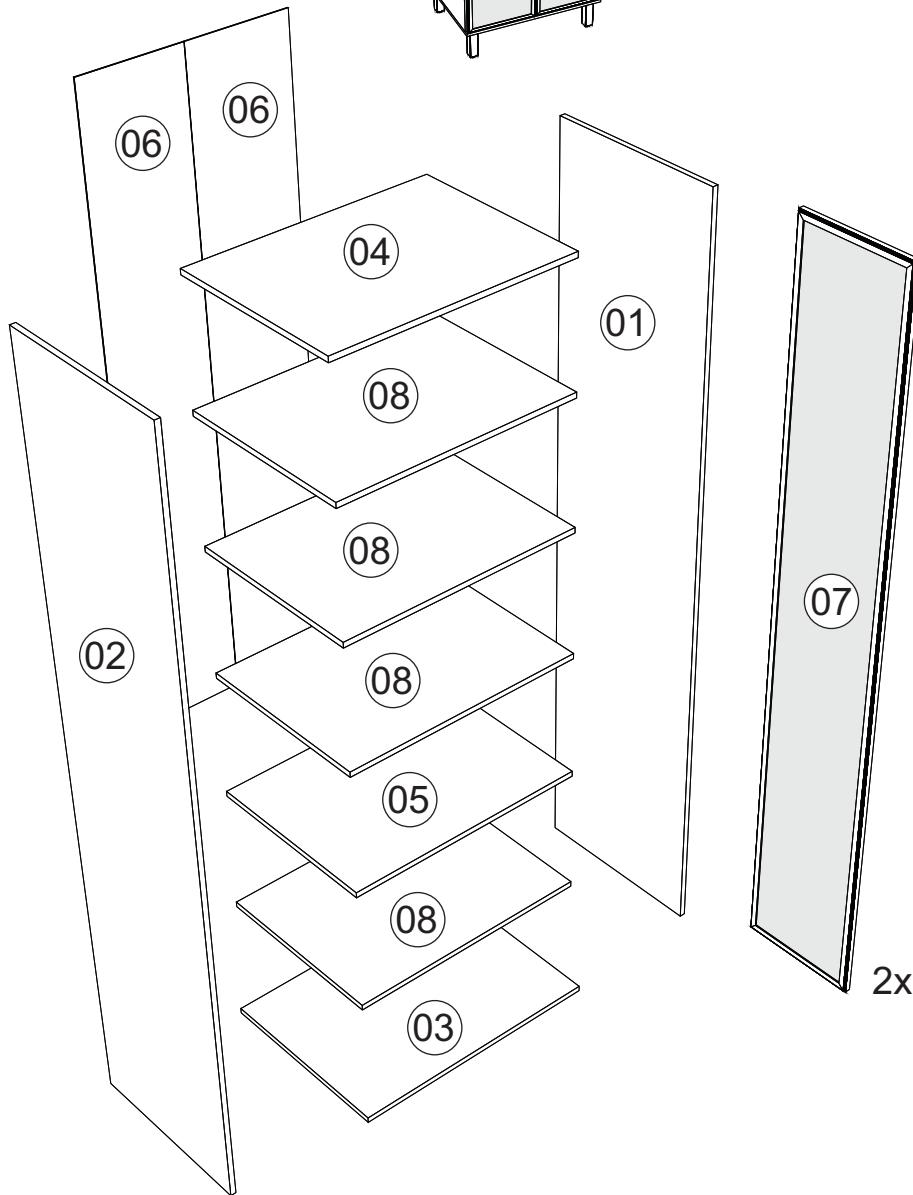

Cristaleira 700
Cozinha/Cocina
TOSCANA

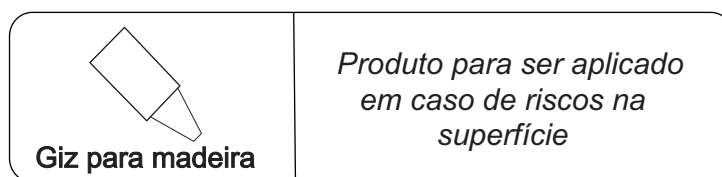
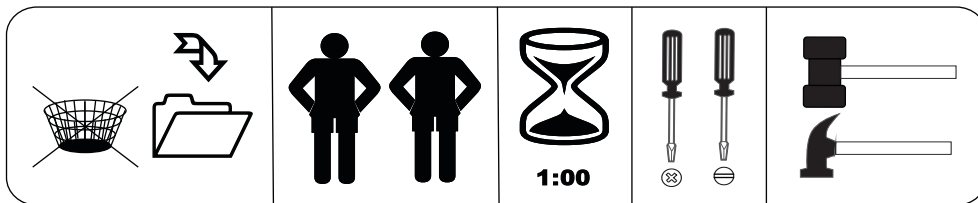
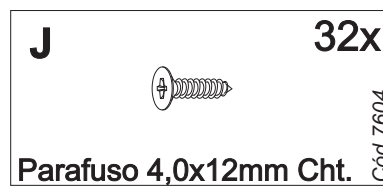
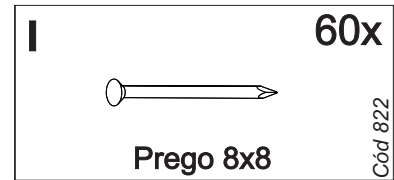
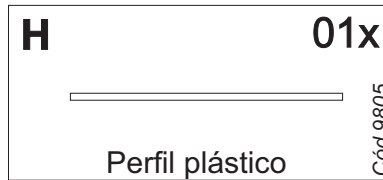
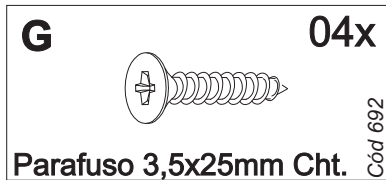
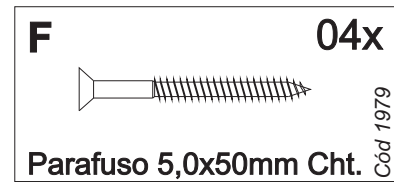
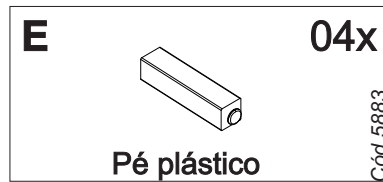
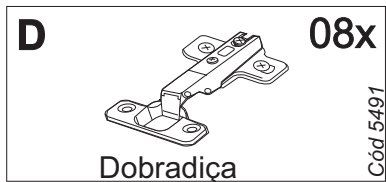
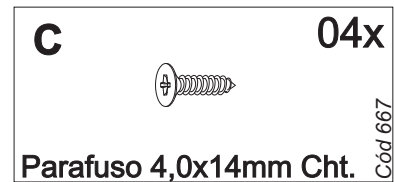
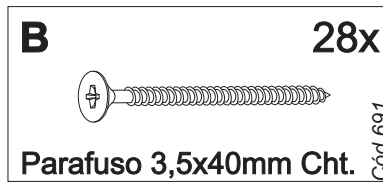
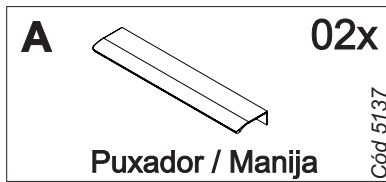

Nº	CÓDIGO ASSISTÊNCIA	NOME DA PEÇA/DESCRIPCIÓN PIEZAS	MEDIDAS (mm)	QTD.	CÓDIGO DAS PEÇAS/ CODIGO PIEZAS
					FREIJO/FREIJO
01	PTO02.17.00	Lateral externa direita/Lateral derecha	2100x496x15	01	209253
02	PTO02.18.00	Lateral externa esquerda/Lateral izquierda	2100x496x15	01	209255
03	PTO02.01.01	Base inferior/Base inferior	700x516x15	01	209260
04	PTO02.05.01	Base superior/Base superior	700x516x15	01	209259
05	PTO02.02.00	Base Interna/Base pequena	670x496x15	01	209256
06	PTO02.13.00	Forro/Revés	2116x345x2.5	02	209258
07	5269	Porta/Puerta	2089x339x20	02	
08	PTO02.02.01	Base Interna/Base pequena	670x450x15	04	209257

Ferragens/Herrajes



 *Usar os parafusos (G) para unir este módulo a outro.  Usar los tornillos (G) para unirse este módulo a otro.

Pré-Montagem/Preparación Piezas

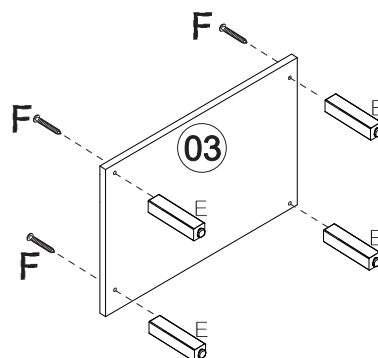

01

Montagem/Montaje

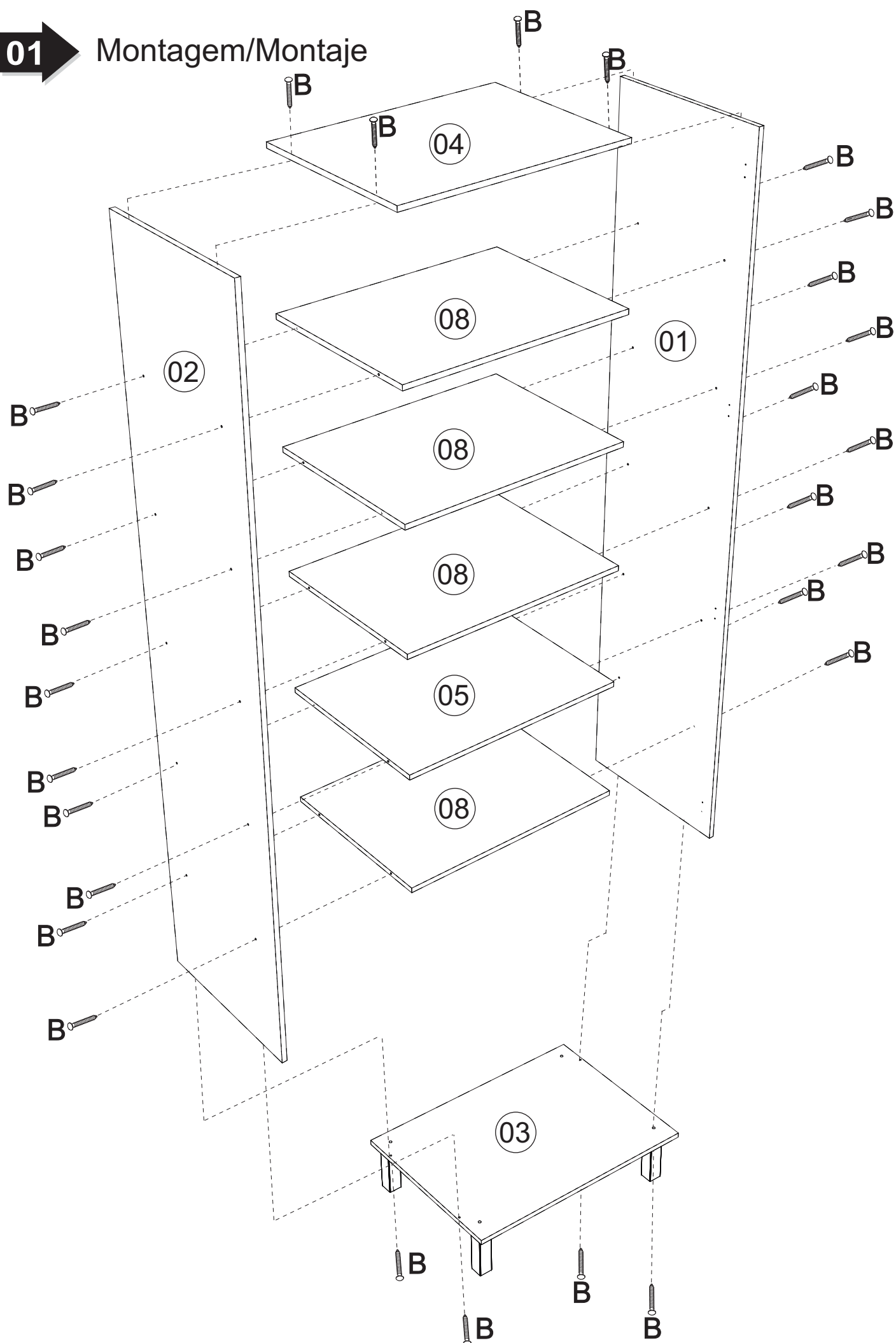

02 Montagem/Montaje

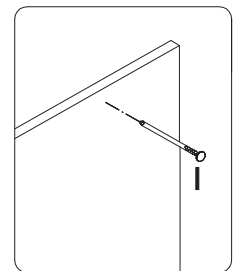
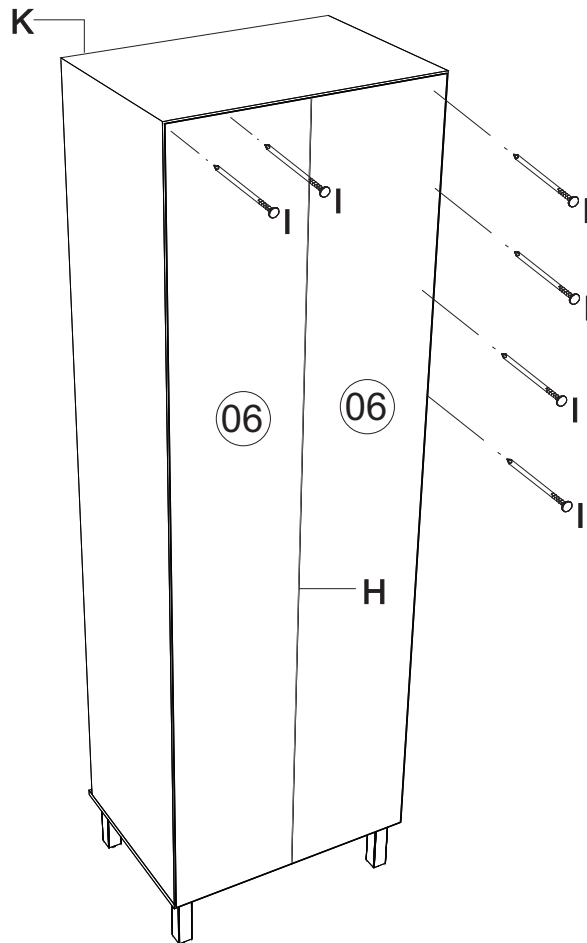

*Colocar um prego (I) a cada 100mm

03 Montagem/Montaje

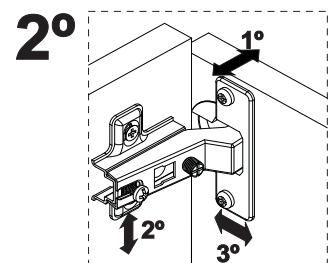
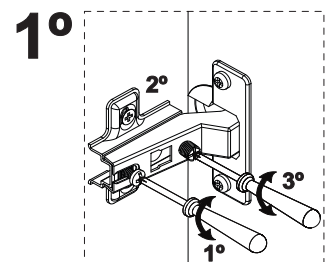
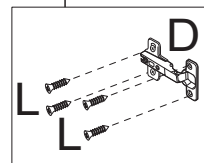
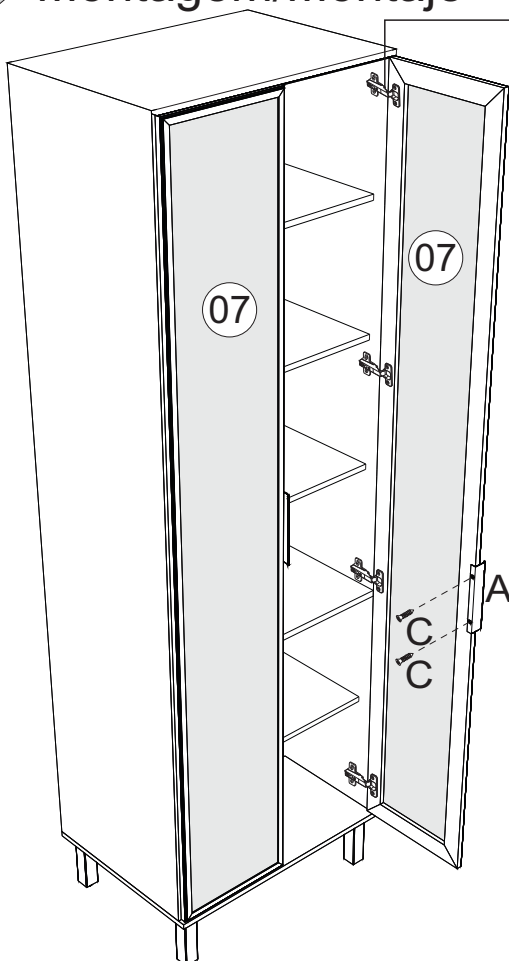

Limpeza/Limpieza

- ✗ Use um pano levemente umedecido com água, seguido de pano seco.
- ✗ Use solamente un paño húmedo con agua y después un paño seco.
- ✗ Nunca utilize produtos químicos ou abrasivos.
- ✗ No utilice productos químicos o abrasivos.

mx

mxmóveis

Rodovia SC-492 - Km 10 - B. Industrial
89905-000 - Bandeirante - SC

Fone: (49) 3622-4549

e-mail: mxmoveis@mxmoveis.com.br

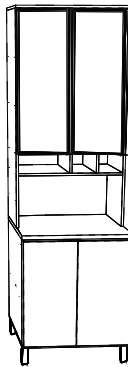

Ref. PTO01

Paneleiro
Cozinha/Cocina
TOSCANA

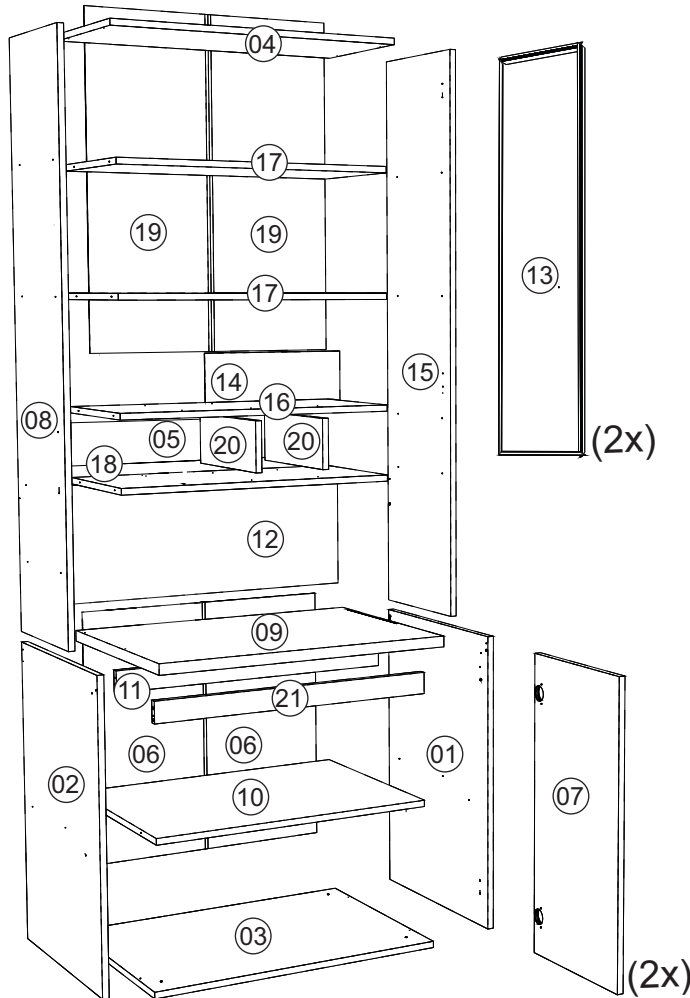

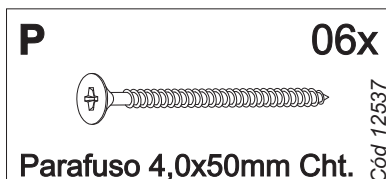
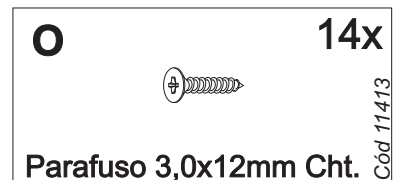
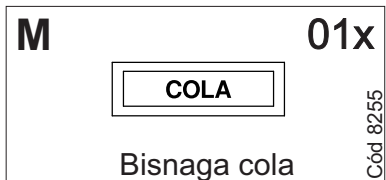
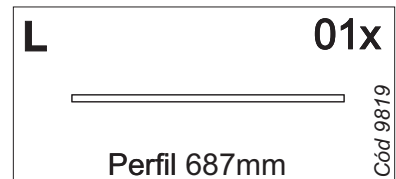
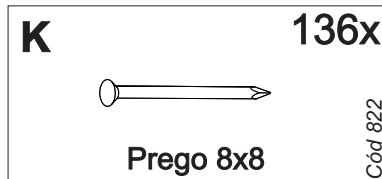
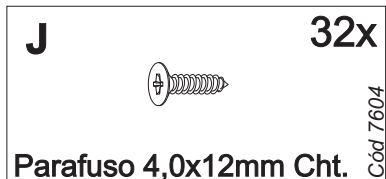
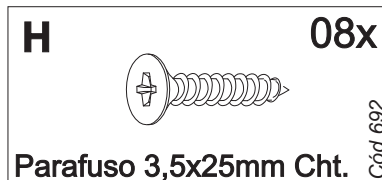
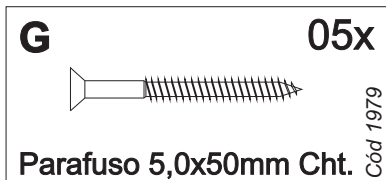
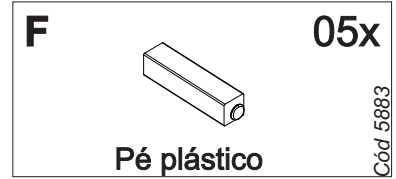
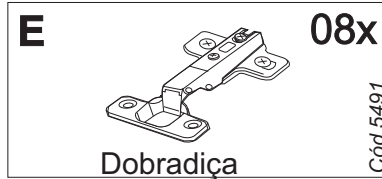
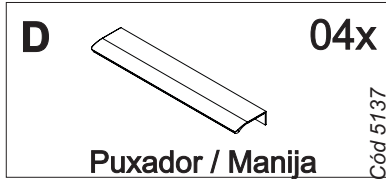
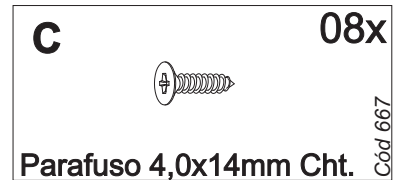
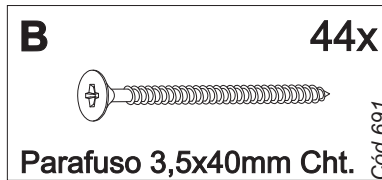

Nº	CÓDIGO ASSISTÊNCIA	NOME DA PEÇA/DESCRIPCIÓN PIEZAS	MEDIDAS (mm)	QTD.	CÓDIGO DAS PEÇAS/ CÓDIGO PIEZAS		
					FREIJÓ/FREIJO	FREIJÓ/NERO	FREIJÓ/JADE
01	PTO01.17.00	Lateral externa direita/Lateral derecha	710x496x15	01	209162	209162	209162
02	PTO01.18.00	Lateral externa esquerda/Lateral izquierda	710x496x15	01	209163	209163	209163
03	PTO01.01.00	Base inferior/Base inferior	700x516x15	01	209161	209161	209161
04	PTO01.05.00	Base superior/Base superior	700x290x15	01	209175	209175	209175
05	PTO01.40.00	Painel	690x135x6	01	209171	209171	209171
06	PTO01.13.00	Forro/Revés	687x342x2.5	02	209167	209167	209167
07	PTO01.25.00	Porta/Puerta	702x339x15	02	209154	209250	209246
08	PTO01.18.01	Lateral externa esquerda/Lateral izquierda	1365x270x15	01	209170	209170	209170
09	PTO01.33.00	Tampo	700x516x22	01	209168	209168	209168
10	PTO01.02.02	Base interna	670x496x15	01	210471	210471	210471
11	PTO01.28.01	Ripa sustentação	670x50x15	01	209166	209166	209166
12	PTO01.13.03	Forro/Revés	690x360x2.5	01	209178	209178	209178
13	5269	Porta/Puerta	2089x339x20	02			
14	PTO01.13.01	Forro/Revés	684x164x2.5	01	209176	209176	209176
15	PTO01.17.01	Lateral externa direita/Lateral direita	1365x270x15	01	209169	209169	209169
16	PTO01.02.00	Base interna	670x270x15	01	209173	209173	209173
17	PTO01.02.01	Base interna	670x270x15	02	209174	209174	209174
18	PTO01.02.04	Base Interna	670x270x15	01	209179	209179	209179
19	PTO01.13.02	Forro/Revés	889x342x2.5	02	209177	209177	209177
20	PTO01.19.00	Lateral interna menor	270x120x15	02	209172	209172	209172
21	PTO01.28.00	Ripa sustentação	670x50x15	01	209165	209165	209165

Ferragens/Herrajes



Medidas em mm

 *Usar os parafusos (G) para unir este módulo a outro. Usar los tornillos (G) para unirse este módulo a otro. 

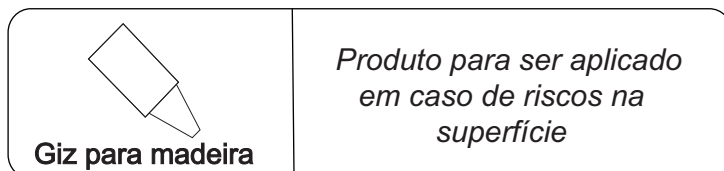
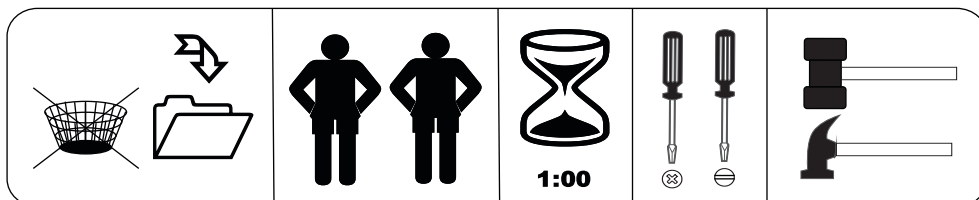

Pré-Montagem/Preparación Piezas



Utilizar
cola nas
cavilhas.

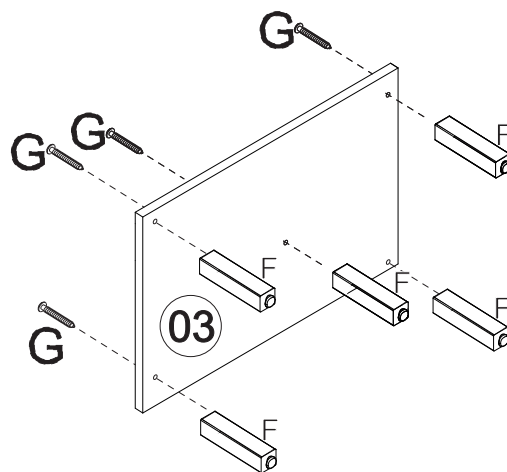
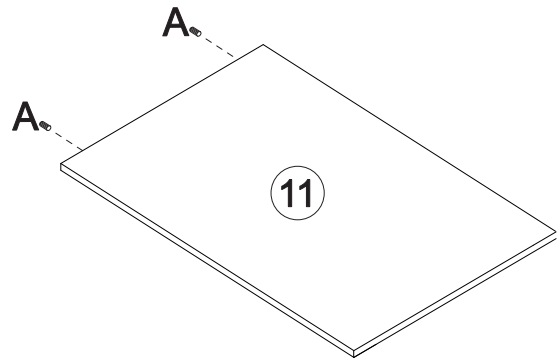
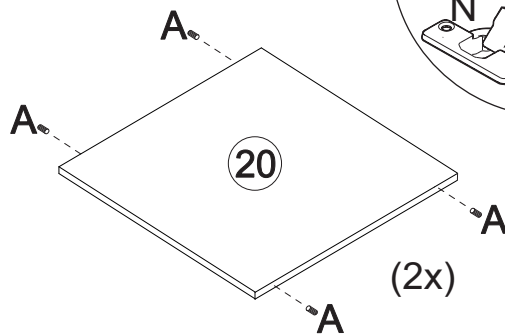
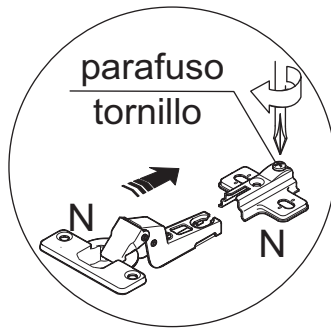
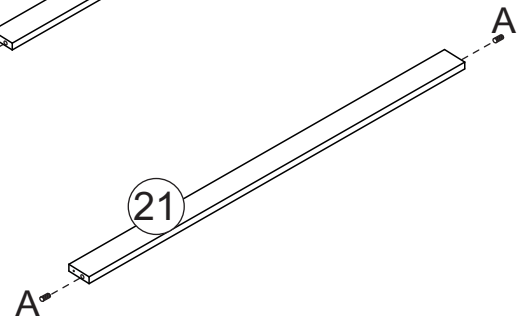
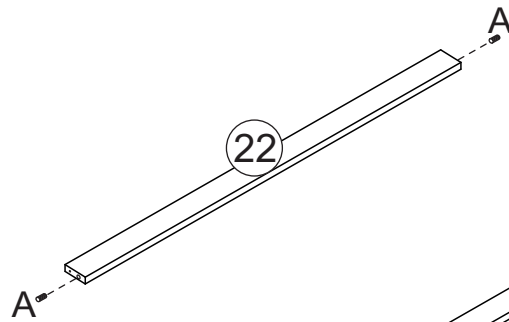
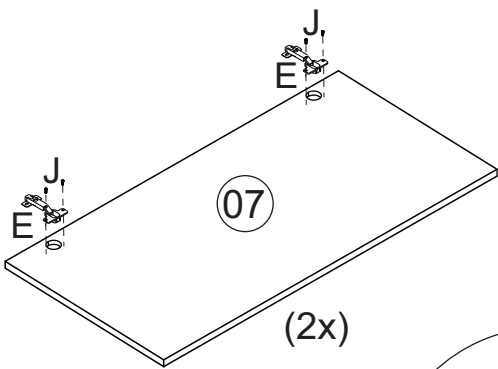
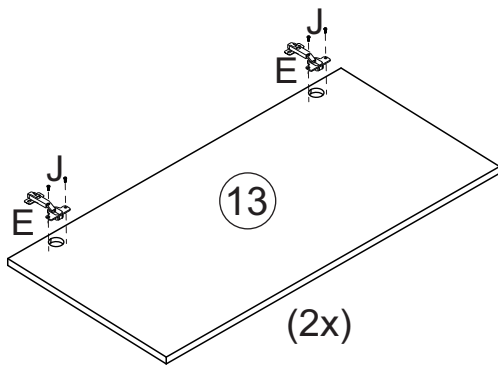

01 Montagem/Montaje

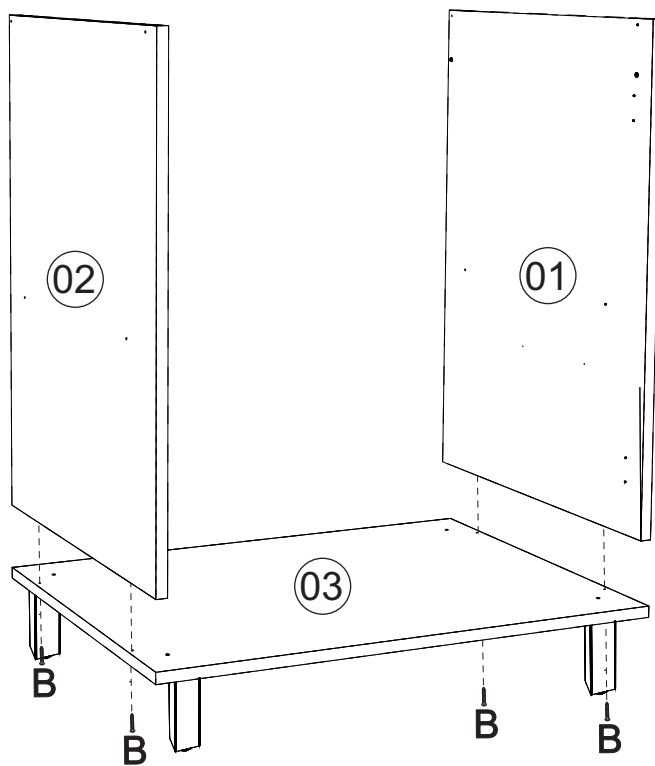

02 Montagem/Montaje

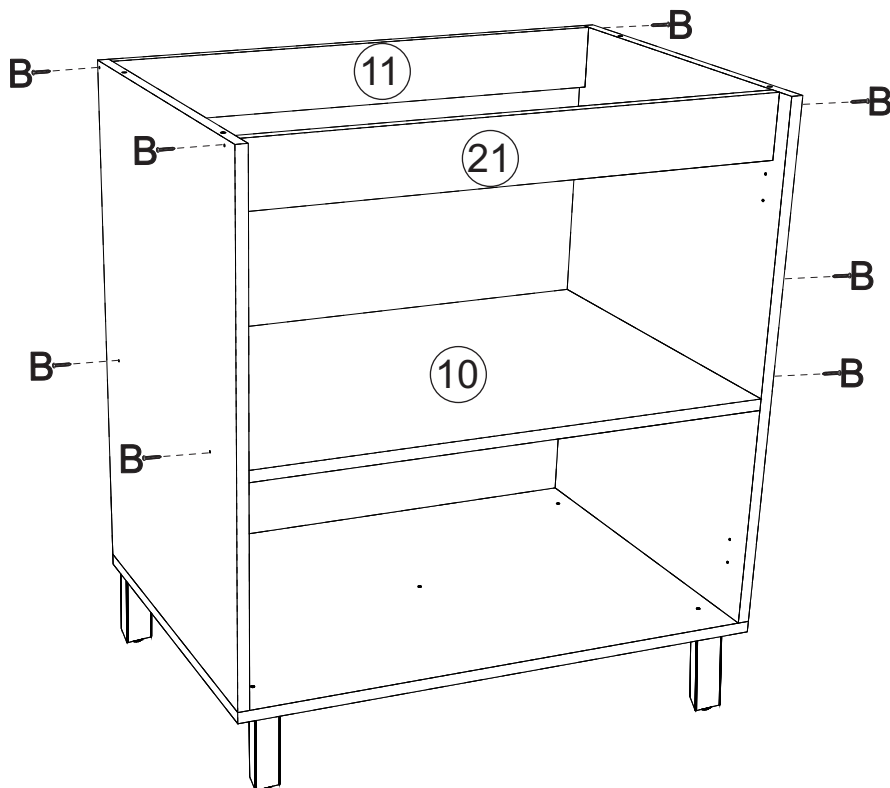

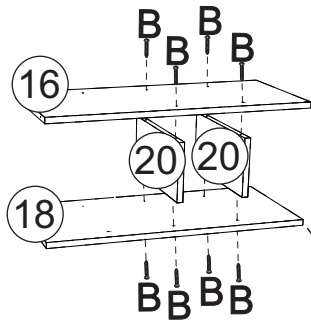
03**Montagem/Montaje**

Tomada USB deve ser encaixada no painel

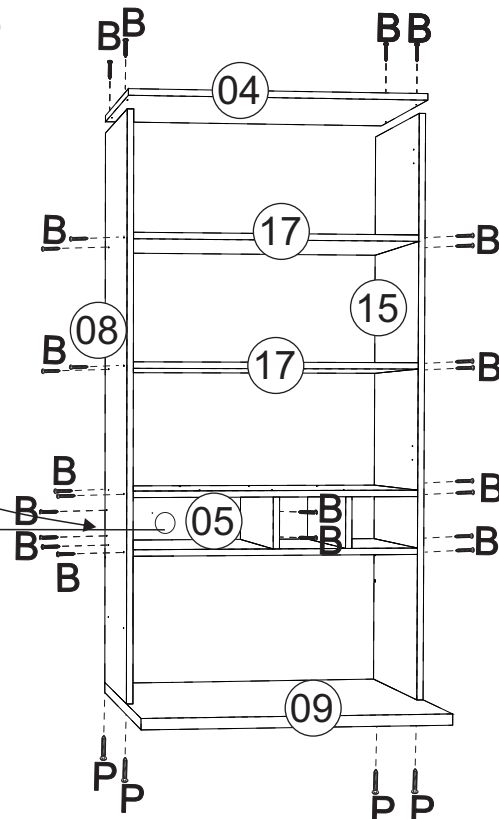

Obs: São utilizados 4 parafusos 4,0x50 para melhor fixação do paneleiro

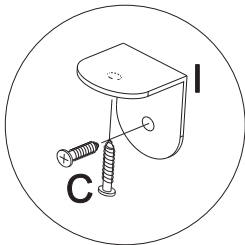
04**Montagem/Montaje**

Obs: são utilizados 4 cantoneira para fixação do tampo.

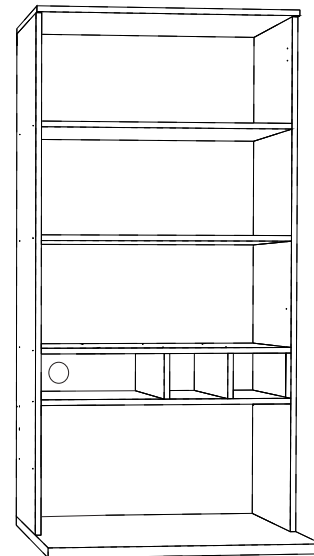
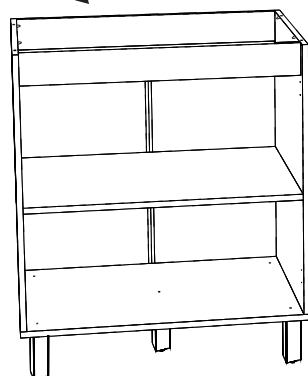

05 Montagem/Montaje

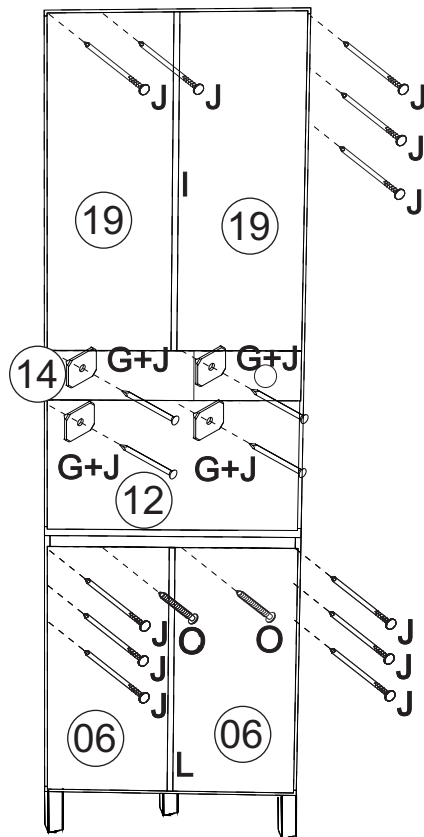

06 Montagem/Montaje

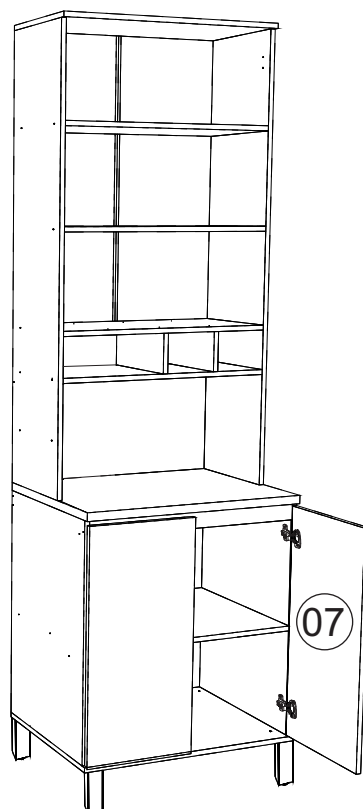

07

Montagem/Montaje

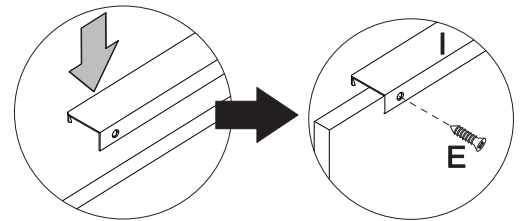
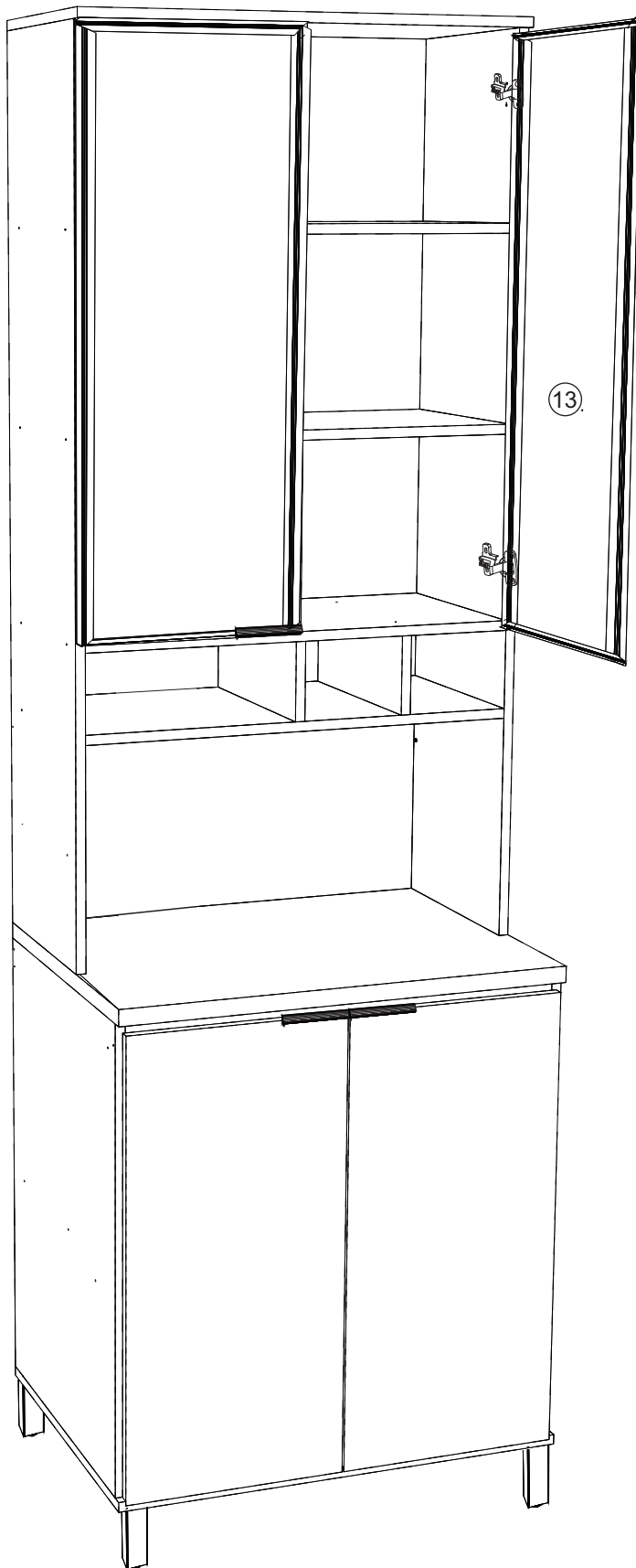

Limpeza/Limpieza

- ✍ Use um pano levemente umedecido com água, seguido de pano seco.
- ✍ *Use solamente un paño húmedo con agua y después un paño seco.*
- ✍ Nunca utilize produtos químicos ou abrasivos.
- ✍ *No utilice productos quimicos o abrasivos.*



Rodovia SC-492 - Km 10 - B. Industrial
89905-000 - Bandeirante - SC
Fone: (49) 3622-4549
e-mail: mxmoveis@mxmoveis.com.br

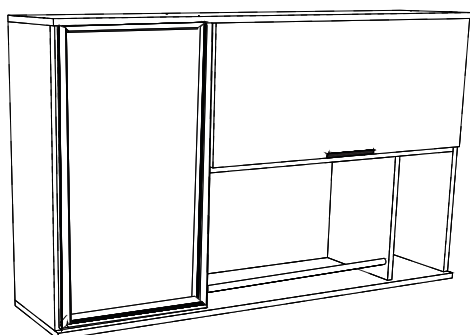

Ref. ATO05

Aéreo 1200
Armario 1200

Cozinha/Cocina
TOSCANA

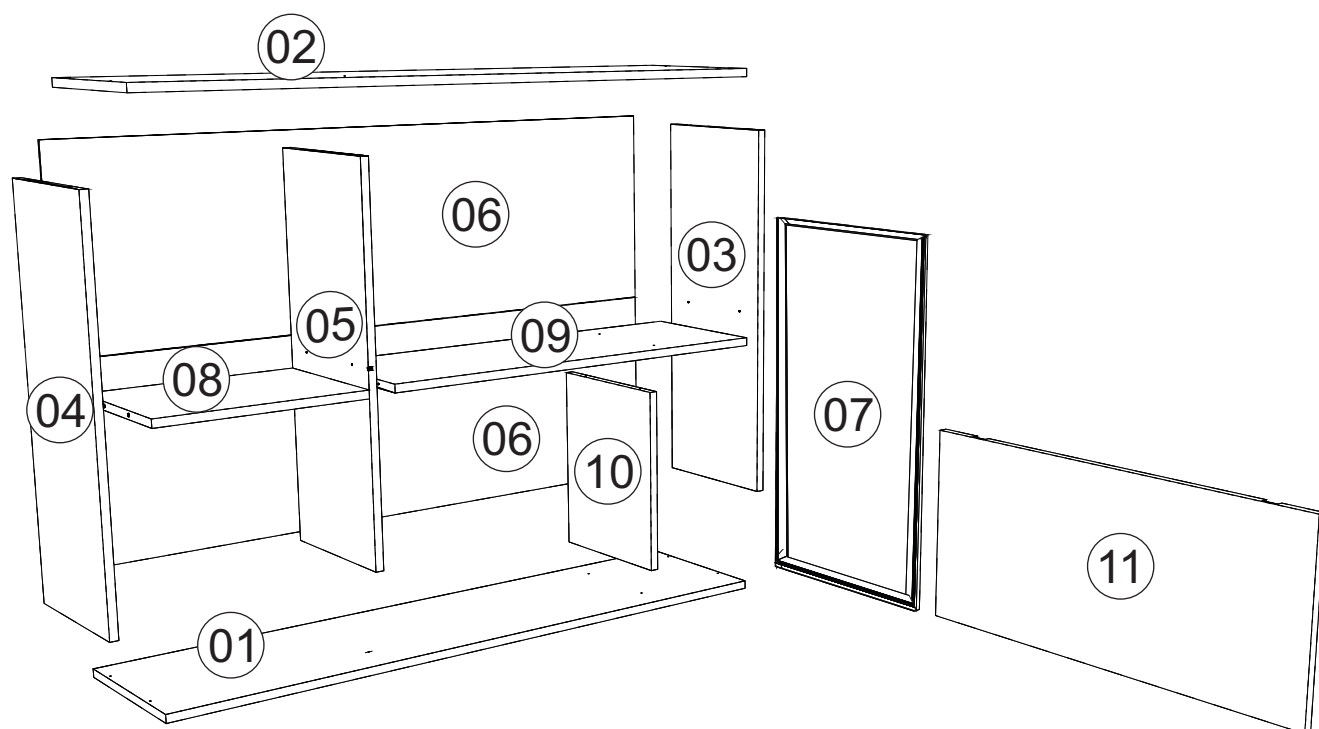

Nº	Código	NOME DA PEÇA/DESCRIPCIÓN PIEZAS	MEDIDAS (mm)	QTD.	CÓDIGO DAS PEÇAS/ CÓDIGO PIEZAS
					FREIJÓ/FREIJÓ
01	ATO05.01.00	Base inferior/Base inferior	1200x290x15	01	208611
02	ATO05.05.00	Base superior/Base superior	1200x290x15	01	208612
03	ATO05.17.01	Lateral externa direita/Lateral derecha	710x270x15	01	209975
04	ATO05.18.01	Lateral externa esquerda/Lateral izquierda	710x270x15	01	209976
05	ATO05.19.02	Lateral interna/Divisoria	710x270x15	01	209977
06	ATO05.13.01	Forro/Revés	1190x361x2,5	02	209980
07	5266	Porta vidro/Puerta	702x389x20	01	
08	ATO05.02.01	Base interna/Base pequena	382x270x15	01	208617
09	ATO05.02.00	Base interna/Base pequena	773x270x15	01	208614
10	ATO05.19.03	Lateral interna inf. /Divisoria	347x267x15	01	209978
11	ATO05.25.01	Porta/Puerta	788x352x15	01	209979

Ferragens/Herrajes

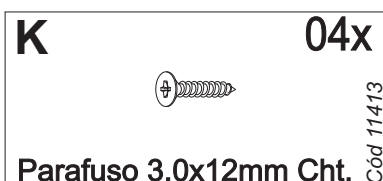
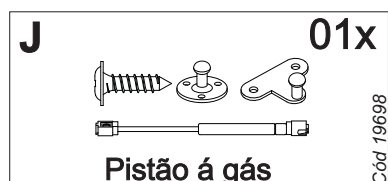
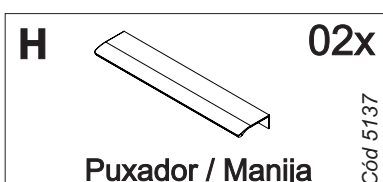
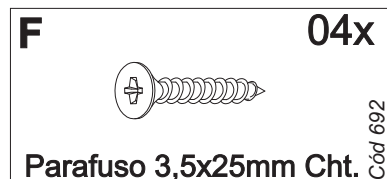
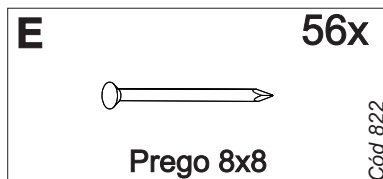
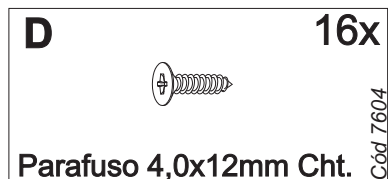
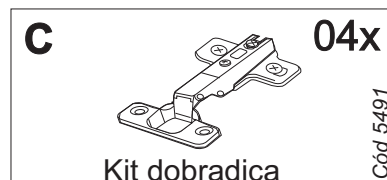
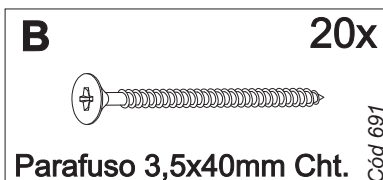

*Usar os parafusos (F) para unir este módulo a outro.
Usar los tornillos (F) para unirse este módulo a otro.



Medidas em mm

Pré-Montagem/Preparación Piezas

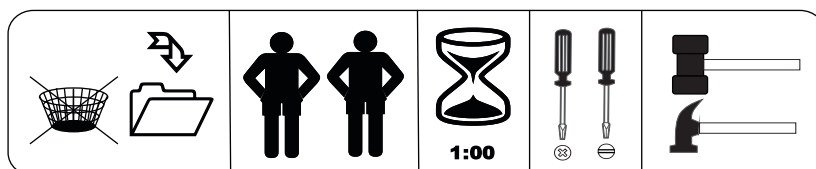
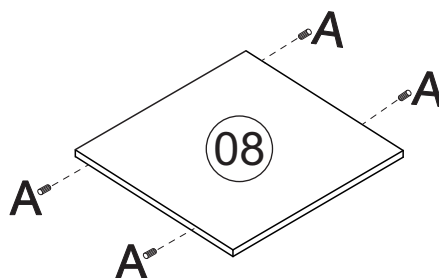

Produto para ser aplicado
em caso de riscos na
superfície

01 → Montagem/Montaje

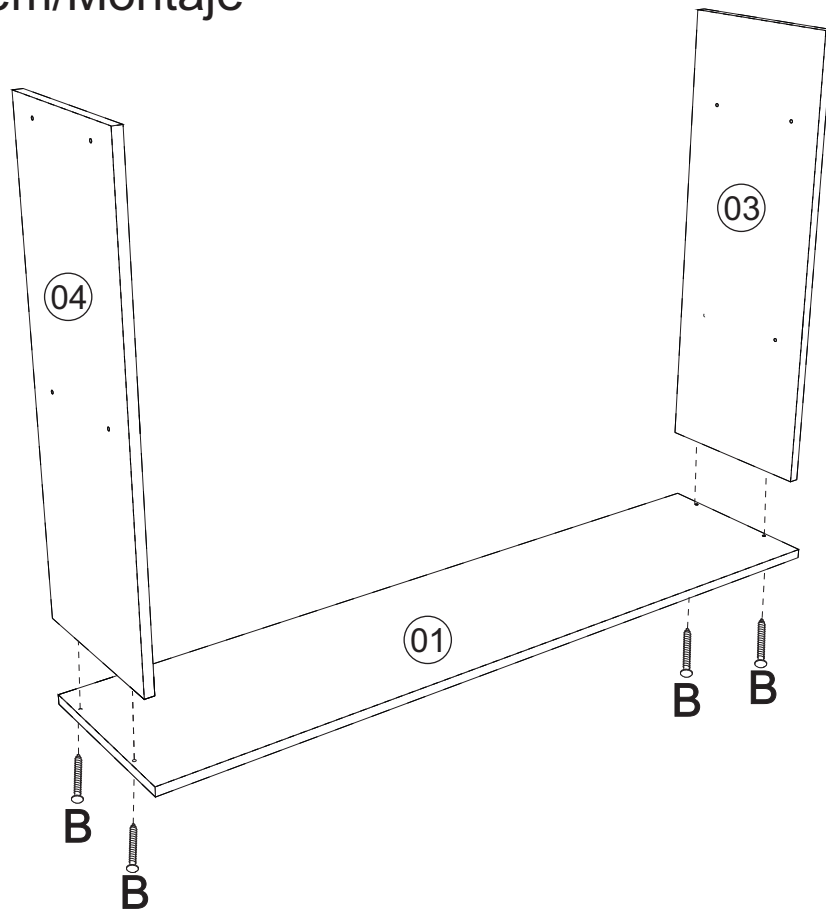

02 → Montagem/Montaje

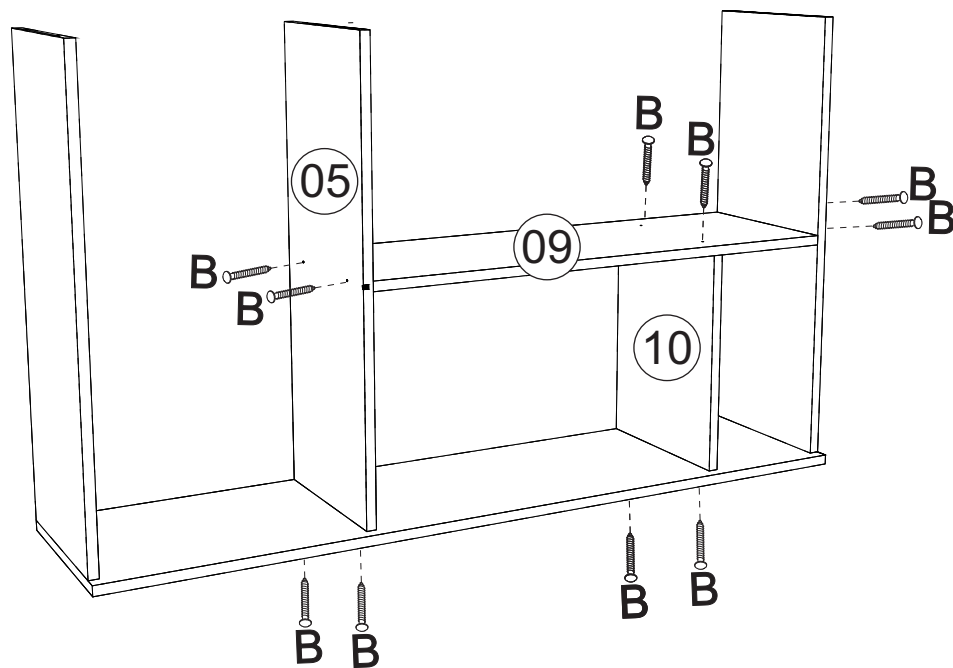

03 Montagem/Montaje

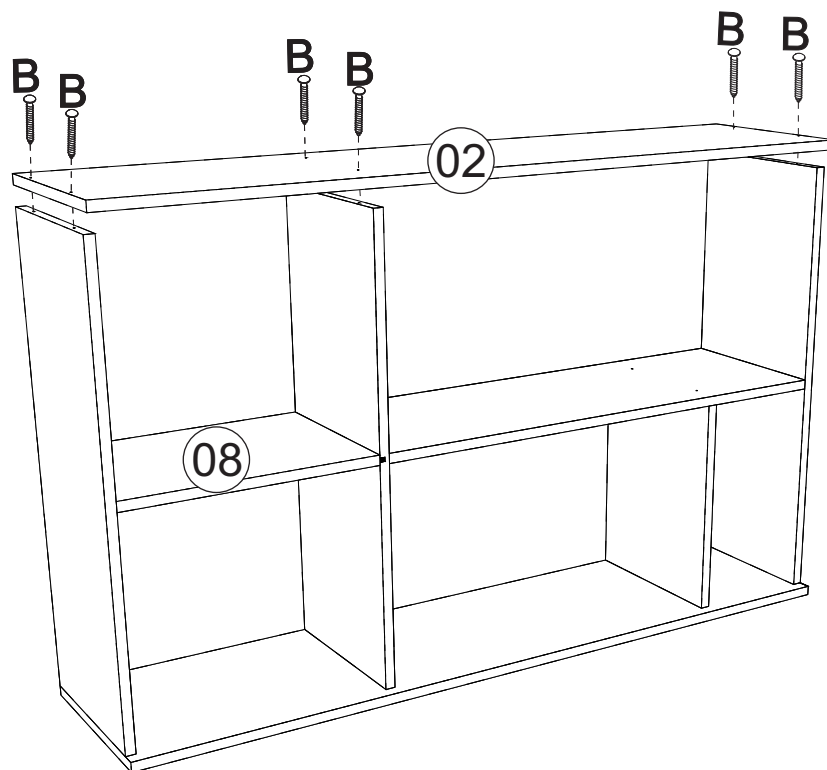

04 Montagem/Montaje

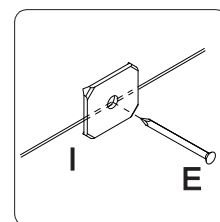
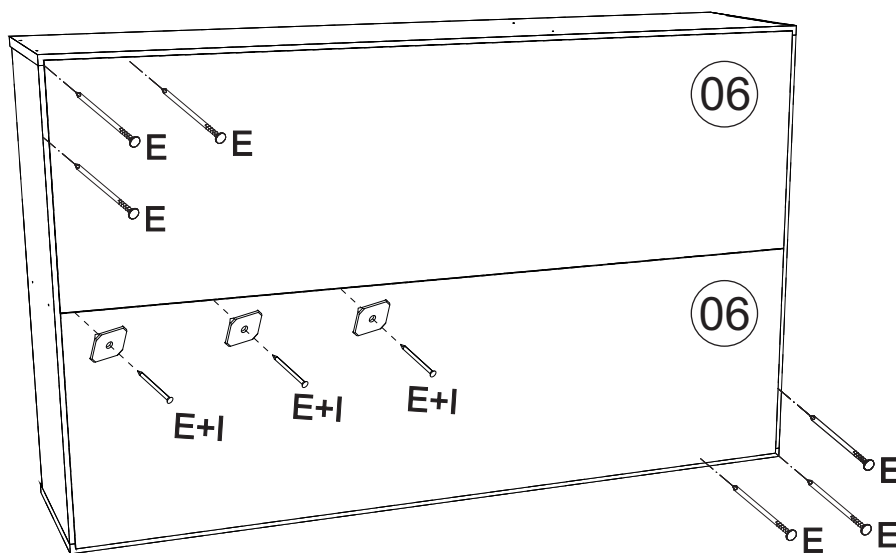

*Colocar o prego (E) e a junção (I) a cada 100mm

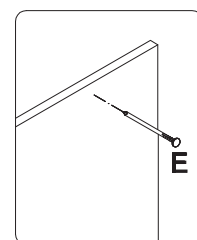

*Colocar um prego (E) a cada 100mm

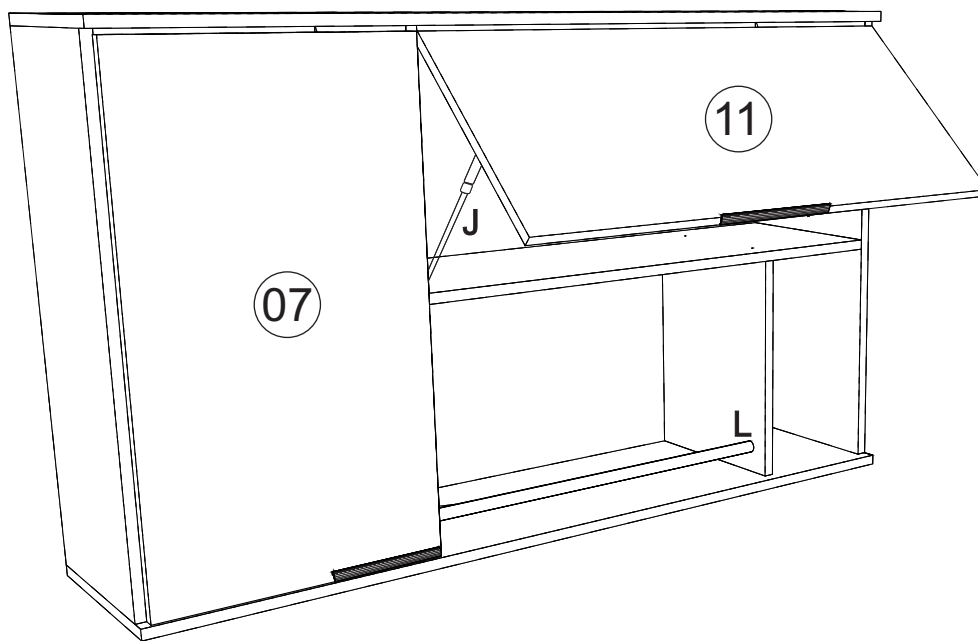
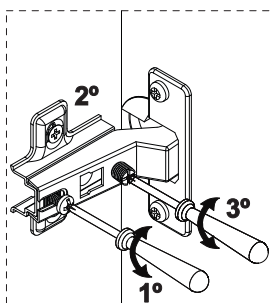
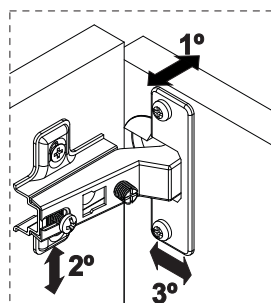
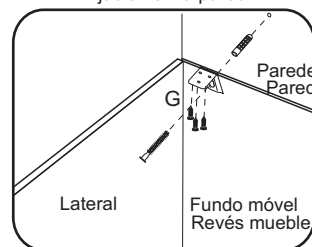
06**Montagem/Montaje****1°****2°**Fixação na parede
Fijación en la pared

*Fixar a cantoneira na parte interna do móvel.
Fijar la pieza «G» en el interior del mueble.

Limpeza/Limpieza

- ✍ Use um pano levemente umedecido com água, seguido de pano seco.
- ✍ *Use solamente un paño húmedo con agua y después un paño seco.*
- ✍ Nunca utilize produtos químicos ou abrasivos.
- ✍ *No utilice productos quimicos o abrasivos.*