

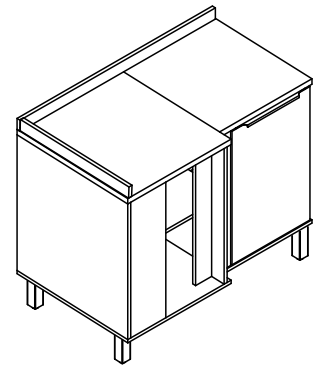

Rodovia SC-492 - Km 10 - B. Industrial
89905-000 - Bandeirante - SC
Fone: (49) 3622-4549
e-mail: mxmoveis@mxmoveis.com.br

Ref. BTO04

Balcão Canto
Balcón Esquinero
Cozinha/Cocina
TOSCANA

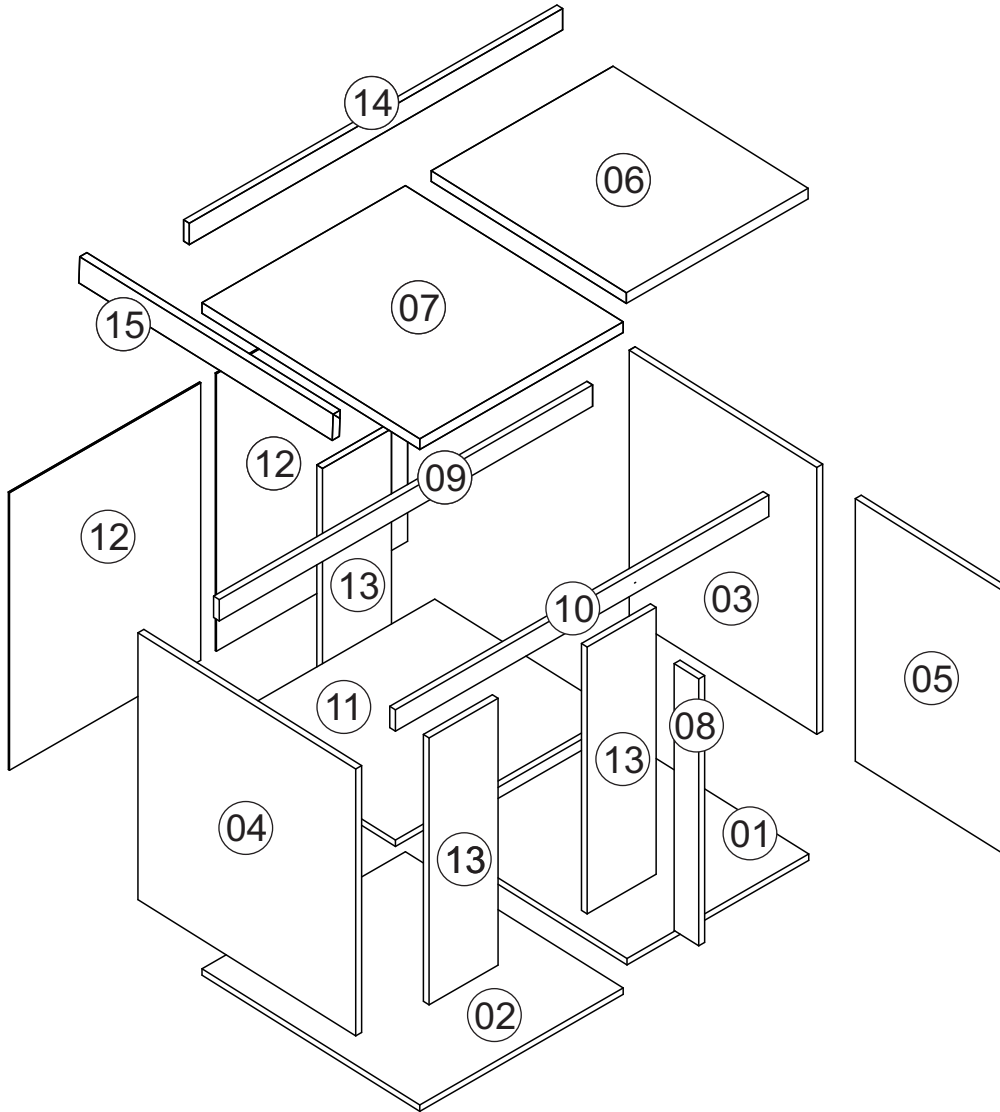

Direito/Derecho

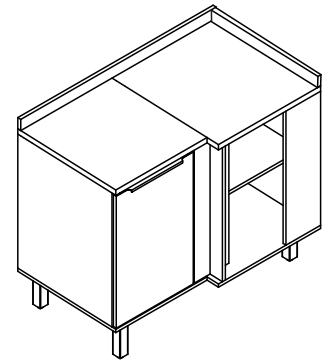



Esquerdo/Izquierdo

Nº	CÓDIGO ASSISTÊNCIA	NOME DA PEÇA/DESCRIPCIÓN PIEZAS	MEDIDAS (mm)	QTD.	CÓDIGO DAS PEÇAS/ CÓDIGO PIEZAS		
					FREIJÓ/FREIJÓ	FREIJÓ/NERO	FREIJÓ/JADE
01	BTO04.01.01	Base inferior/Base inferior	461x516x15	01	209041	209041	209041
02	BTO04.01.00	Base inferior/Base inferior	516x576x15	01	209039	209039	209039
03	BTO04.18.00	Lateral menor/Lateral menor	710x576x15	01	209037	209037	209037
04	BTO04.17.00	Lateral maior/Lateral mayor	710x496x15	01	209036	209036	209036
05	BTO04.25.00	Porta balcão/Puerta	702x376x15	01	209110	209117	209029
06	BTO04.33.01	Tampo/Tapa	516x461x22	01	209046	209046	209046
07	BTO04.33.00	Tampo/Tapa	516x576x22	01	209045	209045	209045
08	BTO04.06.00	Ripa batente/Travesaño	710x65x15	01	209038	209038	209038
09	BTO04.28.00	Ripa sustentação/Travesaño	947x50x15	02	209043	209043	209043
10	BTO04.28.01	Ripa balcão/Travesaño	947x50x15	01	209044	209044	209044
11	BTO04.02.00	Prateleira interna/Repisa	573x484x15	01	209042	209042	209042
12	BTO04.13.00	Forro balcão/Revés	724x474x2.5	02	209047	209047	209047
13	BTO04.06.01	Ripa batente/Travesaño	710x175x15	03	209040	209040	209040
14	BTO04.51.00	Roda tampo/Roda tampo	977x60x22	01	209048	209048	209048
15	BTO04.51.01	Roda tampo/Roda tampo	551x60x22	01	209049	209049	209049

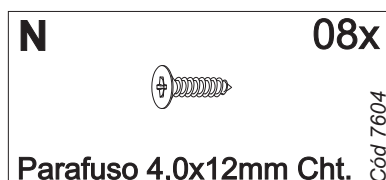
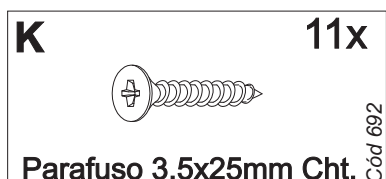
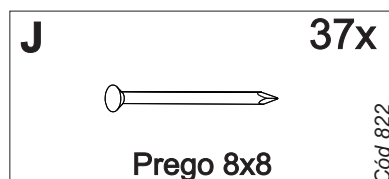
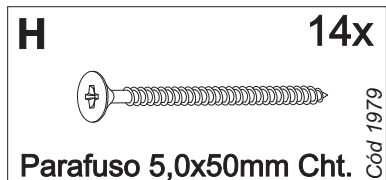
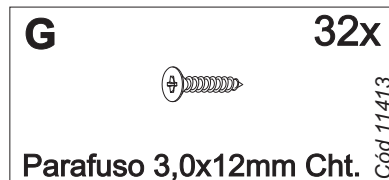
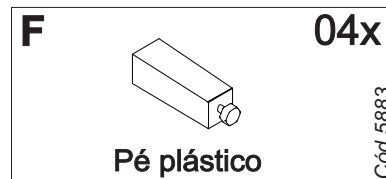
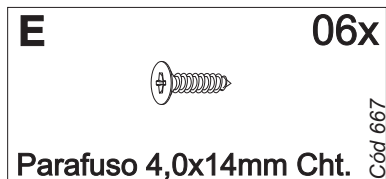
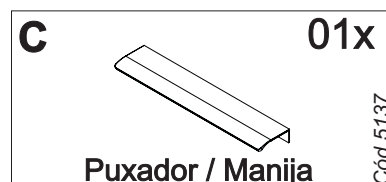
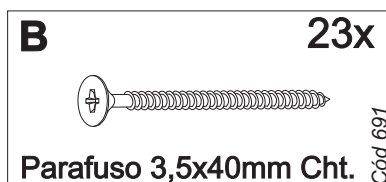





Ferragens/Herrajes



 *Usar os parafusos (K) para unir este módulo a outro. 
 Usar los tornillos (K) para unirse este módulo a otro.

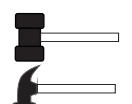

Medidas em mm

		 1:00			 Giz para madeira	Produto para ser aplicado em caso de riscos na superfície
---	---	--	---	---	---	---

Pré-Montagem/Preparación Piezas

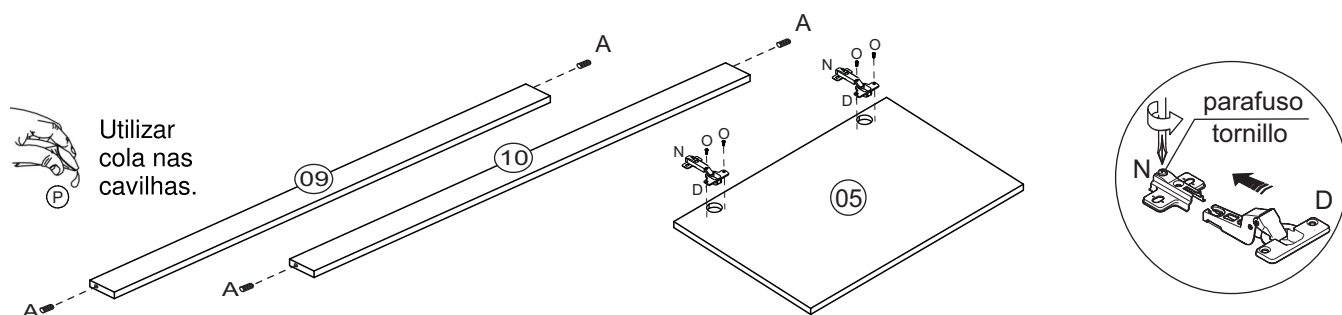

Montagem/Montaje

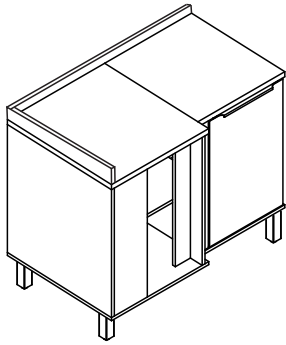

Direito/Derecho

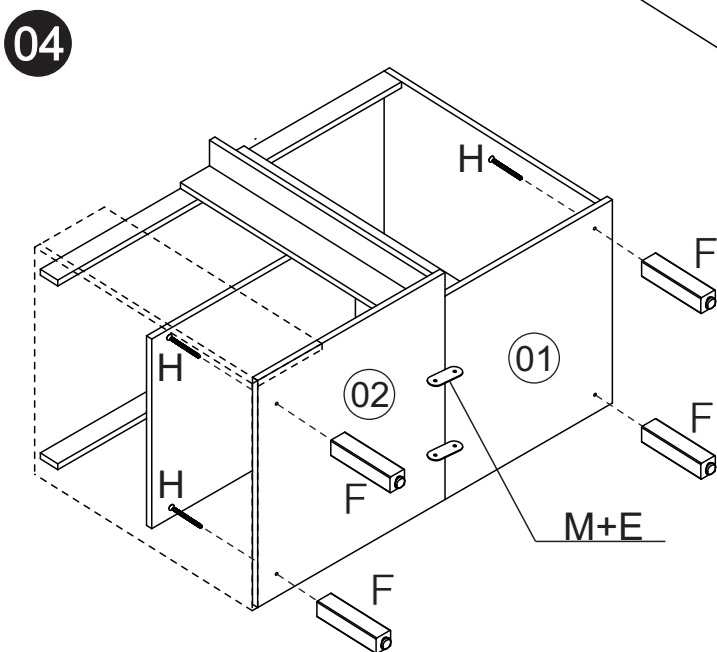
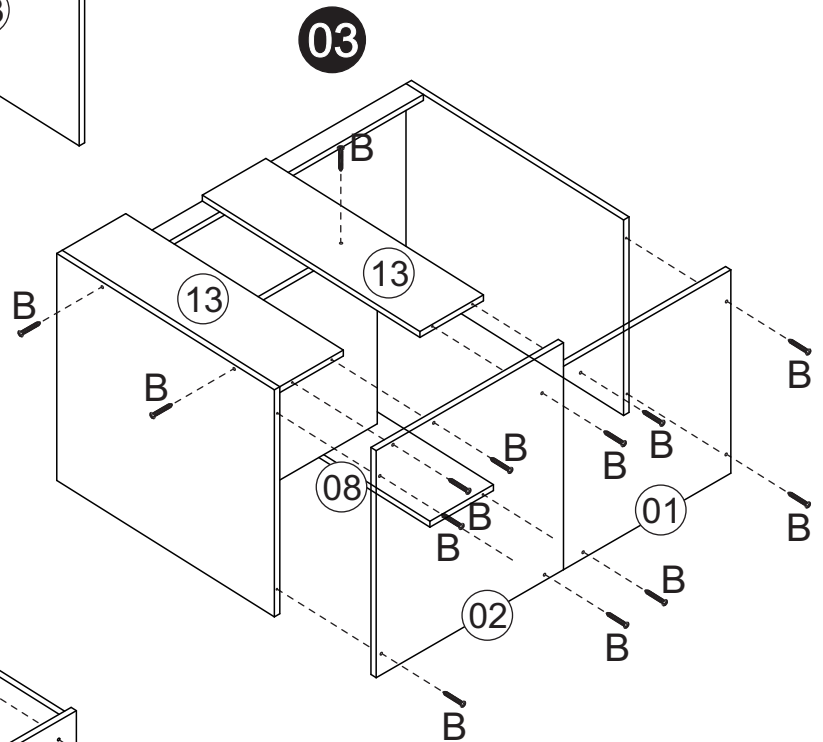
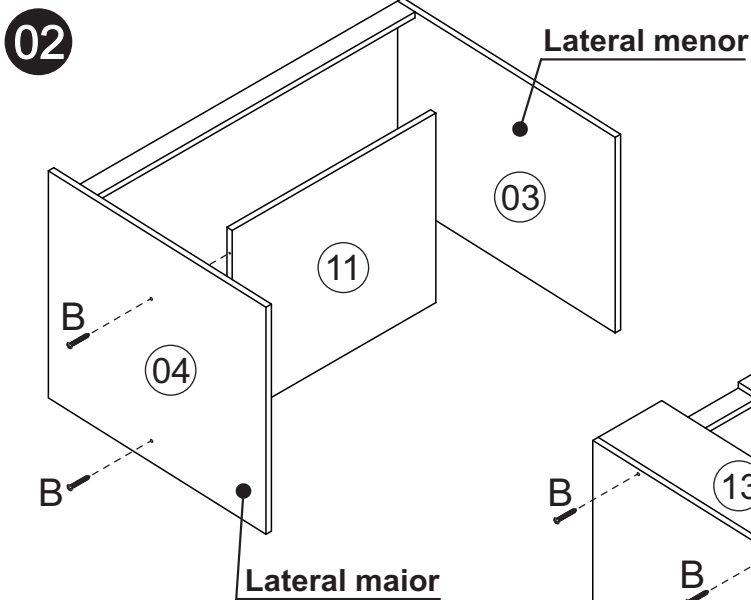
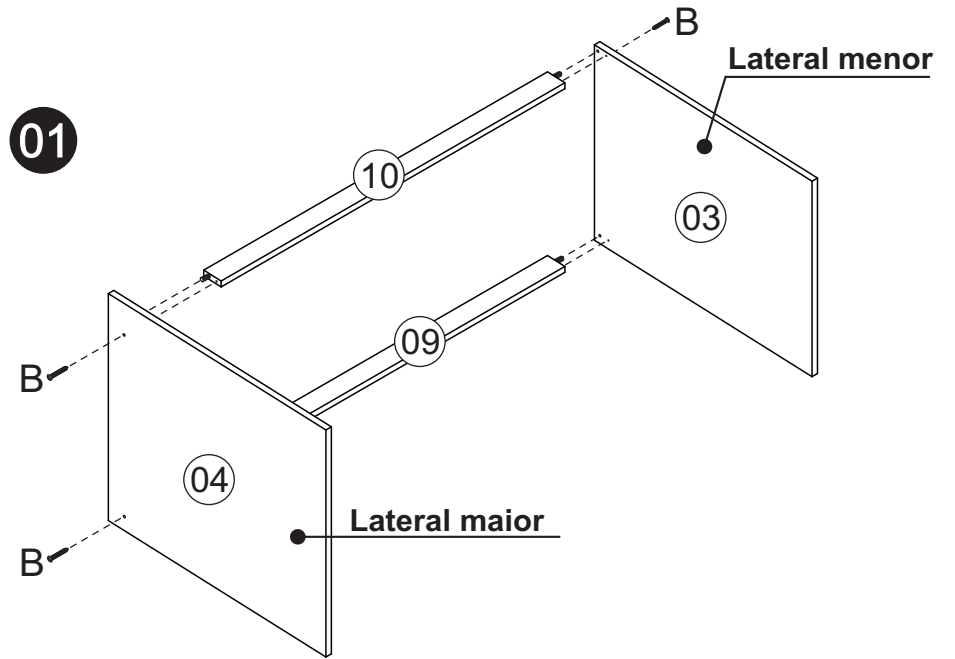

Montagem/Montaje

05

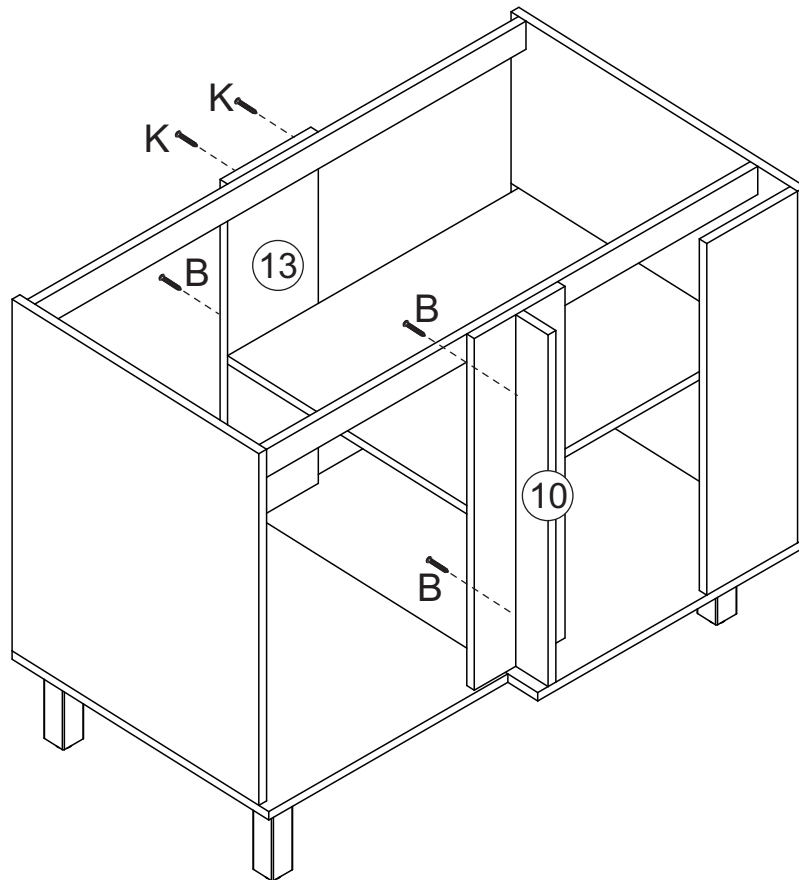

Obs: Roda tampo fixado no tampo com parafuso 5x50

06

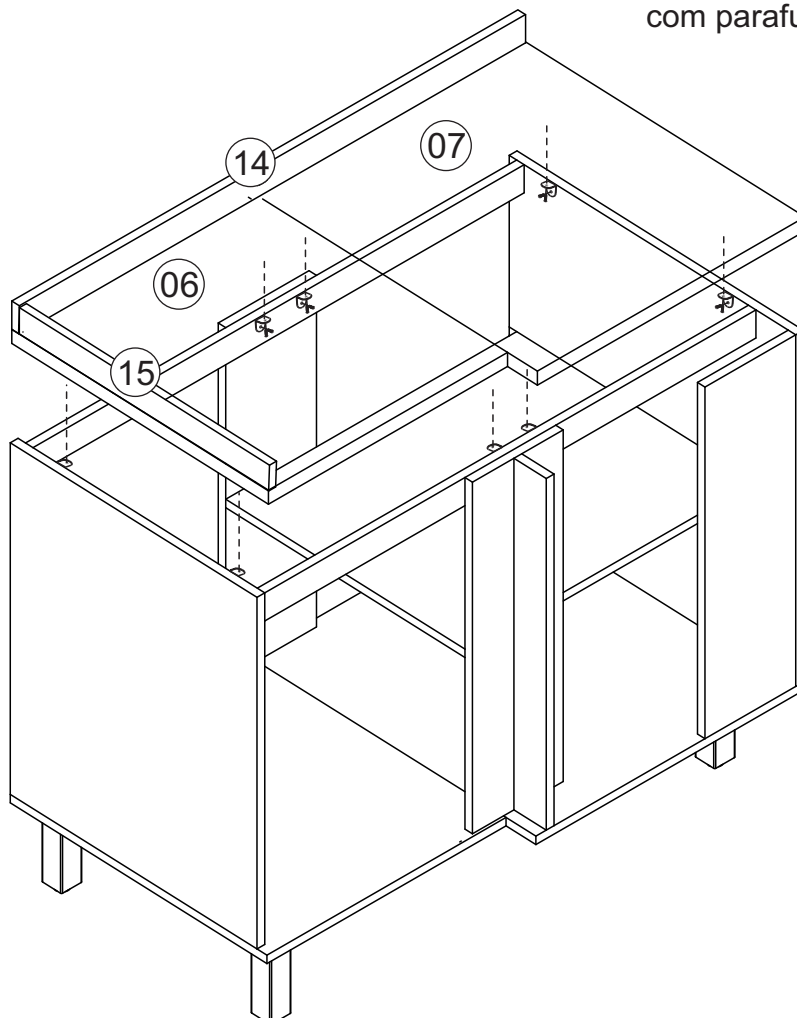

Montagem/Montaje

07

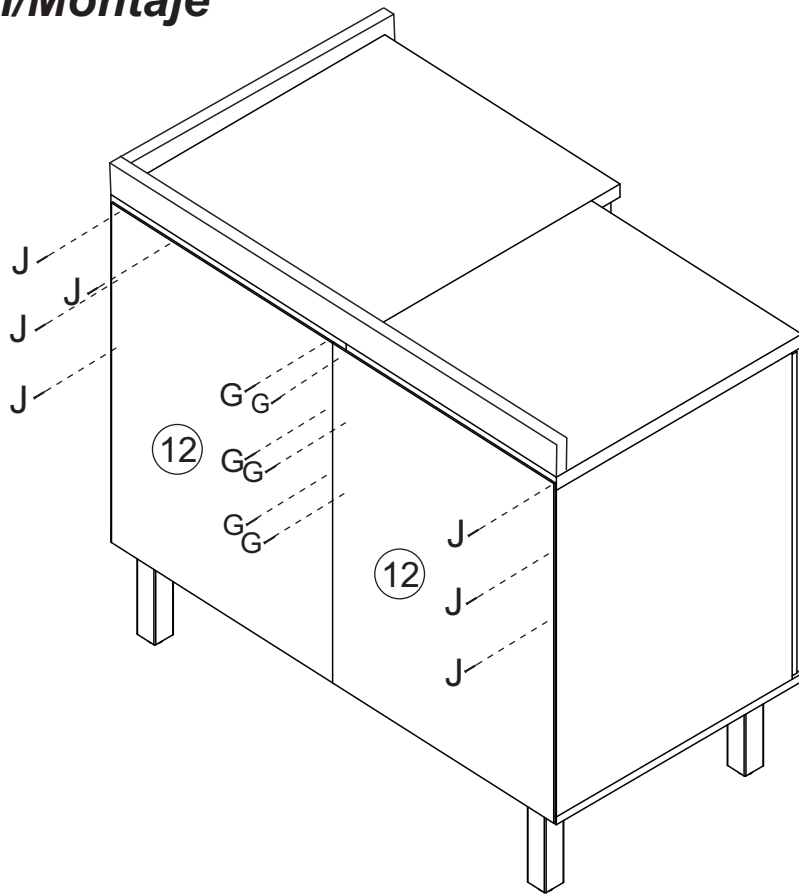

08

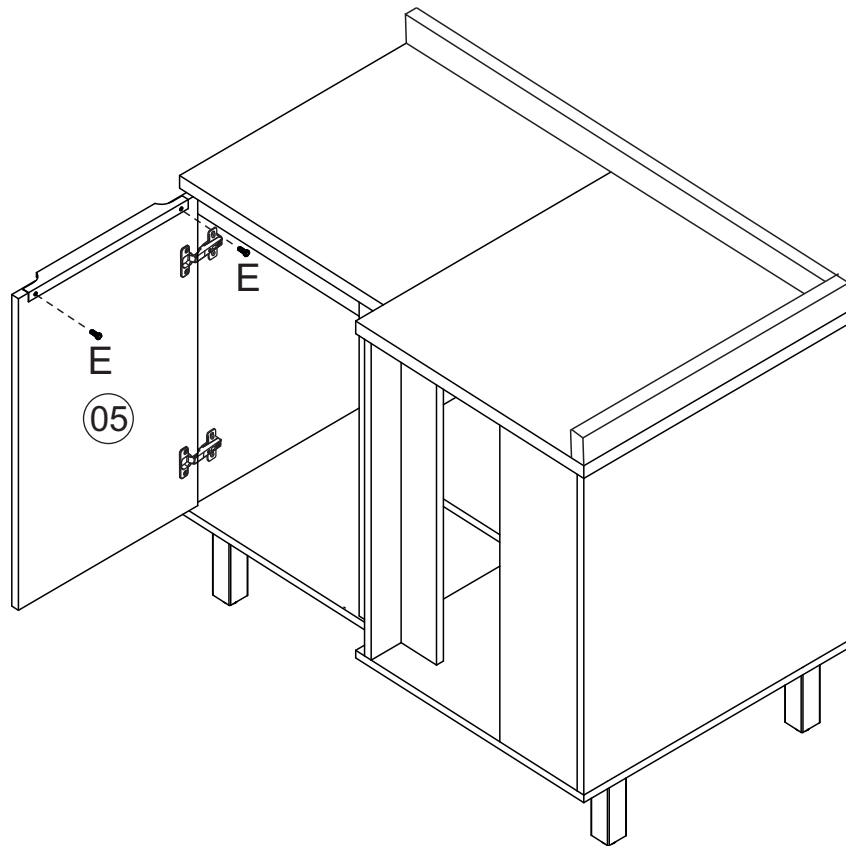
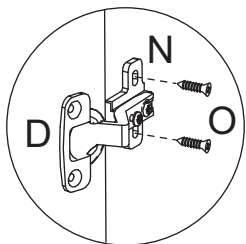

Montagem/Montaje

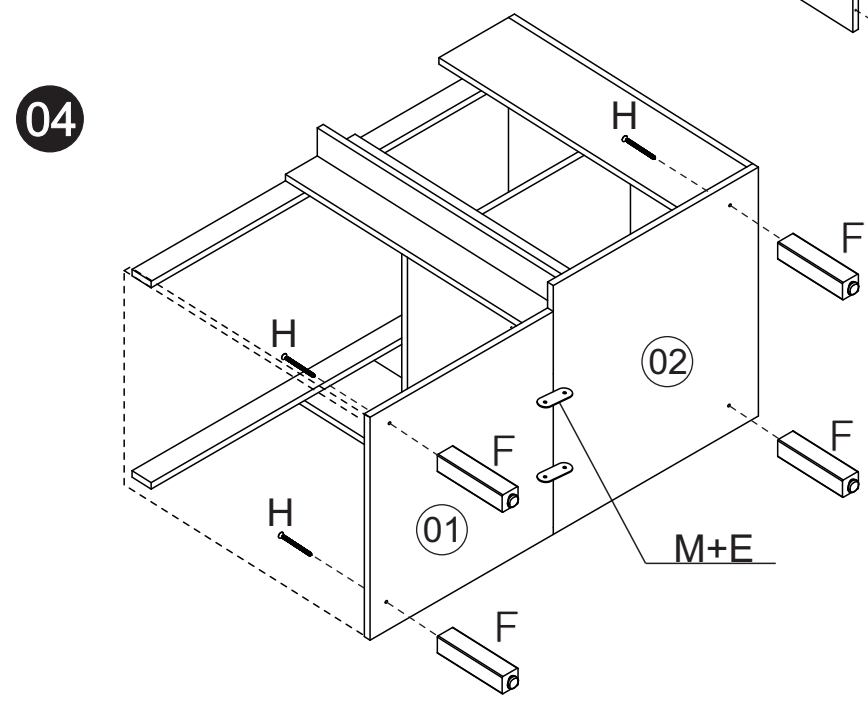
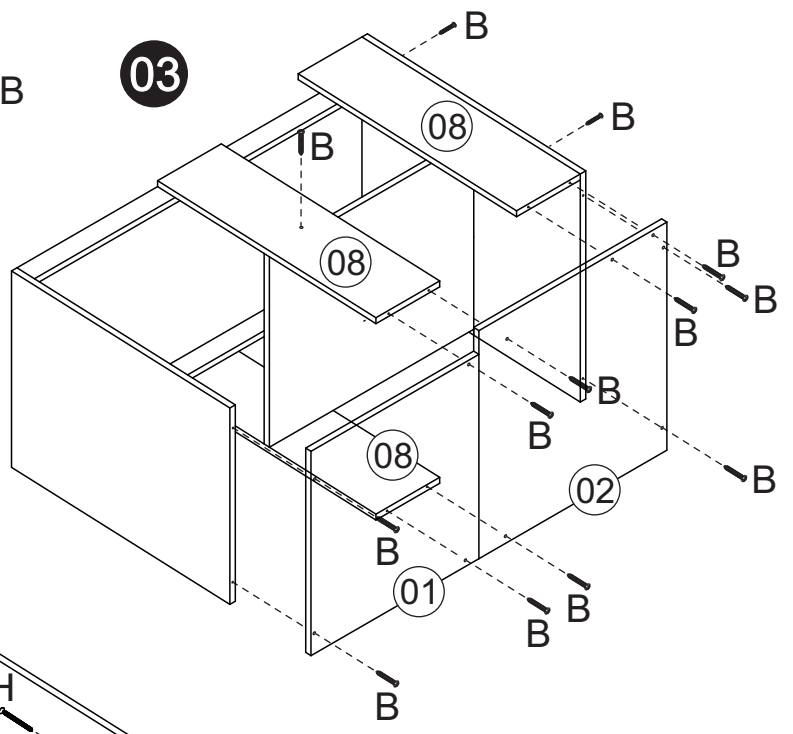
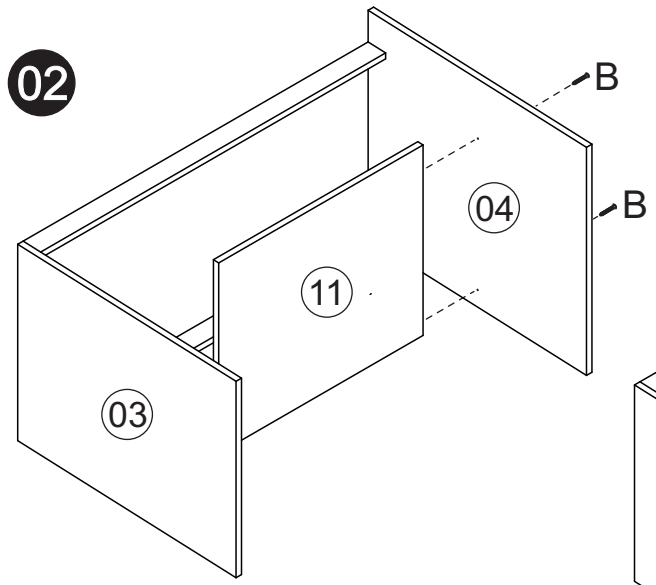
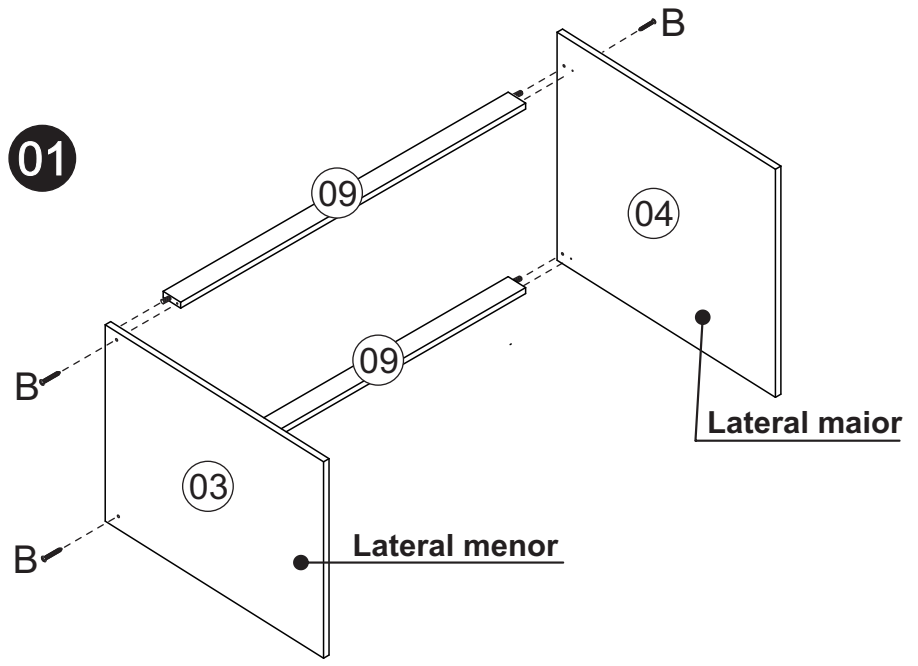
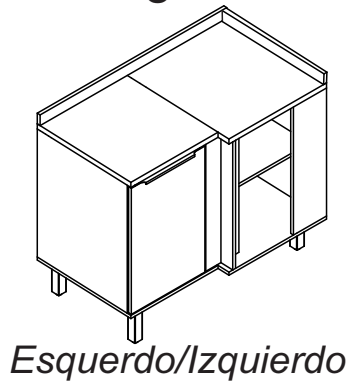

Montagem/Montaje

05

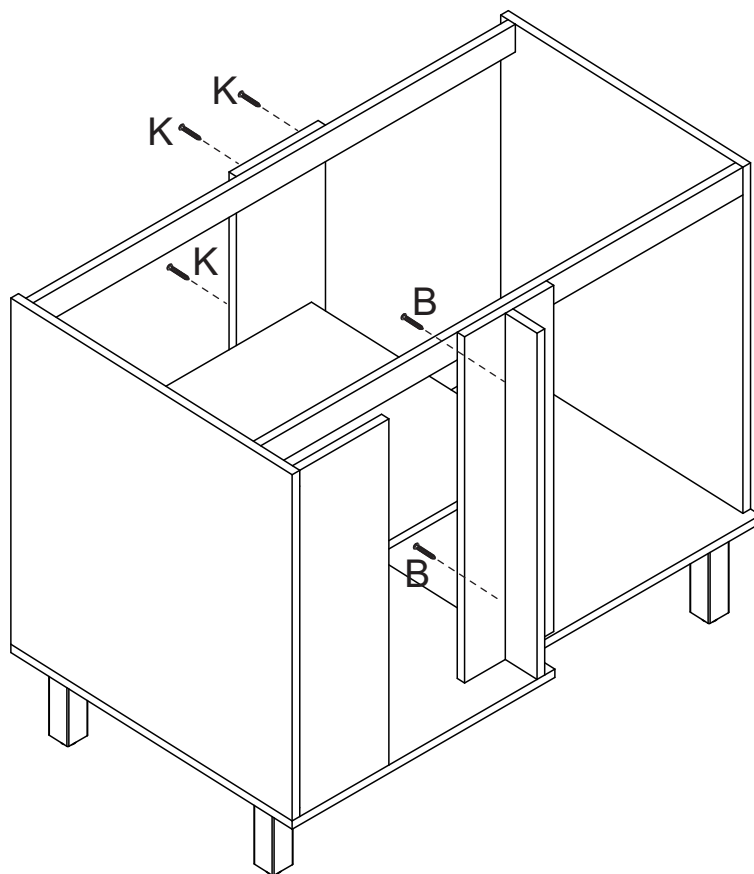

06

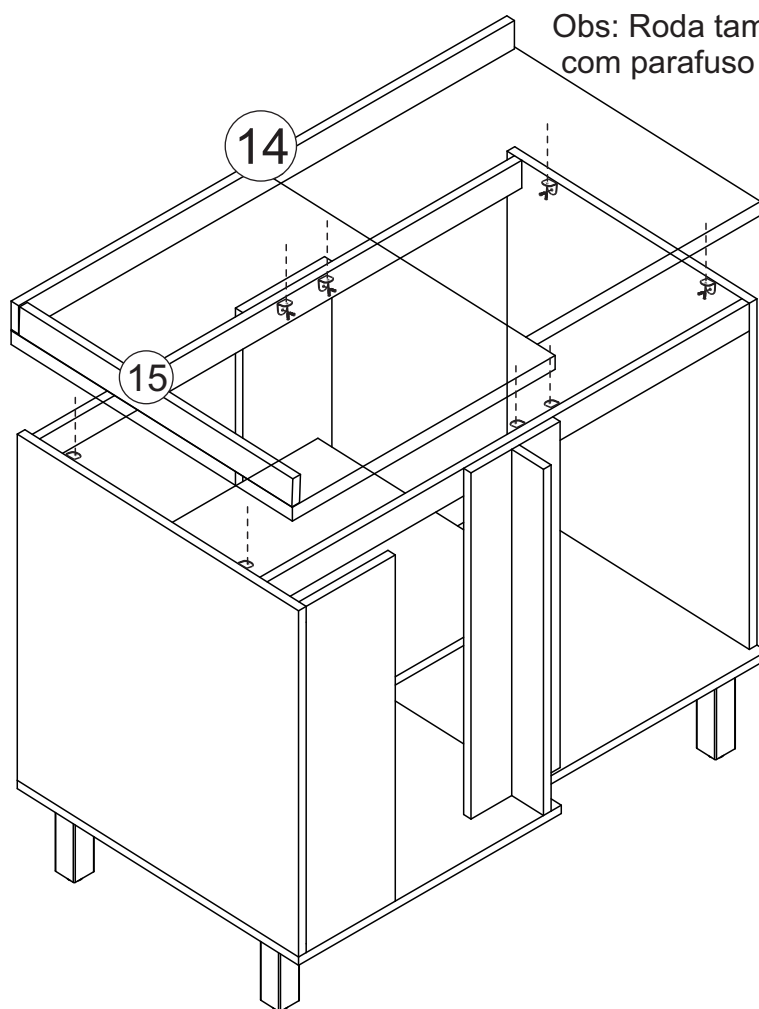

Obs: Roda tampo fixado no tampo com parafuso 5x50

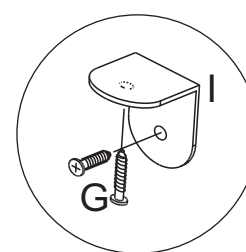

Montagem/Montaje

07

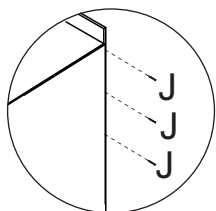

*Colocar um prego (J)
a cada 100mm.

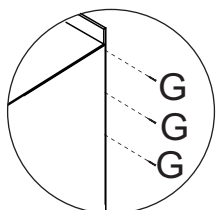

*Colocar um parafuso (G)
a cada 100mm.

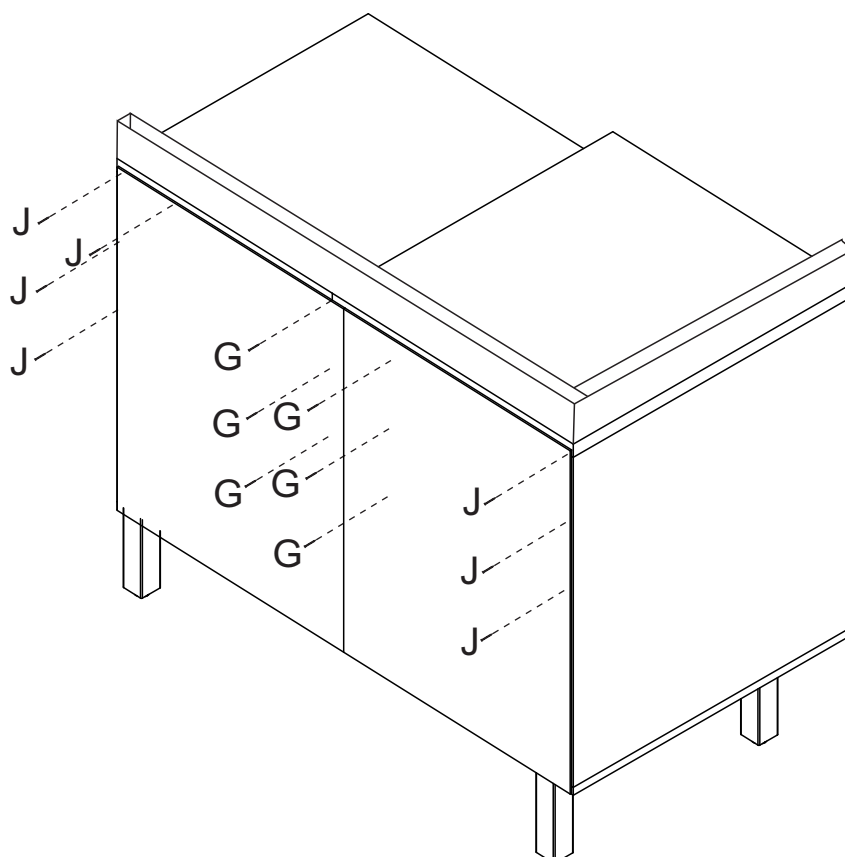

08

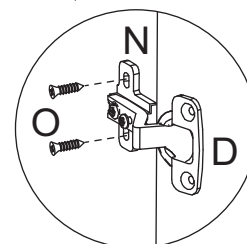
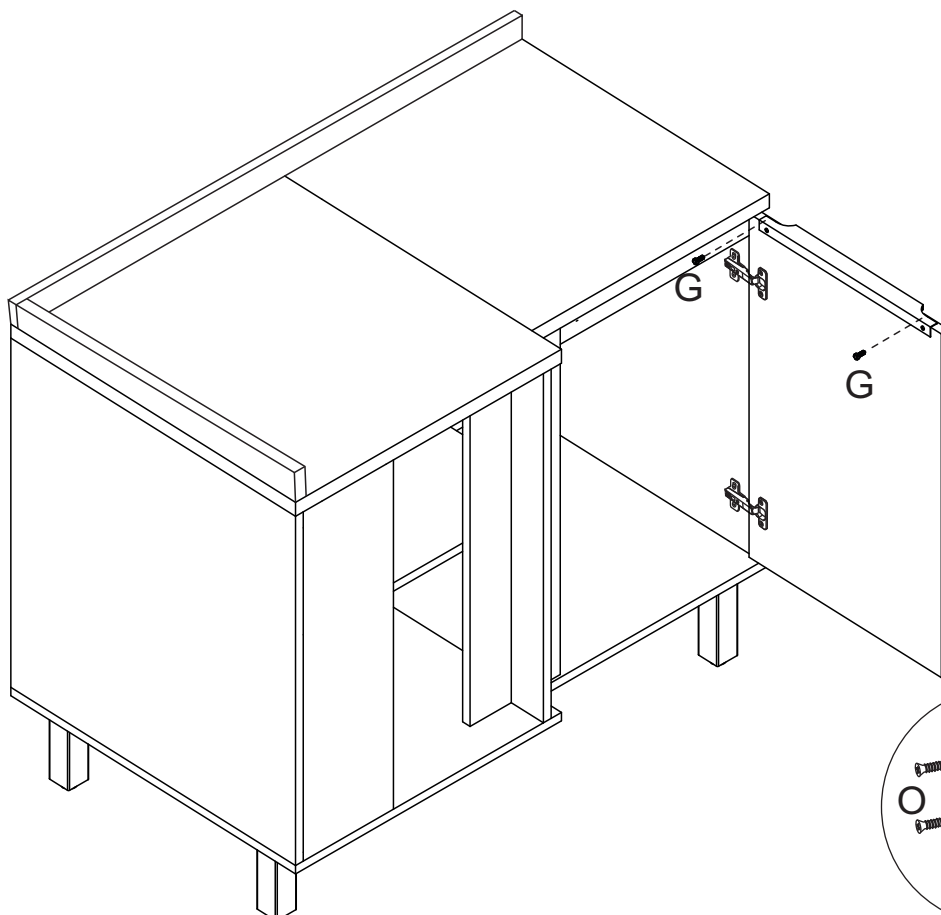

Limpeza/Limpieza

- ≠ Use um pano levemente umedecido com água, seguido de pano seco.
- ≠ Use solamente un paño húmedo con agua y después un paño seco.
- ≠ Nunca utilize produtos químicos ou abrasivos.
- ≠ No utilice productos químicos o abrasivos.