

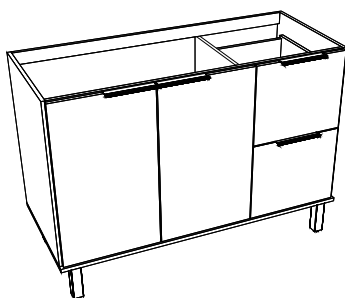

mxmóveis

Rodovia SC-492 - Km 10 - B. Industrial  
89905-000 - Bandeirante - SC  
Fone: (49) 3622-4549  
e-mail: mxmoveis@mxmoveis.com.br



**Ref. BTO03**

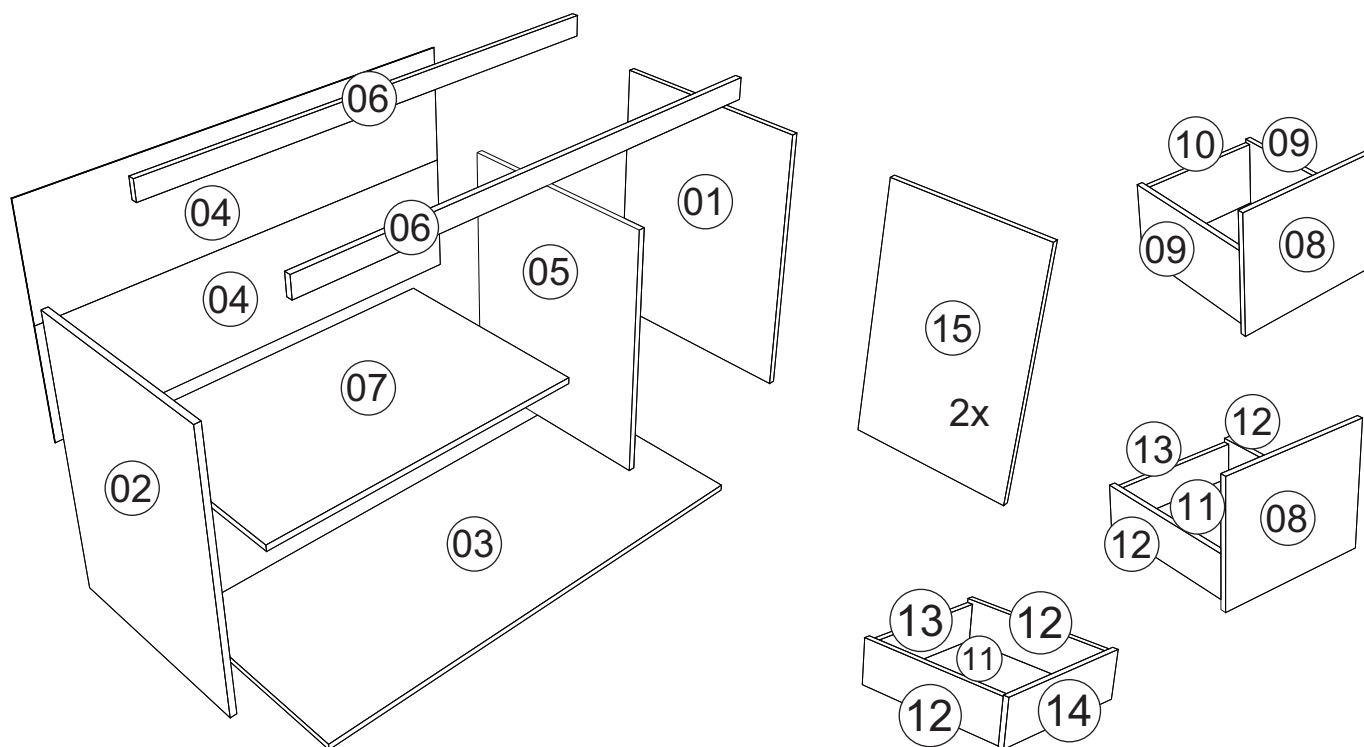

**Balcão 1200 2P 3G**  
**Cozinha/Cocina**  
**TOSCANA**



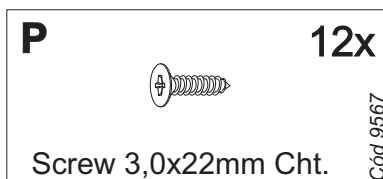
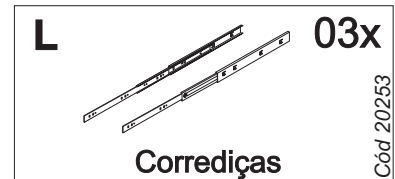
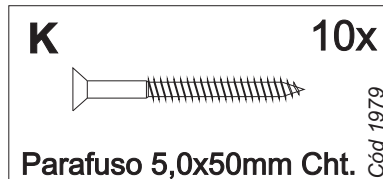
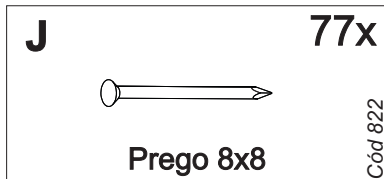
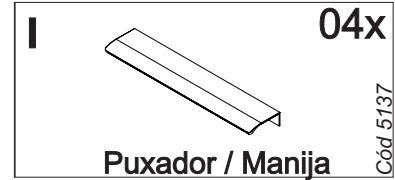
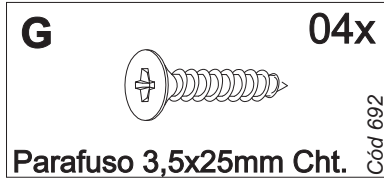
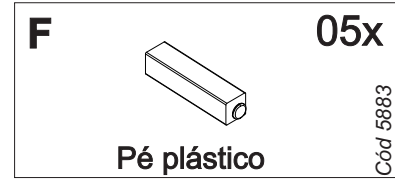
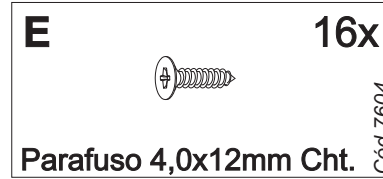
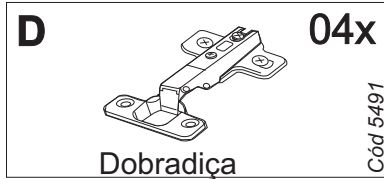
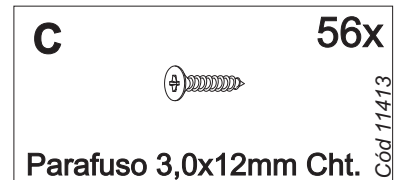
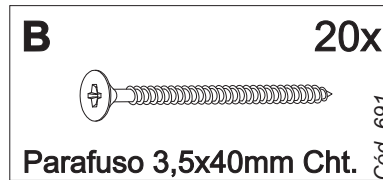
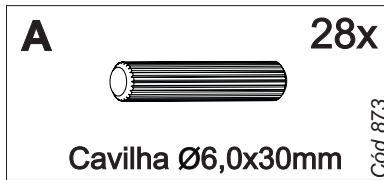

Nº	CÓDIGO ASSISTÊNCIA	NOME DA PEÇA/DESCRIPCIÓN PIEZAS	MEDIDAS (mm)	QTD	CÓDIGO DAS PEÇAS/ CÓDIGO PIEZAS		
					FREIJÓ/FREIJÓ	FREIJÓ/NERO	FREIJÓ/JADE
01	BTO03.17.00	Lateral externa direita/Lateral derecha	710x496x15	01	208894	208894	208894
02	BTO03.18.00	Lateral externa esquerda/Lateral izquierda	710x496x15	01	208895	208895	208895
03	BTO03.01.01	Base inferior/Base inferior	1200x516x15	01	208907	208907	208907
04	BTO03.13.00	Forro/Revés	1190X337x2.5	02	208900	208900	208900
05	BTO03.20.00	Lateral interna/Lado interno	660x496x15	01	208896	208896	208896
06	BTO03.28.00	Ripa balcão frontal/Travesaño	1170x50x15	02	208897	208897	208897
07	BTO03.02.00	Base interna/Base pequena	795x360x15	01	208899	208899	208899
08	BTO03.14.00	Frente gaveta/Frente cajón	370x349x15	02	208986	209123	208975
09	BTO03.15.00	Lateral gaveta/Lateral cajón	350x200x15	02	208901	208901	208901
10	BTO03.29.00	Ripa traseira gaveta/Trasero cajón	306x180x15	01	208903	208903	208903
11	BTO03.34.00	Forro gaveta/Revés cajón	330x355x15	03	208906	208906	208906
12	BTO03.15.01	Lateral gaveta/Lateral cajón	350x100x15	04	208902	208902	208902
13	BTO03.29.01	Ripa traseira gaveta/Trasero cajón	306x80x15	02	208904	208904	208904
14	BTO03.14.01	Frente gaveta/Frente cajón	340x130x15	01	208905	208905	210015
15	BTO03.25.00	Porta balcão/Puerta	702x401x15	02	208985	209119	208974
16	BTO03.28.01	Ripa balcão frontal/Travesaño	1170x50x15	01	208898	208898	208898

# Ferragens/Herrajes



 \*Usar os parafusos (G) para unir este módulo a outro. Usar los tornillos (G) para unirse este módulo a otro. 

**\* Em caso de aquisição do tampo e roda tampo \***

 Este kit de ferragem possui 03 unidades a mais do parafuso (K), 8 (C) e 4 unidades do item (H). 



Medidas em mm

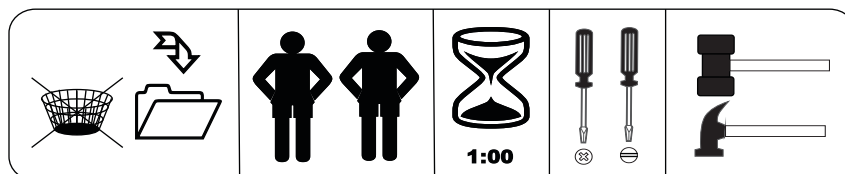

Produto para ser aplicado em caso de riscos na superfície

# Pré-Montagem/Preparación Piezas

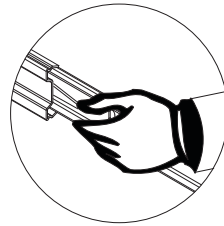
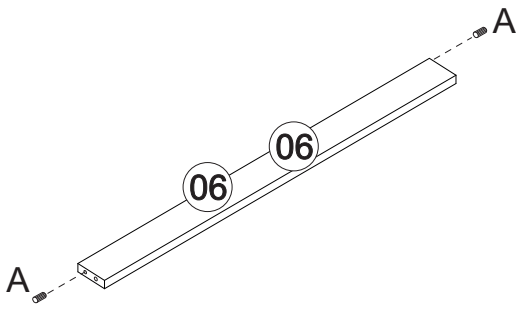

Soltar as partes da corredeira

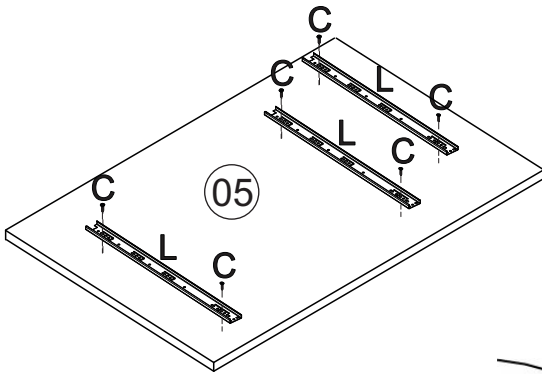
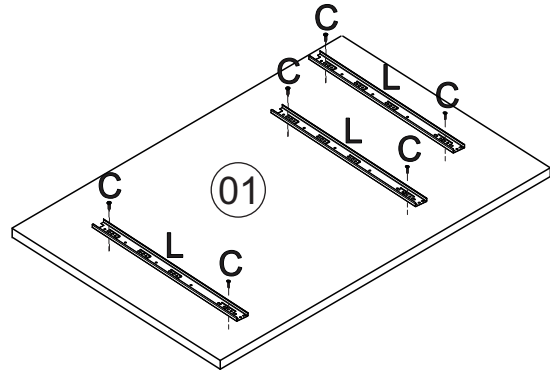
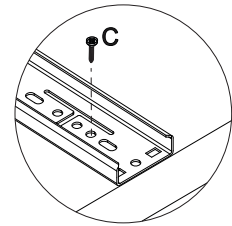

Utilizar cola nas cavilhas.

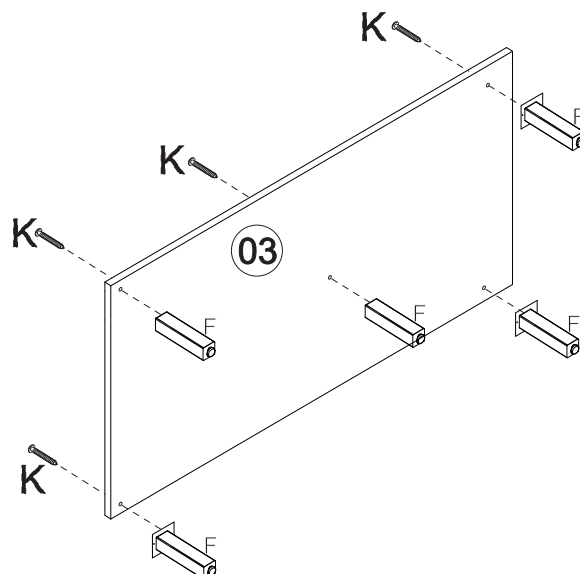
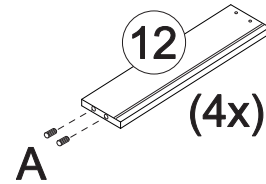
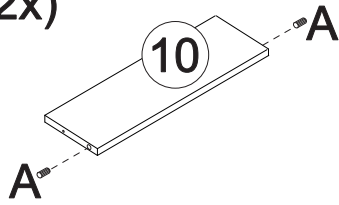
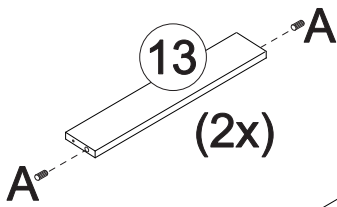
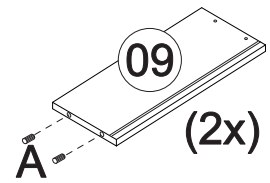

**01** Montagem/Montaje

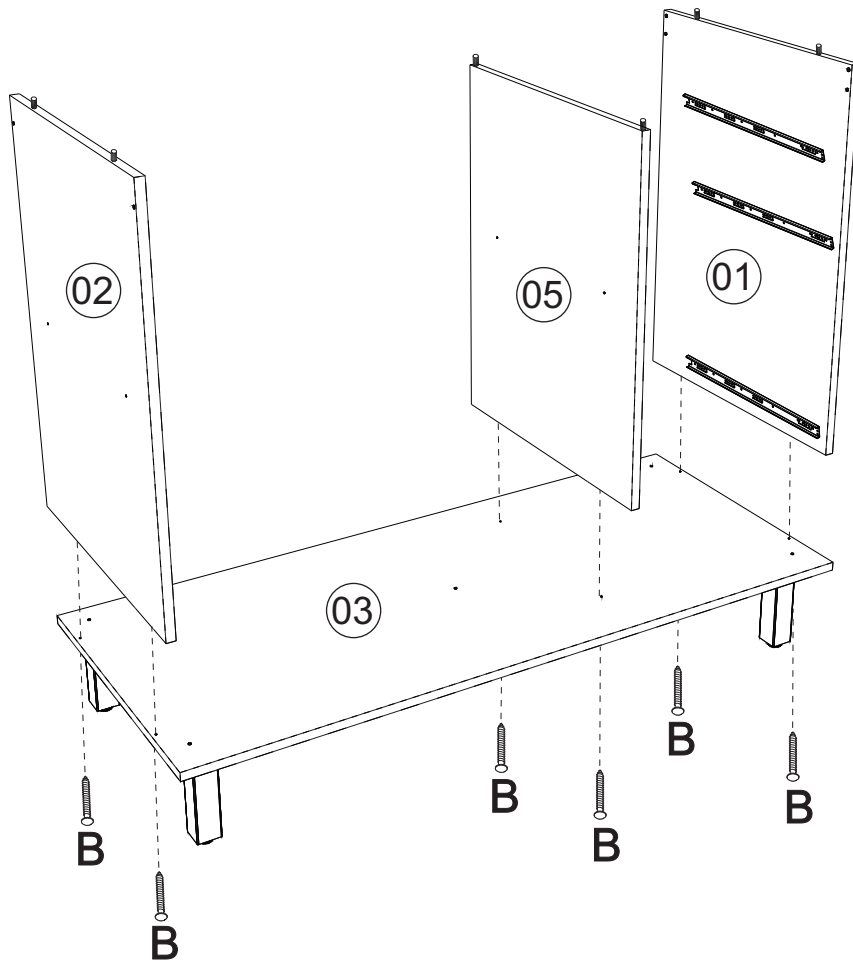

**02** Montagem/Montaje

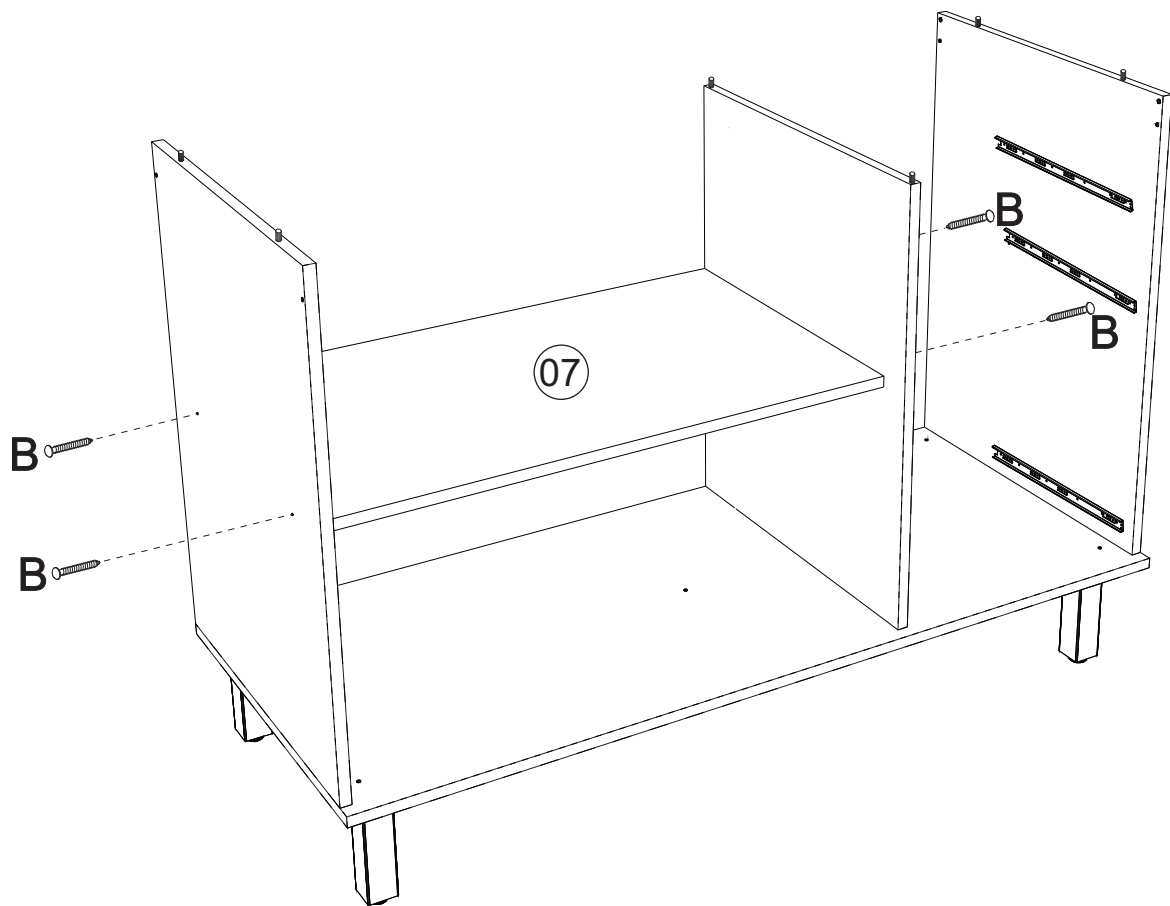

### 03 Montagem/Montaje

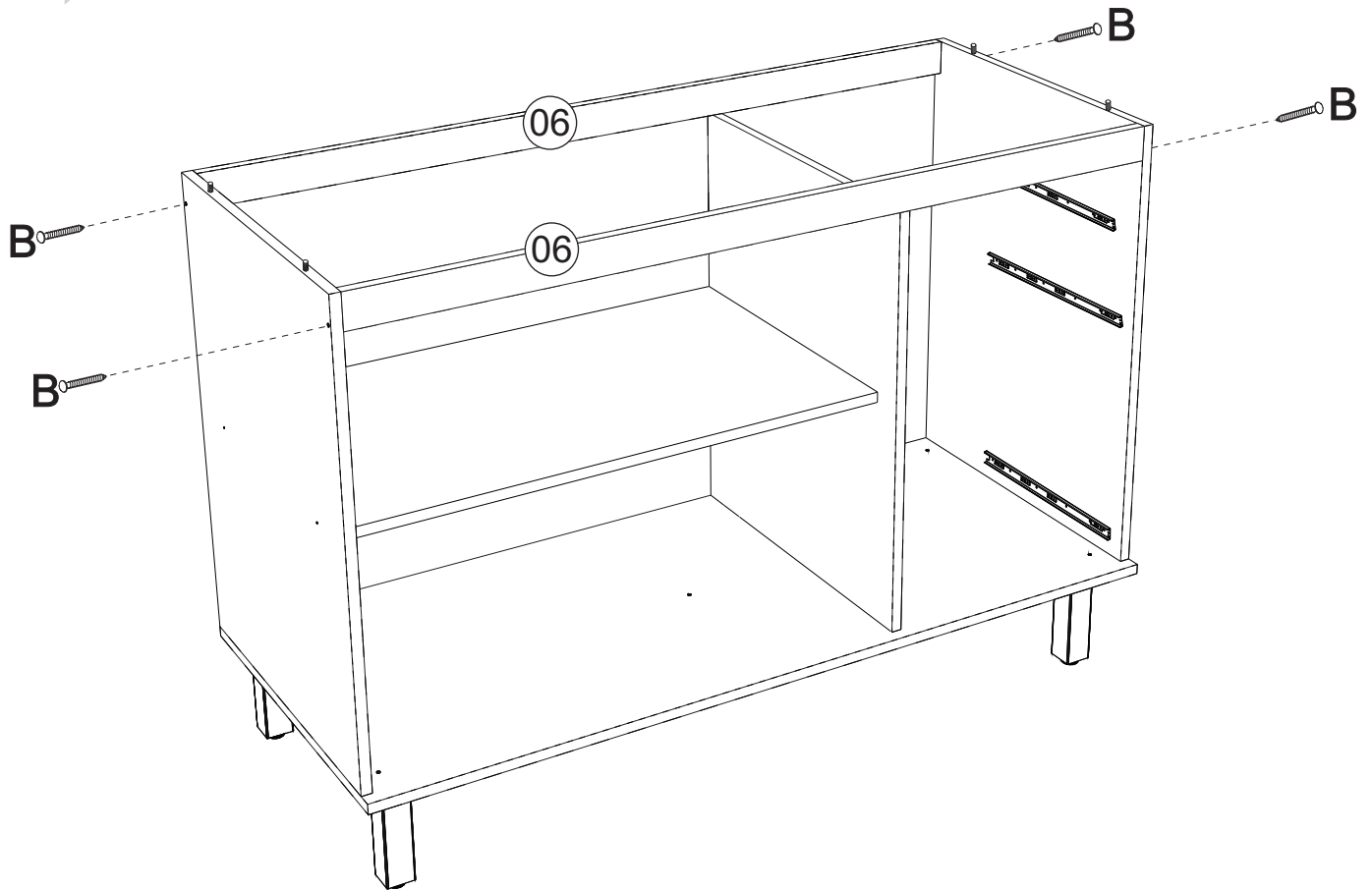

### 04 Montagem/Montaje

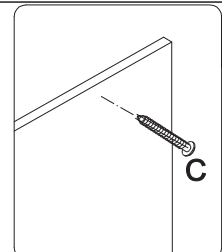
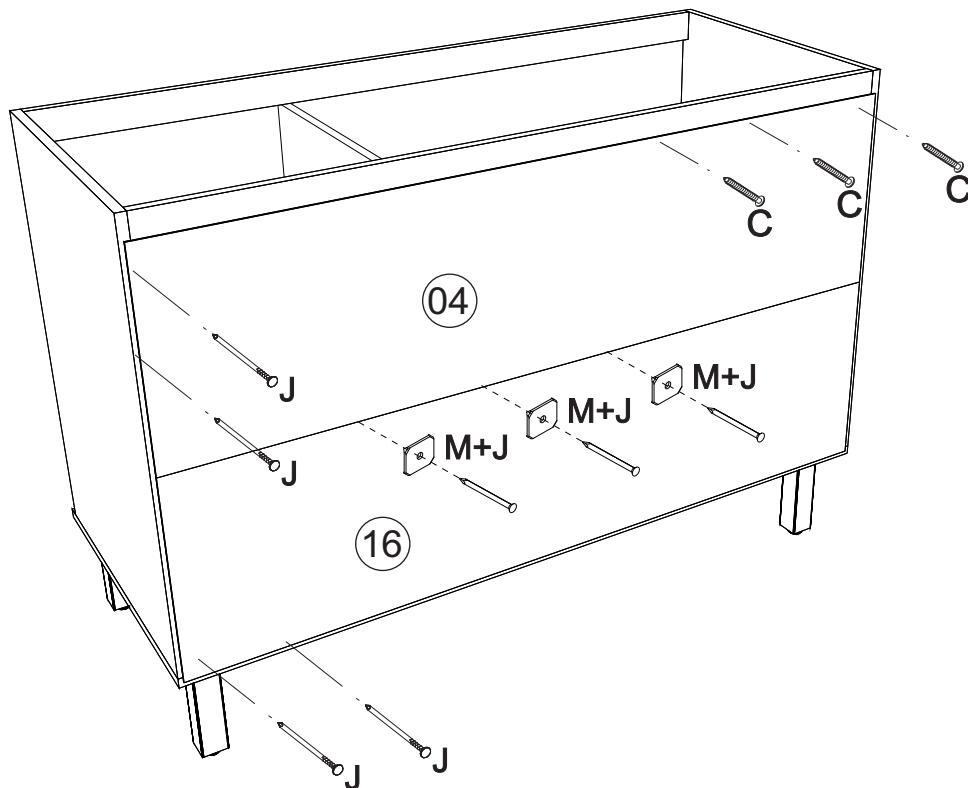

\*Colocar um parafuso (C) a cada 100mm

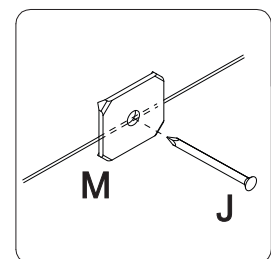

\*Colocar o prego (J) e a junção (M) a cada 100mm

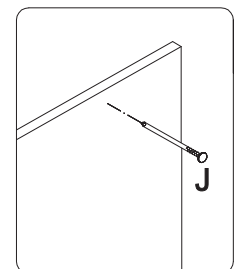

\*Colocar um prego (J) a cada 100mm

## 05 Montagem/Montaje

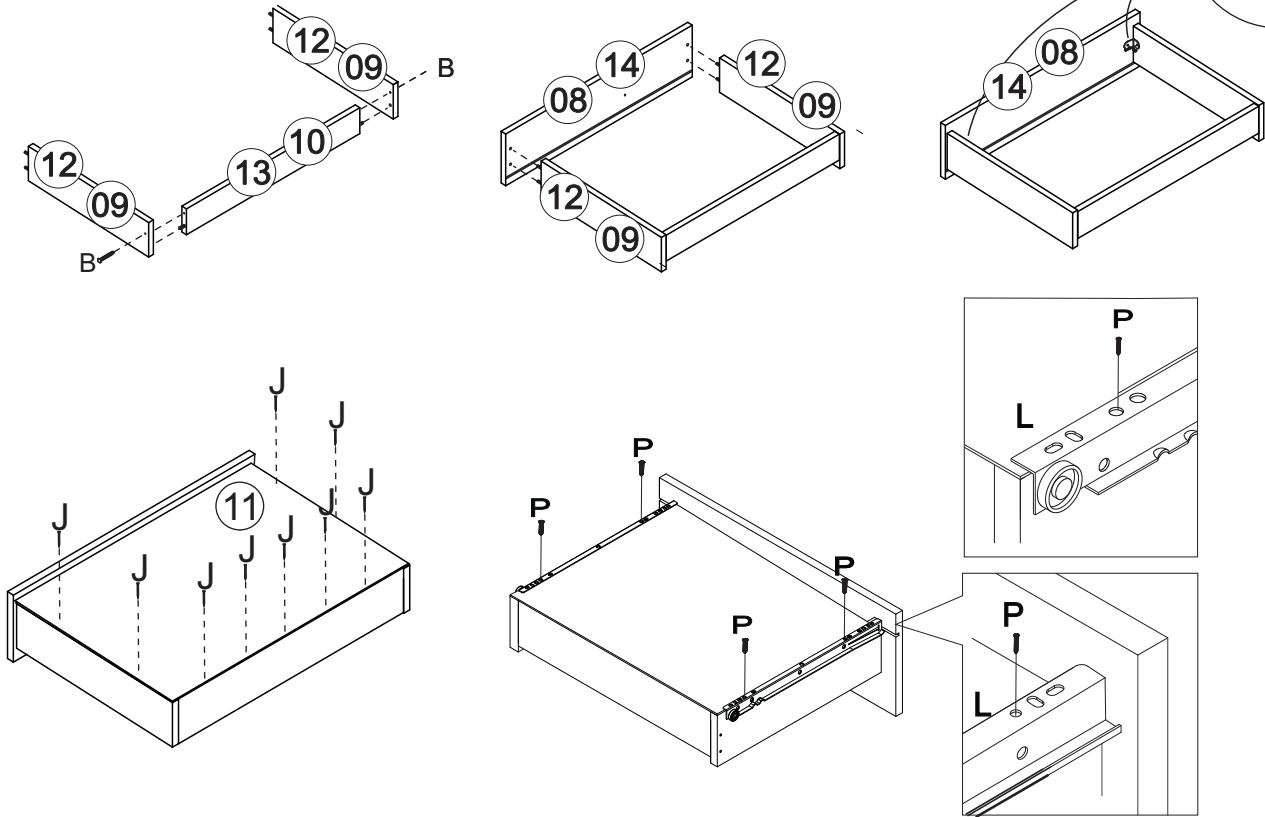
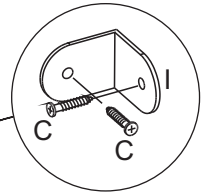

## 06 Montagem/Montaje

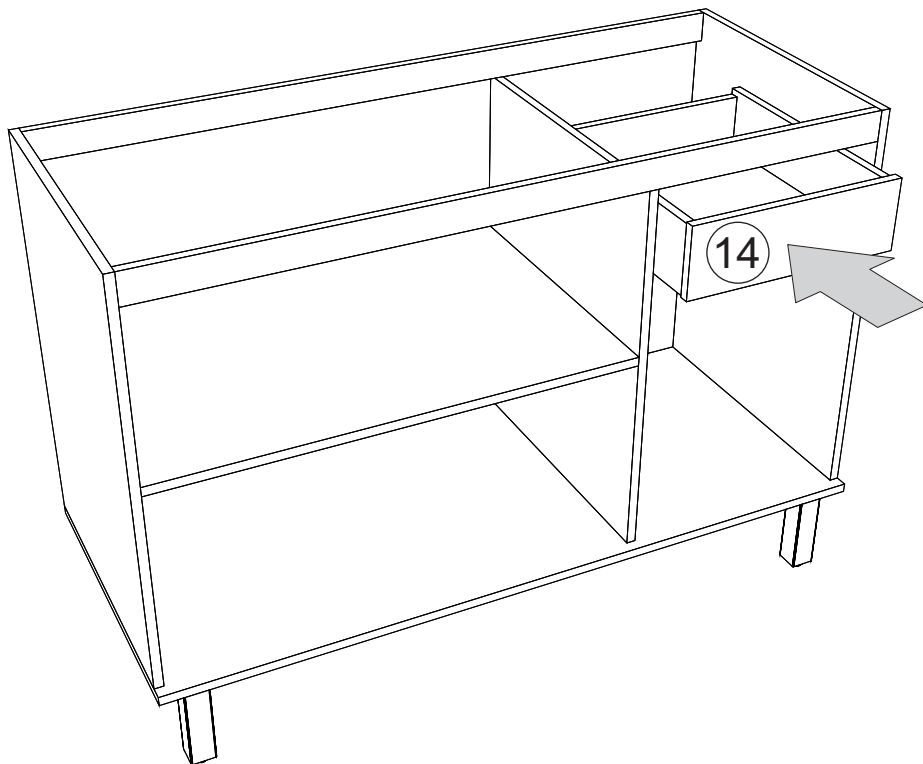

## 07 → Montagem/Montaje

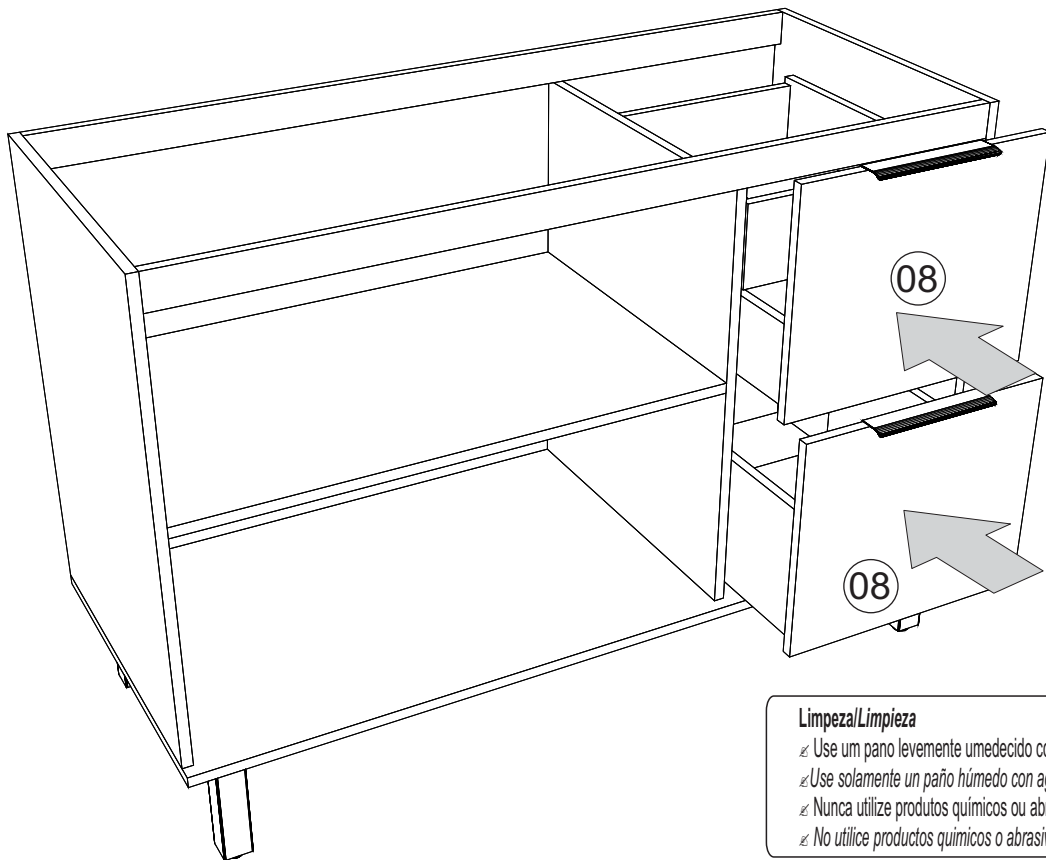

## 08 → Montagem/Montaje

