

Instruções de montagem

Assembly Instructions / Instrucciones de Montaje

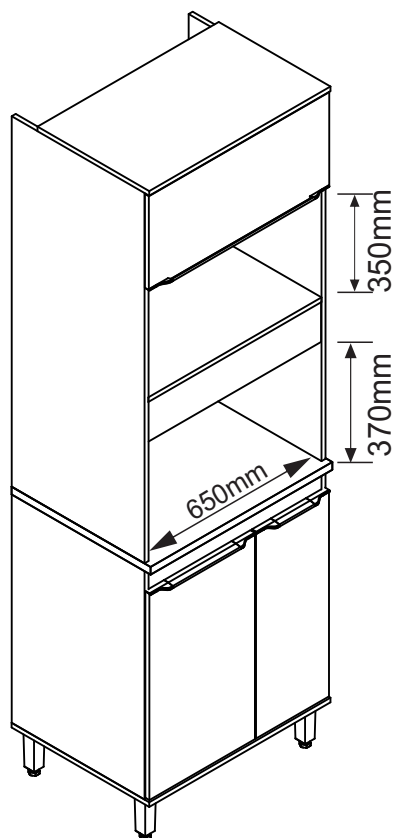

PA8502P

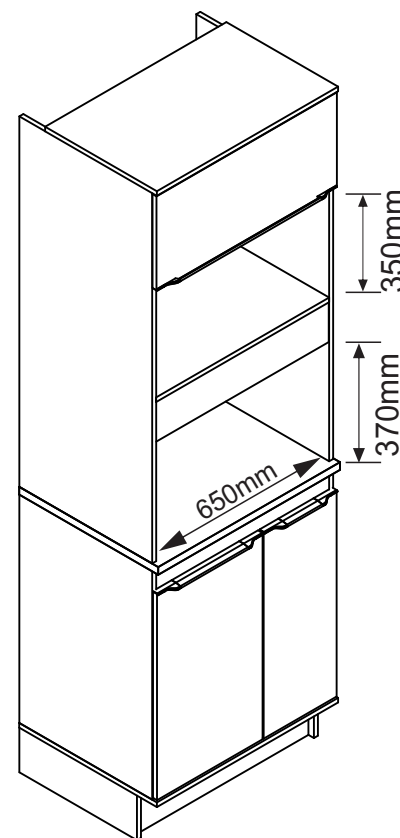

PA8502R

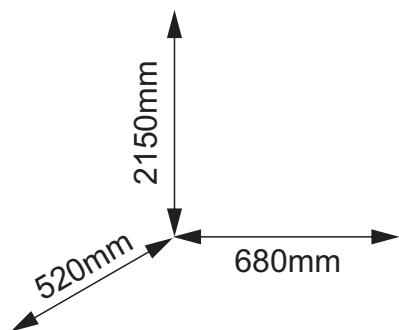

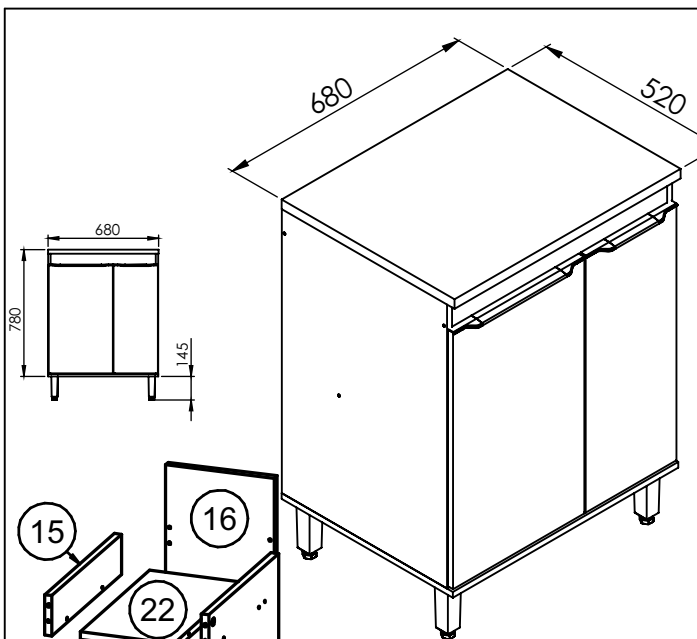

REF	DESC	COMP	LARG	ESP	QTD.
PA8170-01	LATERAL DIR/LADO DERECHO/RIGHT SIDE	740	497	15	1
PA8170-02	LATERAL ESQ/LADO IZQUIERDO/LEFT SIDE	740	497	15	1
PA8170-03	BASE/BASE/BASE	678	515	15	1
PA8170-04	DIVISÃO/DIVISIÓN/DIVISION	665	497	15	1
PA8170-05	PRATELEIRA/ESTANTE/SHELF	383	350	15	1
PA8170-06	TRAVESSA/TRAVESAÑO/PLATTER	648	75	15	2
PA8170-07	TAMPO/TAPA/TOP	680	520	25	1
PA8170-11	FRENTE PORTA COND/FRENTE/FRONT	668	273	15	1
PA8170-12	PORTA/PUERTA/DOOR	668	395	15	1
PA8170-14	LAT MAIOR PTA COND/LADO MAS GRANDE/LARGE SIDE	380	435	15	1
PA8170-15	LATERAL PORTA COND/LAT COND/SIDE COND	380	82	15	2
PA8170-16	COSTA PORTA COND/FONDO/BACK	540	224	15	1
PA8170-20	COSTA/FONDO/BACK	670	350	3	2
PA8170-22	FUNDO PTA CONF/BACKGROUND/ANTECEDENTE	193	380	15	2

PA8300-50 Rodape Lateral	440 x 145 x 15	2
PA8300-51 Rodape Frontal 68	647 x 145 x 15	1
PA8300-52 Rodape Traseiro 68	647 x 145 x 15	1

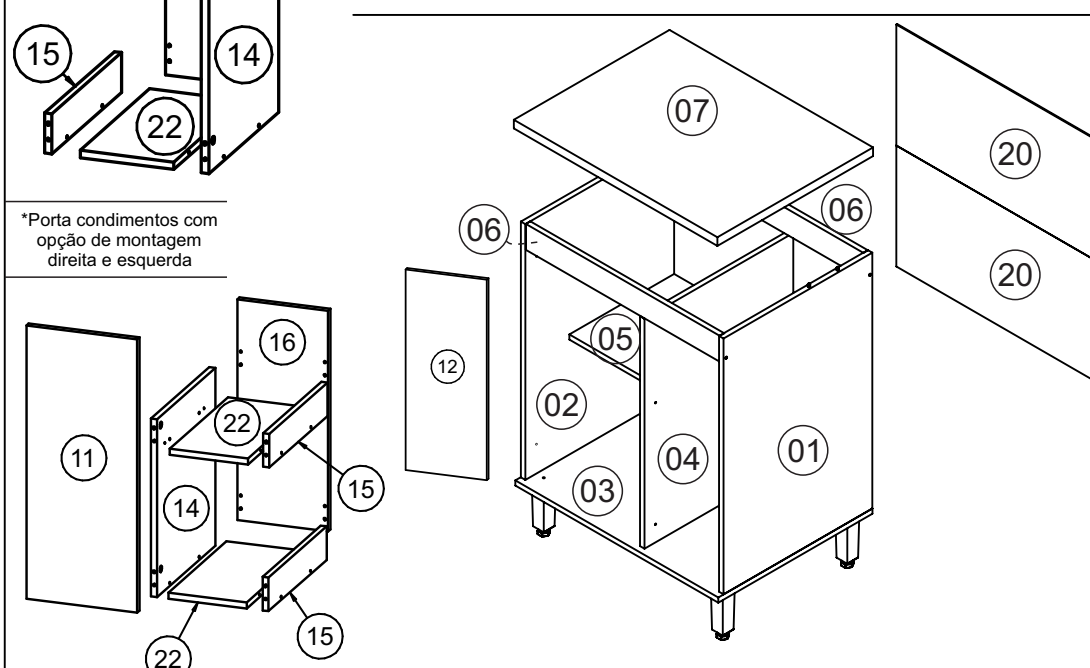

*Porta condimentos com opção de montagem direita e esquerda

LISTA DE ACESSÓRIOS		
COD	DESCRIÇÃO	QTD
A	CAVILHA Ø6X30	8
B	PARAFUSO CC 3,5X14 REBAIXE	8
C	PARAFUSO CC 3,5X40	4
L	CANTONEIRA 18X18	4

FERRAMENTAS NECESSÁRIAS:







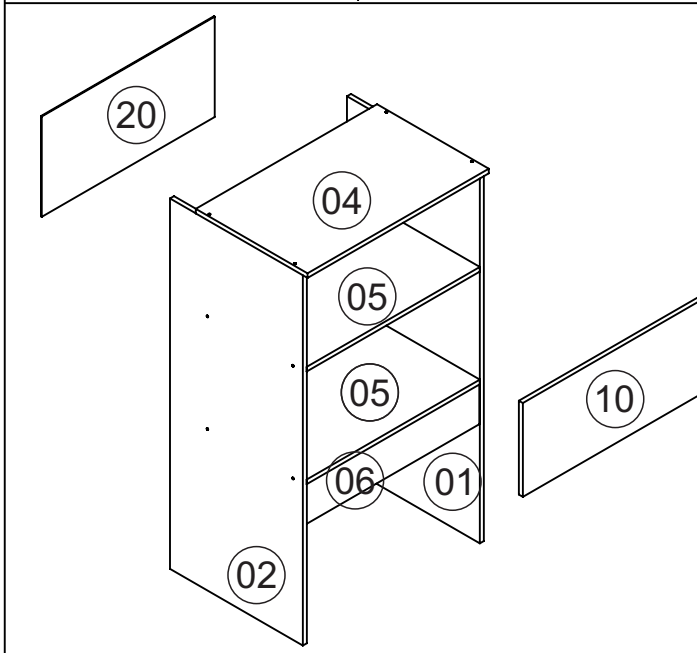
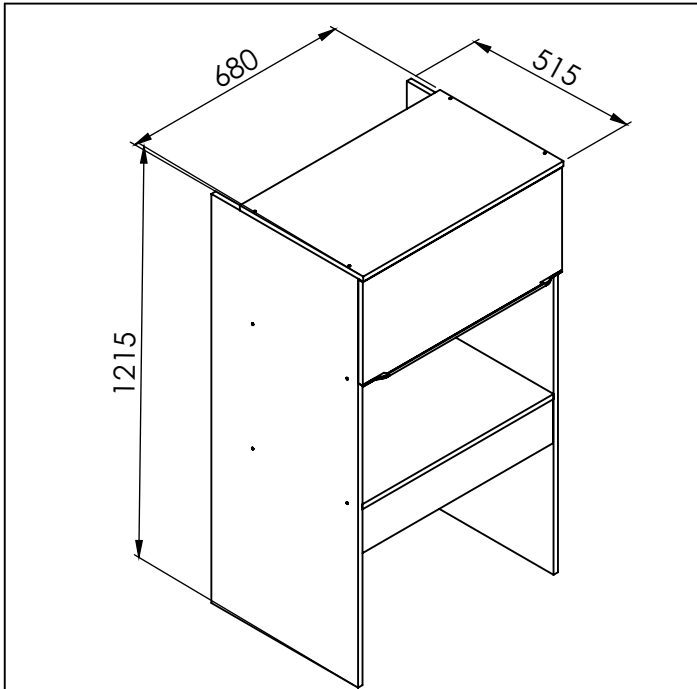







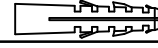
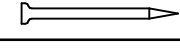

"IMPORTANTE LER COM ATENÇÃO E GUARDAR PARA EVENTUAIS CONSULTAS".

LISTA DE ACESSÓRIOS		
COD	DESCRIÇÃO	QTD
A	CAVILHA Ø6X30 CLAVIJA Ø6X30 WOOD DOWEL Ø6X30	26
B	PARAFUSO CC 4X14 REBAIXE TORNILLO CC 4X14 SCREW CC 4X14	39
C	PARAFUSO CC 4X40 TORNILLO CC 4X40 SCREW CC 4X40	24
CR	CORREDIÇA TELES CORREDERA SLIDE	2
DB	DOD 35 RETA AMORT BISAGRA HINGE	2
F	PARAFUSO CF 4,5X50 TORNILLO CF 4,5X50 SCREW CF 4,5X50	5
G	SUPORTE FIXAÇÃO SOPORTE DE FIJACION FIXING SUPPORT	1
H	CAPA PROTEÇÃO PROTECCIÓN ANGLE BRACKET	1
I	BUCHA PLÁSTICA CASQUILLO BUSHING	1
J	TAMBOR MINIFIX TUERCA MINIFIX MINIFIX DRUM	4
K	PARAFUSO MINIFIX TORNILLO MINIFIX SCREW MINIFIX	4
M	PREGO 10X10 CLAVO 10X10 NAIL 10X10	50
N	ADESIVO TAPA FURO ADHESIVO STICKER	5
P2	PUXADOR 253mm TIRADOR PULLER	1
P3	PUXADOR 133mm TIRADOR PULLER	1
PE	PÉ FOOT	4
R	FIXADOR COSTA FIJADOR PARA FONDO BACK SUPPORT	3
U	PARAFUSO CC 4X16 TORNILLO CC 4X16 SCREW CC 4X16	12
V	COLA PEGAMENTO GLUE	1
Y	PARAFUSO CC 4X30 TORNILLO CC 4X30 SCREW CC 4X30	4
L	CANTONEIRA ESQUINERO CORNER	4



REF	DESC	COMP	LARG	ESP	QTD.
PA8402-01	LATERAL DIR/LADO DERECHO/RIGHT SIDE	1200	497	15	1
PA8402-02	LATERAL ESQ/LADO IZQUIERDO/LEFT SIDE	1200	497	15	1
PA8402-04	CHAPÉU/SOMBRERO/HAT	678	418	15	1
PA8402-05	PRATELEIRA/ESTANTE/SHELF	648	400	15	2
PA8402-06	TRAVESSA/TRAVESAÑO/PLATTER	648	130	15	1
PA8402-10	PORTA/PUERTA/DOOR	304	675	15	1
PA8402-20	COSTA/FONDO/BACK	647	325	3	1

LISTA DE FERRAGENS / LISTA DE ACCESORIOS / HARDWARE LIST			
COD	DESCRIÇÃO / DESCRIPCIÓN / DESCRIPTION		QTD
A	 CAVILHA Ø6X30 CLAVIA Ø6X30 WOOD DOWEL Ø6X30		14
B	 PARAFUSO CC 4X14 REBAXE TORNILLO CC 4X14 SCREW CC 4X14		10
C	 PARAFUSO CC 4X40 TORNILLO CC 4X40 SCREW CC 4X40		18
D	 PARAFUSO CC 4X30 TORNILLO CC 4X30 SCREW CC 4X30		02
DB	 DOB 35 SUP ALTA AMORT BISAGRA HINGE		02
F	 PARAFUSO CF 4,5X50 TORNILLO CF 4,5X50 SCREW CF 4,5X50		01
G	 SUPORTE FIXAÇÃO SOPORTE DE FIJACIÓN FIXING SUPPORT		01
H	 PROTEÇÃO SUP CANTONEIRA PROTECCIÓN ANGLE BRACKET		01
I	 BUCHA PLÁSTICA CASQUILLO BUSHING		01
M	 PREGO 10X10 CLAVO 10X10 NAIL		30
N	 ADESIVO TAPA FURO ADHESIVO STICKER		10
P1	 PUXADOR 533mm TIRADOR PULLER		01
V	 COLA PEGAMENTO GLUE		01
X	 PISTÃO PISTON PISTON		01
U	 PARAFUSO CC 4X16 TORNILLO CC 4X16 SCREW CC 4X16		12



"IMPORTANTE LER COM ATENÇÃO E GUARDAR PARA EVENTUAIS CONSULTAS".

1

PA 8502

Fixar as cavilhas c/ cola
 Fije los pivotes con cola
 Attach the dowels with glue

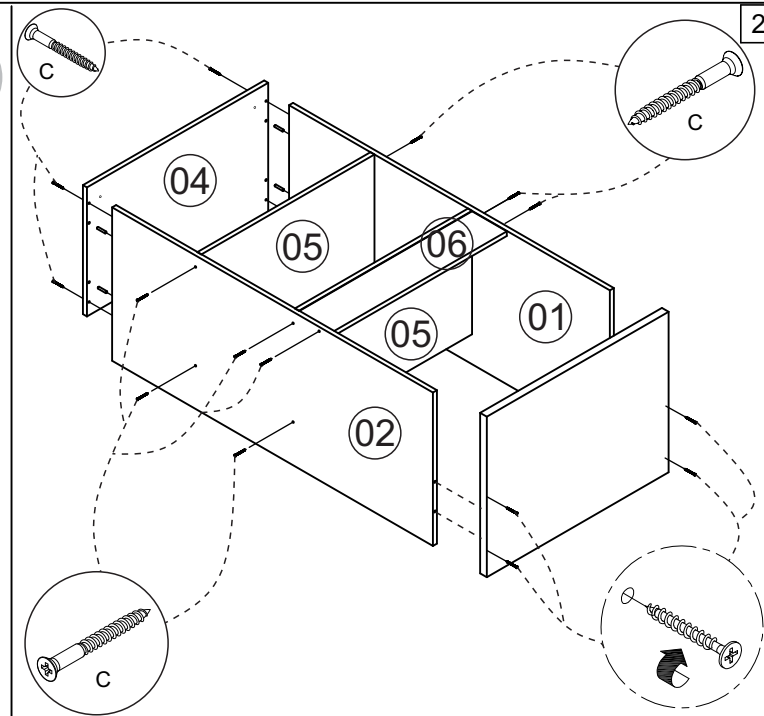
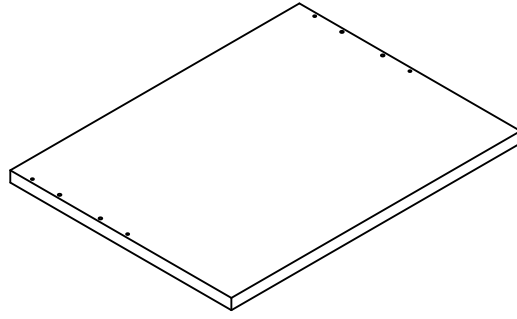

2

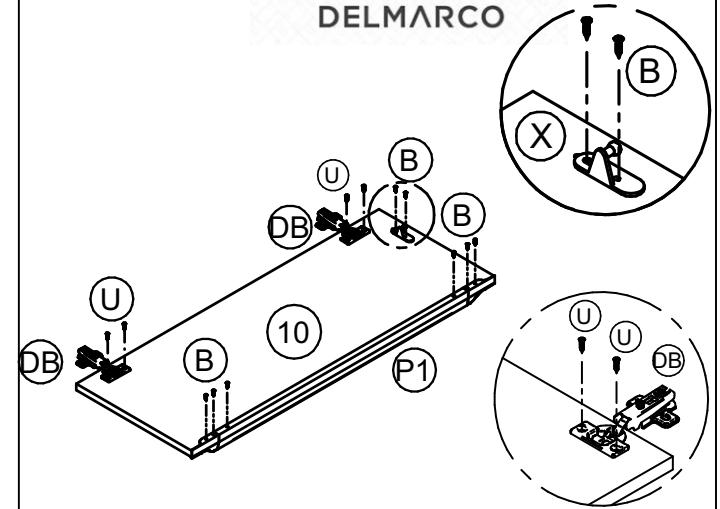

3

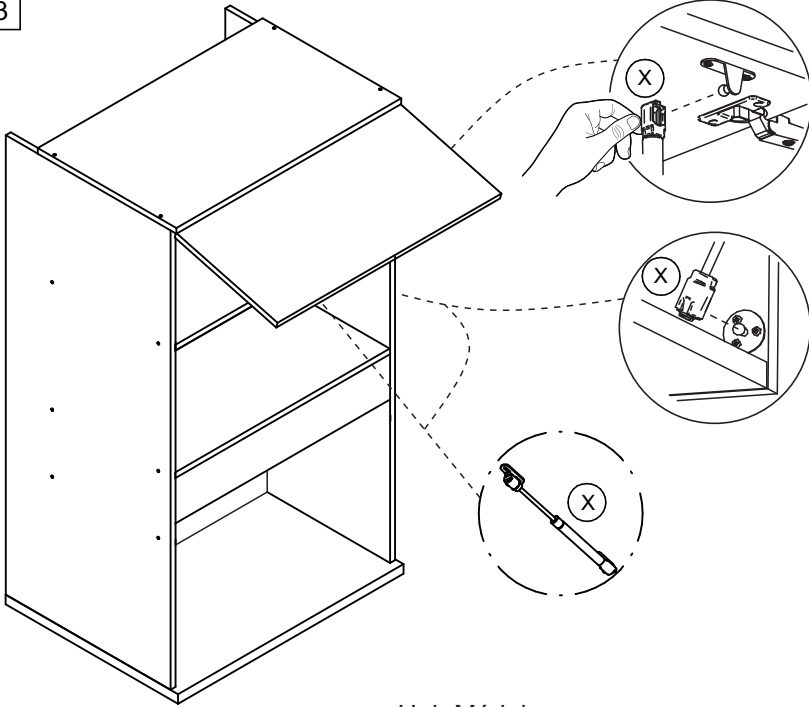

4

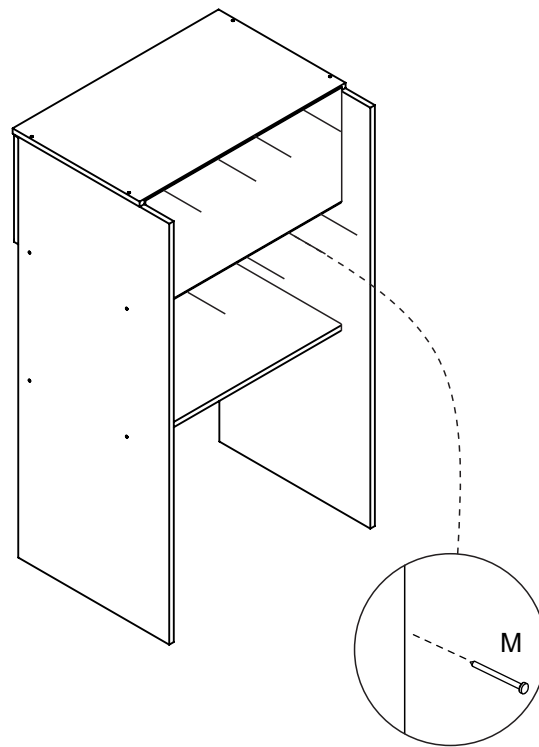

5

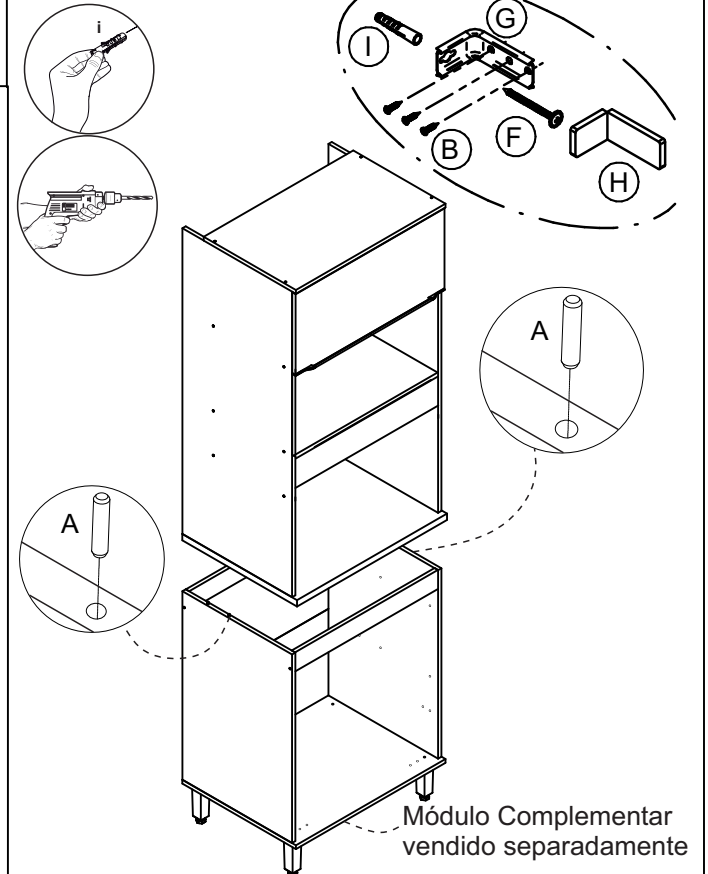

Unir Módulos con
 Parafusos «D»

Módulo Complementar
 vendido separadamente