

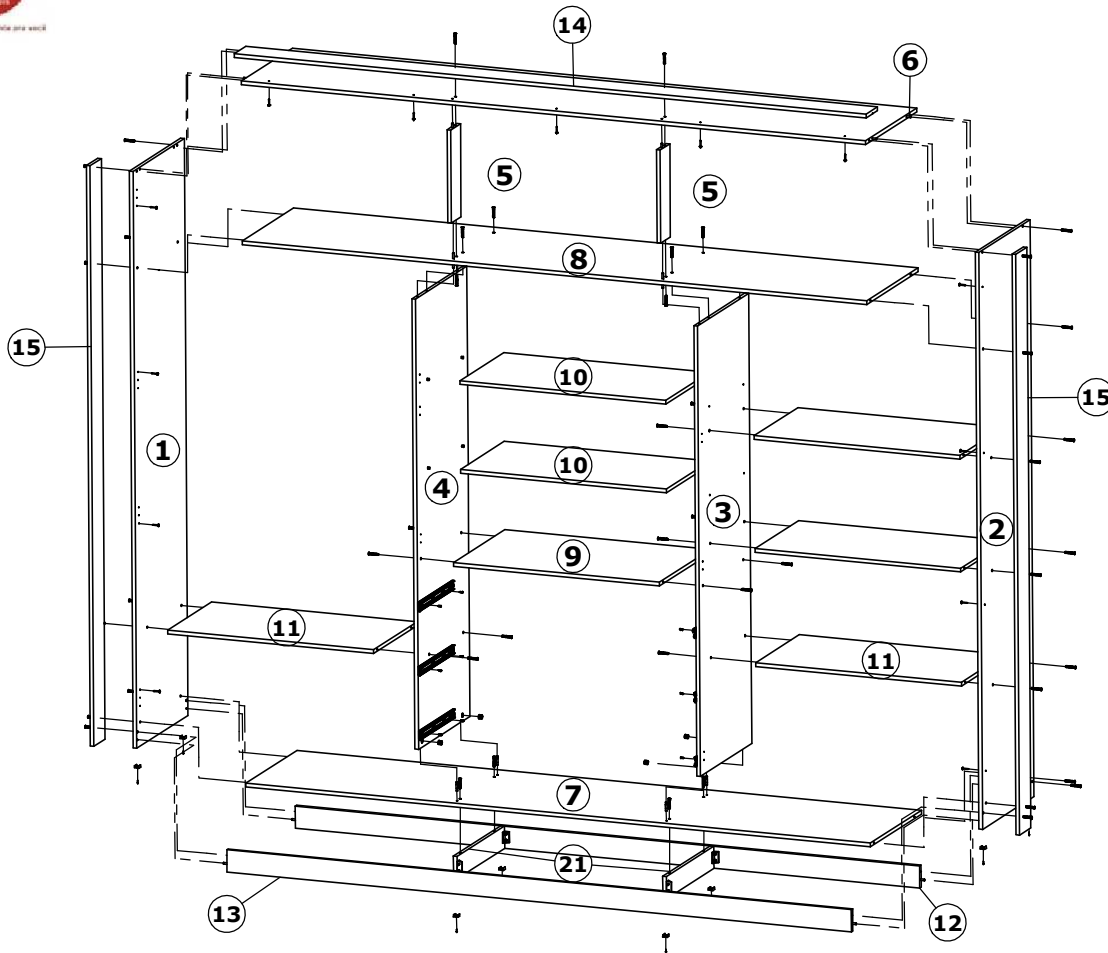

# Roupeiro Veneza 6 Portas / Wardrobe Veneza 6 Door / Armario Veneza 6 Puertas

Faithful+Gardner



## Montagem Gavetas

segunda-feira, 22 de maio de 2023

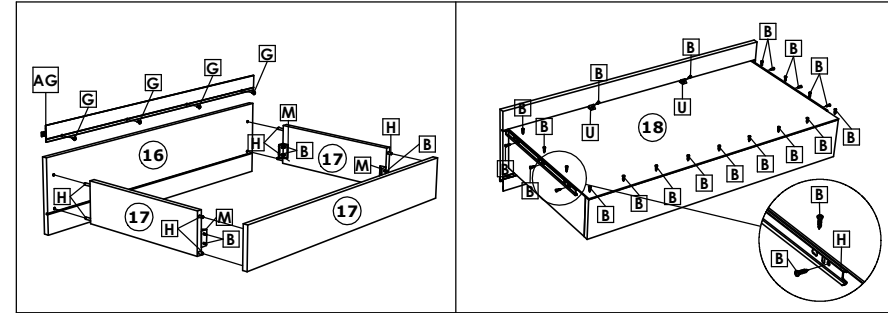

## Roupeiro 6P 3Gav Veneza

Peça / Piece	Cod. Almendra	Cod. Almendra Off White	Descrição	Description	Descripción	Qtde Qty	Compr Length	Larg. Width	Esp. Thickness
1	P18074	P18074	Lateral Esquerda	Left Panel	Lateral Izquierda	1	2288	528	15
2	P18073	P18073	Lateral Direita	Right Panel	Lateral Derecha	1	2288	528	15
3	P17955	P17955	Divisão Direita	Division Right	Division Derecha	1	1786	528	15
4	P17956	P17956	Divisão Esquerda	Division Left	División Izquierda	1	1786	528	15
5	P15705	P15705	Divisão Maleiro	Maleiro Division	División Maleiro	2	369	100	15
6	P17958	P17958	Tampo Sup	Surface Sup	Tapa Sup	1	2580	528	15
7	P17957	P17957	Tampo Inf.	Inf Top	Tapa Inf	1	2580	528	15
8	P17959	P17959	Tampo Int.	Int. Top	Tapa	1	2580	528	15
9	P17960	P17960	Tampo (um lado sem pintura)	Cover (One side unpainted)	Tapa (Un lado sin pintura)	1	850	528	15
10	P17962	P17962	Prateleira shelf	shelf	estante	2	850	450	15
11	P17961	P17961	Tampo Lateral	Side Table	Tapa Lateral	4	850	450	15
12	P17966	P17966	Traseiro Pé	Rear Foot	Trasero Pie	1	2580	88	15
13	P18077	P18077	Frente Pé	Front Foot	Frente Pie	1	2580	88	15
14	P18076	P18076	Moldura Sup	Sup. frame	Marco sup.	1	2610	116	15
15	P18075	P18075	Moldura Lateral	Side Frame	Marco lateral	2	2303	116	15
16	P17973	P19540	Frente Gaveta	Drawer Frontal	Frente del Cajón	3	861	220	15
17	P17974	P17974	Lateral Gaveta	Side Drawer	Lateral del Cajón	6	385	120	15
18	P17971	P17971	Fundo Gaveta	Background Drawer	Fondo del Cajón	3	825	406	2,5
19	P17975	P17975	Traseiro Gaveta	Rear Drawer	Traseo del Cajón	3	826	120	15
20	P17972	P17972	Fundo	Background	Fondo	3	2190	429	2,5
21	P17967	P17967	Divisão Pé	Foot division	División del pie	2	489,5	88	15
22	P17951	P19538	Porta Lateral	Side door	Puerta lateral	4	2190	429	15
23	P17952	P19539	Porta Central	Central Door	Puerta central	2	1425	429	15

Cod.	Qt.	Cod.	Qt.	Cod.	Qt.	Cod.	Qt.	Cod.	Qt.	Cod.	Qt.	Cod.	Qt.	Cod.	Qt.	Cod.	Qt.	Cod.	Qt.
A	4	B	133	C	4	D	48	E	124	F	8	G	12	H	34	I	13		
J	4	K	8	L	2	M	16	N	36	O	180	P	8	Q	2	R	4		
S	4	T	28	U	6	V	16	W	22	X	22	Y	2	Z	1	AA	3		
AB	8	AC	3	AD	2	AE	4	AF	2	AG	3	AH	1	AI	1				

## Roupeiro Veneza Glass

24	37737	37737	Espelho	Mirror	Espejo	2	1423	427	15
----	-------	-------	---------	--------	--------	---	------	-----	----



**Atenção com a cor do acabamento!  
Em caso de assistência solicitar o código de acordo com a cor da peça.**

## Medidas em mm



# Roupeiro Veneza 6 Portas / Wardrobe Veneza 6 Door / Armario Veneza 6 Puertas

## 1º Passo / Step / Paso

### Atenção / Attention / Atención

Inicie a Montagem , fixando Frente (13), Traseiro (12) e Divisão Pé (21), Utilizando Cantoneira (M) e Parafusos (B).

Em seguida faça a fixação do Tampo inferior (7) com Parafusos (D) e (A)/

Begin Assembly by securing Front (13), Rear (12), and Foot Division (21), Using Angle (M) and Screws (B).

Then fasten Bottom Top (7) with Screws (D) and (A)/

Comience el ensamblaje uniendo la parte delantera (13), la parte trasera (12) y la división de pie (21), utilizando el ángulo (M) y los tornillos (B).

Luego fije la parte inferior inferior (7) con los tornillos (D) y (A).

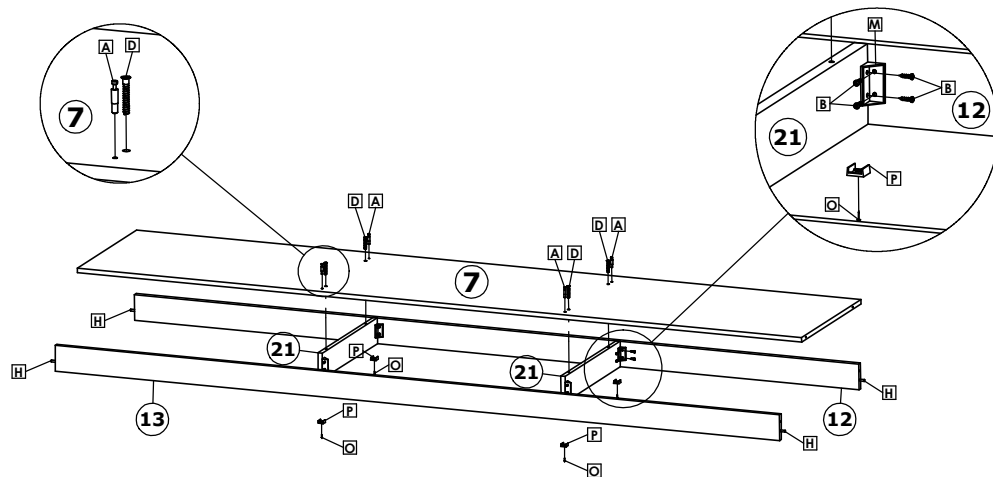

## 2º Passo / Step / Paso

Após a montagem da Base do Roupeiro, posicione as Divisões (3) e (4) sobre o Tampo (7) e fixe com Parafusos (A) e Tambor (R).

Em seguida fixe os tamos (9) e (11) com Parafusos (D)/

After mounting the Wardrobe Base, position Divisions (3) y (4) on Top (7) and secure with Screws (A) and Drum (R).

Then fasten tops (9) and (11) with Screws (D)/

Después de montar la base del armario, coloque las divisiones (3) and (4) en la parte superior (7) y fíjelas con los tornillos (A) y el tambor (R).

En seguida asegure las tapas (9) y (11) con tornillos (D).

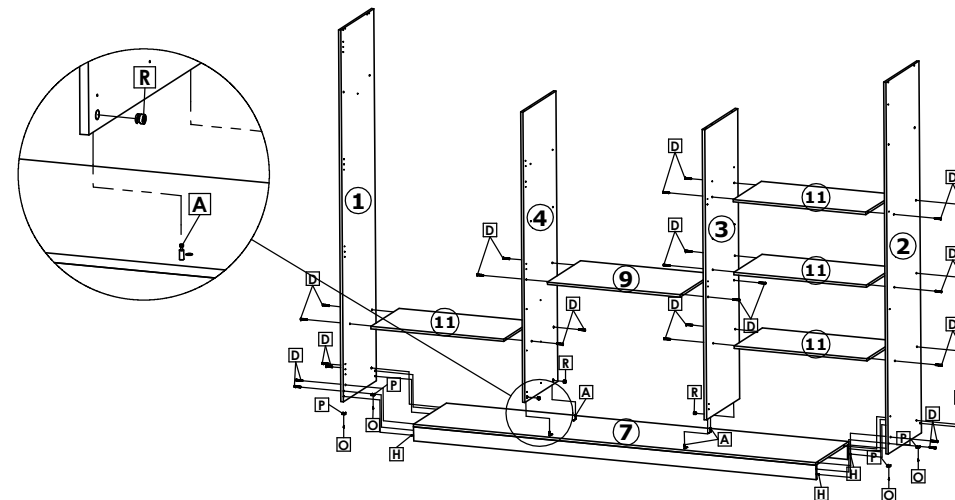

## 3º Passo / Step / Paso

Faça a montagem externa do Tampo (8) com a Divisão Maleiro (5), fixandos com Parafuso (D) e Cavilha (L).

Logo fixar conjunto sobre as Divisões (3) e (4), entre as Laterais (1) e (2) com Parafusos (D)/

Make the external assembly of the Top (8) with the Maleiro Division (5), fixing with Screw (D) and Bolt (L).

Then fix the set on the Divisions (3) y (4) and between Sides (1) and (2) with Screws (D)/

Realice el montaje externo del Top (8) con el Maleiro Division (5), fijando con Tornillo (D) y Tornillo (L).

Luego arregla el set en el Divisiones (3) y (4), entre las caras (1) y (2) con tornillos (D).

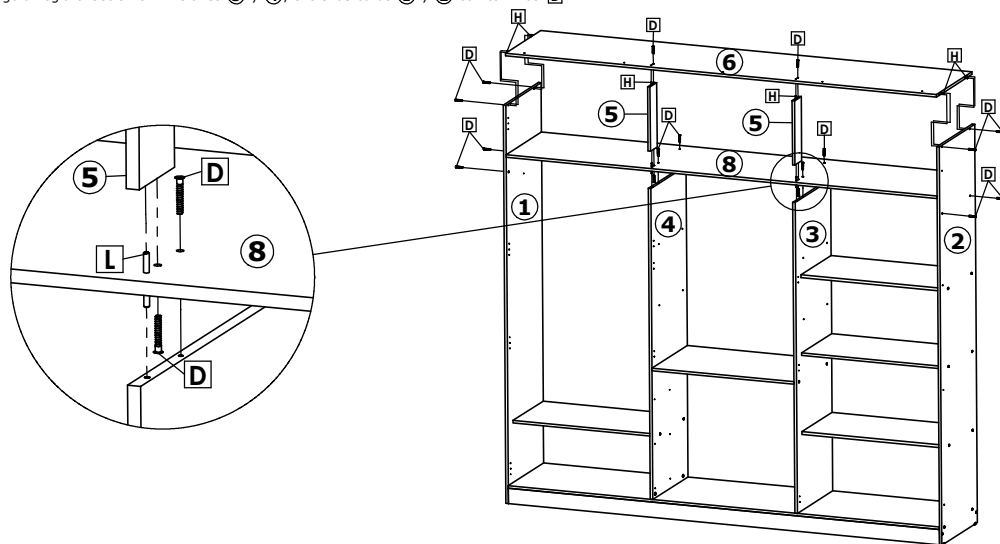

## 4º Passo / Step / Paso

Inicie a montagem fixando os fundos centrais (20), utilize pregos (Q) e Perfil H (AC). Em seguida fixe os

fundos laterais (20) com Pregos (Q), Presilhas (N), Perfil H (AC) e Presilha (NI)/

Start the assembly by fixing the central bases (20), use nails (Q) and Profile H (AC).

Then fix the side bottoms (20) with Nails (Q), Clips (N), Profile H (AC) and Cleat (NI)/

Inicie el montaje fijando las bases centrales (20), utilice clavos (Q) y Perfil H (AC).

Luego fije los fondos laterales (20) con clavos (Q), clips (N), perfil H (AC) y listón (NI).

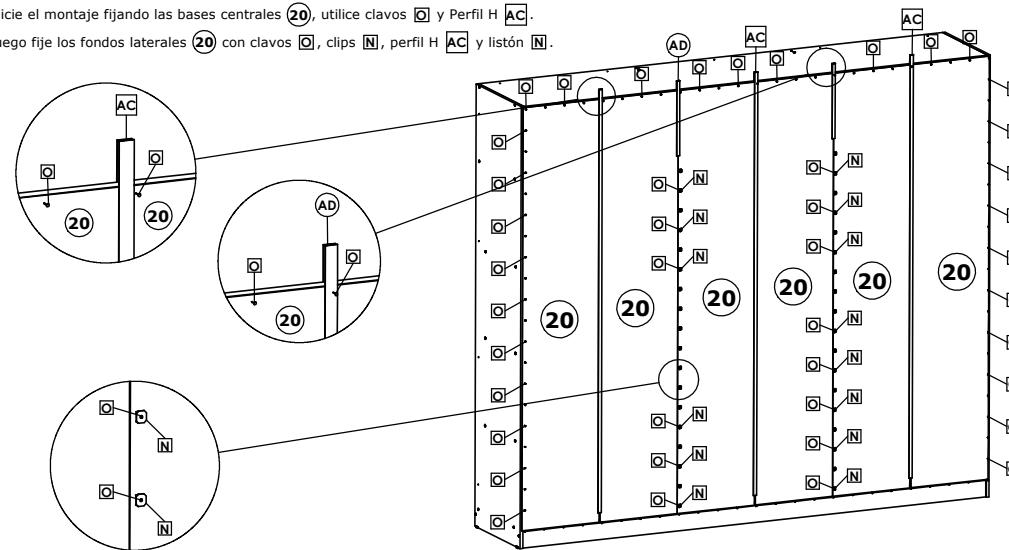

# Roupeiro Veneza 6 Portas / Wardrobe Veneza 6 Door / Armario Veneza 6 Puertas

## 5º Passo / Step / Paso

Fixar a moldura central (14) com parafusos (I). Fique atento ao rasgo da moldura pois é nele que os parafusos devem ser fixados.  
Em seguida fixar as molduras laterais (15), seguindo as mesmas orientações da moldura central (14)/

Fix the central frame (14) with screws (I), pay attention to the frame tear as it is where the screws must be fixed.  
Then fix the side frames (15), following the tables but the orientations of the central frame (14).

Fije el marco central (14) con los tornillos (I), preste atención al desgarramiento del marco ya que es donde deben fijarse los tornillos.  
En seguida fijar los marcos laterales (15), siguiendo las tablas pero las orientaciones del marco central (14).

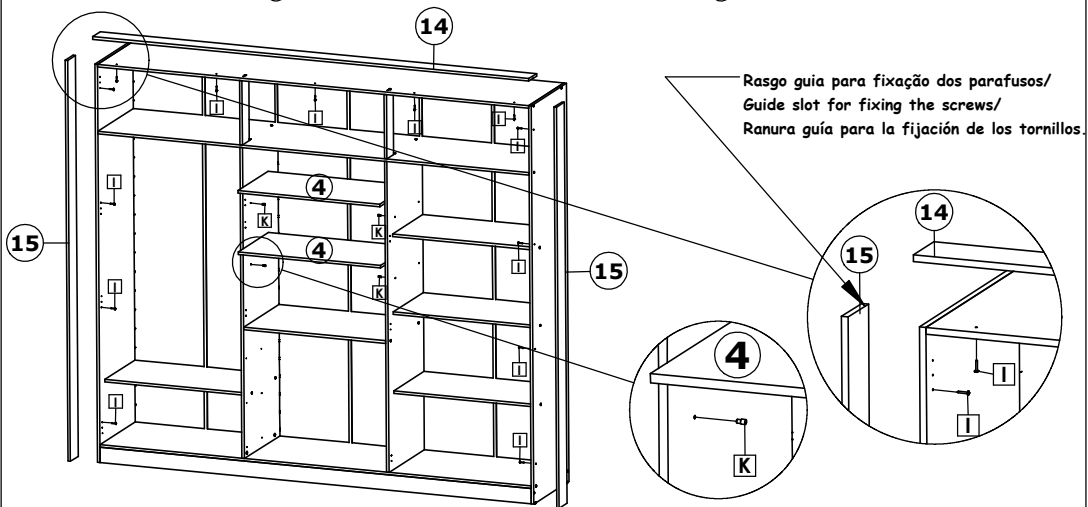

Rasgo guia para fixação dos parafusos/  
Guide slot for fixing the screws/  
Ranura guía para la fijación de los tornillos.

## 6º Passo / Step / Paso

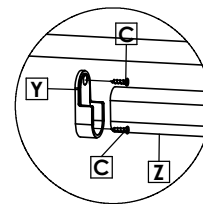

Utilizar gabarito de cabideiro (AI) para fazer a marcação, após fixar suporte (Y) com parafuso (C) /

Use clothes rack template (AI) to make the marking, after fixing support (Y) with screw (C) /

Utilice la plantilla de perchero (AI) para hacer la marca, después de fijar el soporte (Y) con el tornillo (C).

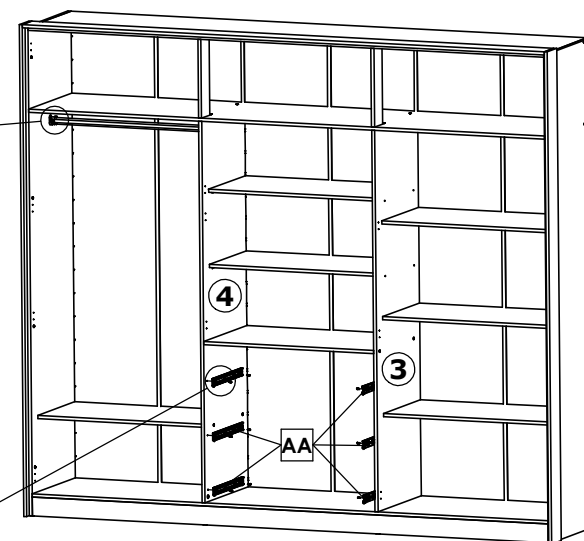
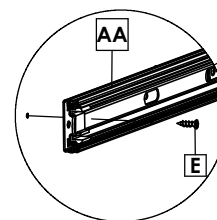

Fixar correções (AA) com parafusos (E), nas Divisões (3) e (4) /

Fix slides (AA) with screws (E), in Divisions (3) and (4) /

Fije las guías (AA) con los tornillos (E), en las Divisiones (3) y (4).

## Peso Suportado / Weight supported / peso que soporta

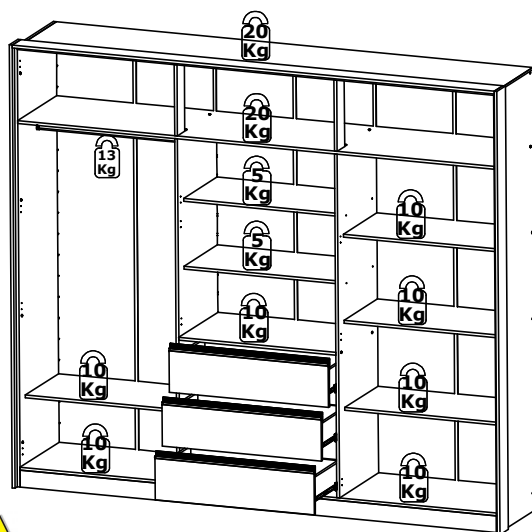

Peso suportado por cada Gaveta: 5 Kg  
Weight supported by each Drawer: 5 Kg  
Peso suportado por cada Cajón: 5 Kg

## Montagem Portas Veneza / Assembly Door Veneza / Montaje de la puerta de Veneza

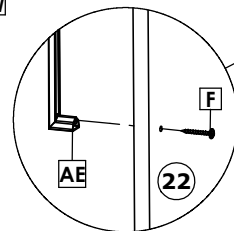
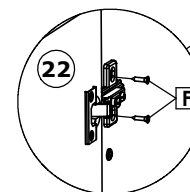
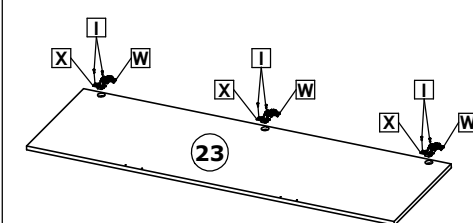
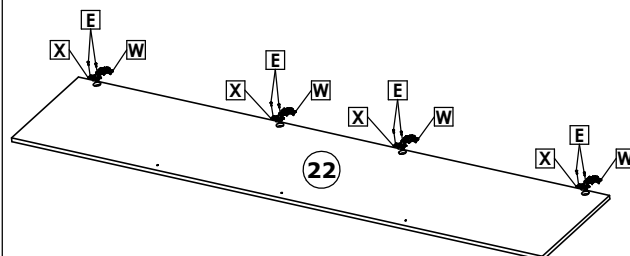

Fixar os puxadores (AE) nas portas (22) com parafusos (F) /  
Fix the handles (AE) to the doors (22) with screws (F) /  
Fije las manijas (AE) a las puertas (22) con tornillos (F).

# Roupeiro Veneza 6 Portas / Wardrobe Veneza 6 Door / Armario Veneza 6 Puertas

## Montagem Portas Royale New/ Royale New Doors/ Puertas Royale New

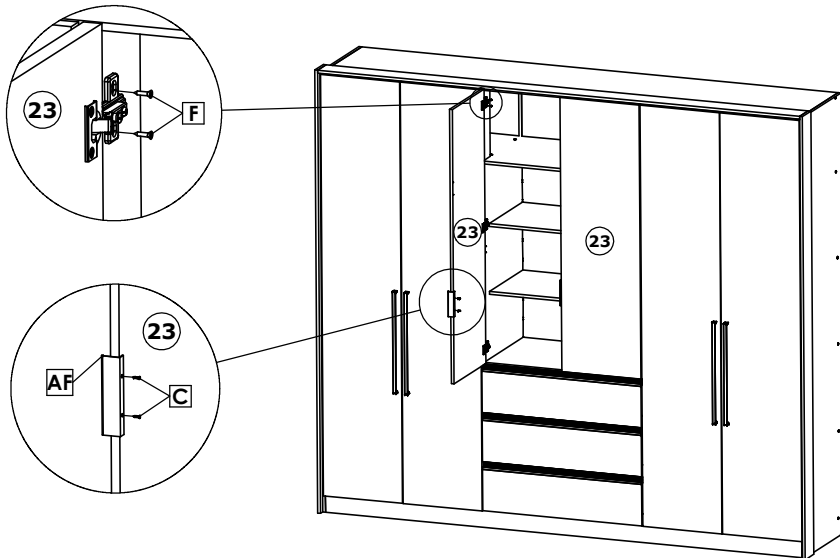

Fixar os puxadores **AF** nas portas **23** com parafusos **C** /  
 Fix the handles **AF** to the doors **23** with screws **C** /  
 Fije las manijas **AF** a las puertas **23** con tornillos **C**.

## Montagem dos Espelhos/ Mounting the Mirrors/ Montaje de los espejos

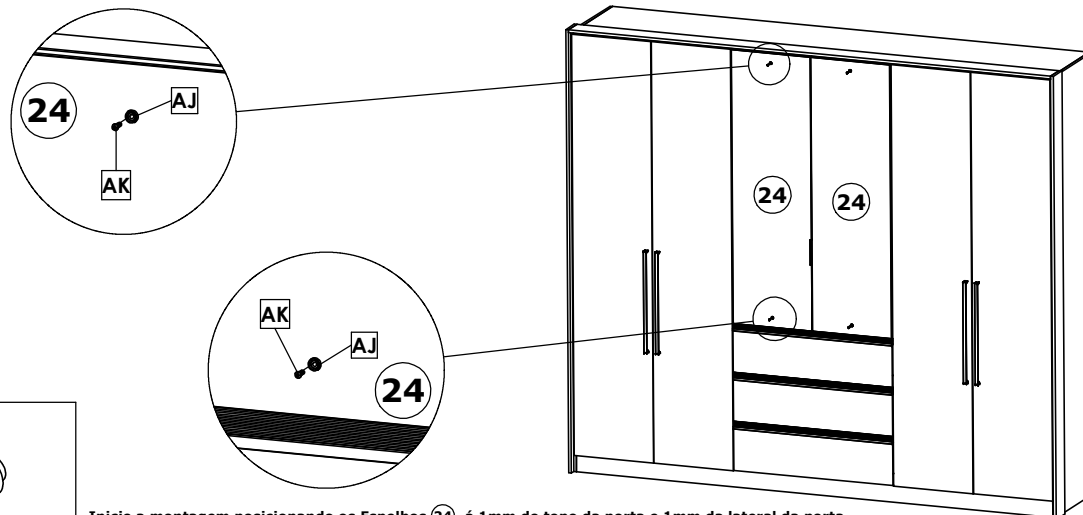

AJ	4
Suporte Vidro Pino 25676	
AK	4
Parafuso 3,5x14 CP 34125 - Zincado Branco	

Inicie a montagem posicionando os Espelhos **24**, á 1mm do topo da porta e 1mm da lateral da porta.  
 Logo fixe os Espelhos **24**, com Parafusos **AK** e Suporte Vidro Pino **AJ** /

Start the assembly by placing Mirrors **24**, 1mm from the top of the door and 1mm from the side of the door.  
 Then fix the Mirrors **24**, with Screws **AK** and Glass Support Pin **AJ** /

Inicie el montaje colocando los espejos a **24**, 1 mm de la parte superior de la puerta y 1mm del lateral de la puerta.  
 Luego fije los espejos **24**, con los tornillos **AK** y el pasador de soporte del vidrio **AJ**.

## Produto Montado/ Assembled Product/ Producto ensamblado

### Veneza

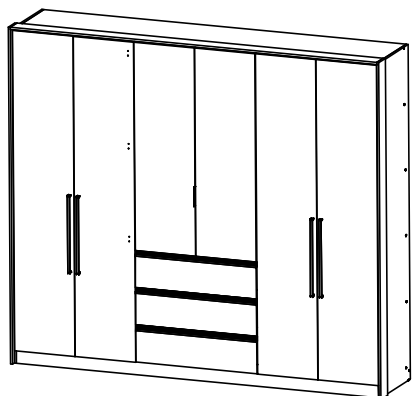

### Veneza Glass

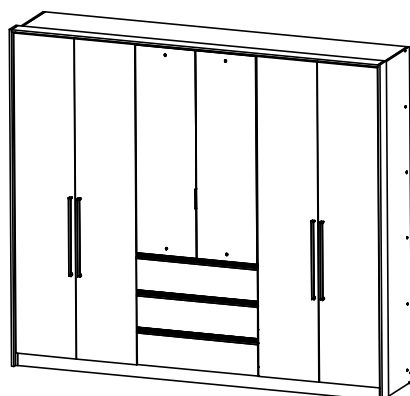

## Montagem Pés Veneza/ Mounting Feet Veneza/ Montaje Pies Veneza.

**!** Os Pés são opcionais /  
 Feet are optional /  
 Los Pies son opcionales.

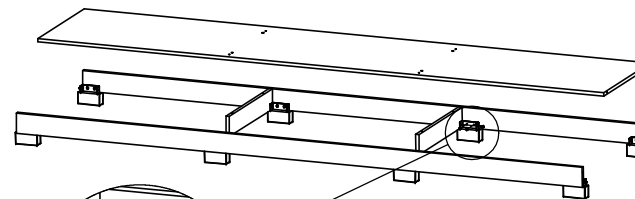

Na opção com Pés, fixar pés **AM** com Parafusos **AL** /  
 In the option with Feet, fix feet **AM** with Screws **AL** /  
 Na opção com Pés, fixar pés **AM** com Parafusos **AL**.

AL	24	AM	8
Parafuso 4,0x12 CF 38497		Pé Retangular 38436	