

Roupeiro / Ropero / Wardrobe

SORENTO/LUGANO

BC-7111 BC-2082

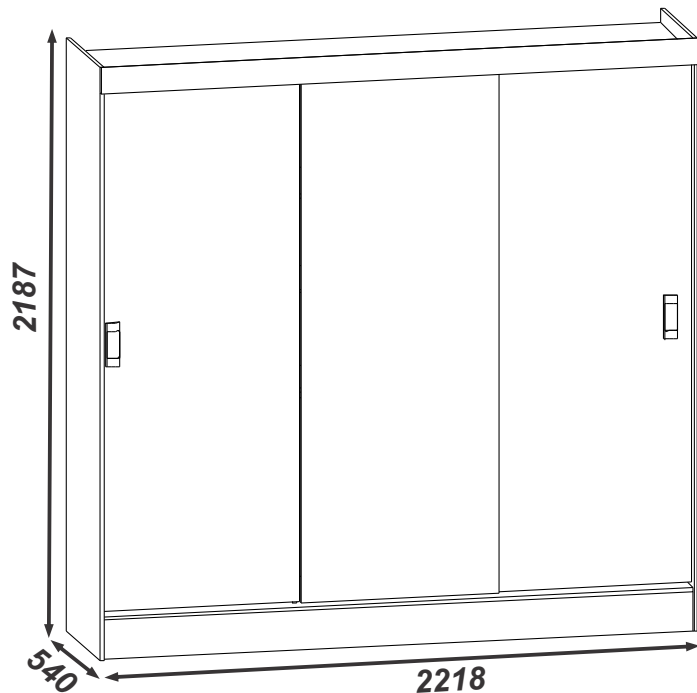

Instruções para a montagem do produto:

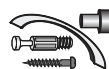

Separe as peças e acessórios de maneira organizada.

Separate the parts and accessories in an organized way.

Separate las piezas y accesorios de forma organizada

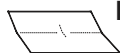

Forrar o chão com o papelão das embalagens.

Cover the floor with the cardboard from the pack.

Cubre el suelo con el cartón de los bultos.



É necessário duas pessoas para montar o produto.

It's necessary two people to assembly the product.

Se requiere dos personas para montar el producto.

Ferramentas necessárias (não fornecidas)

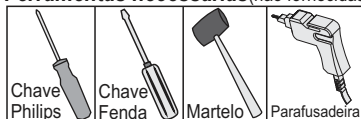

Chave
Philips

Chave
Fenda

Martelo

Parafusadeira

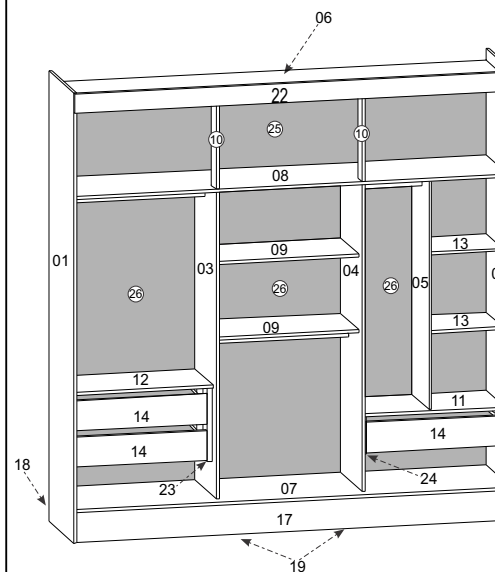
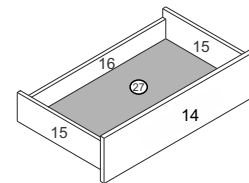
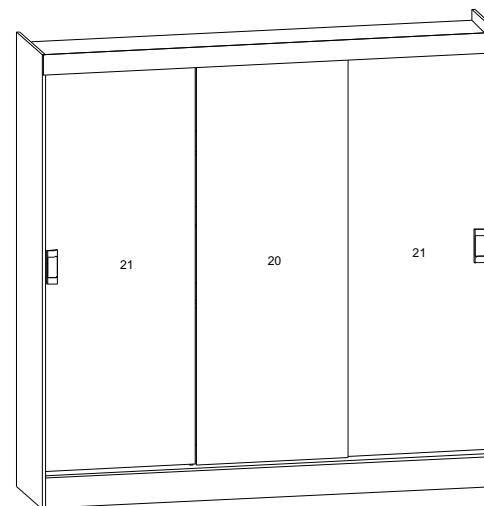

Por

- 01- Lateral esquerda
- 02- Lateral direita
- 03- Divisão esquerda
- 04- Divisão direita
- 05- Divisão direita menor
- 06- Tampo superior
- 07- Tampo inferior
- 08- Tampo maleiro
- 09- Prateleira (2X)
- 10- Pilastra (2X)
- 11- Tampo gaveteiro direito
- 12- Tampo gaveteiro esquerdo
- 13- Prateleiras direita (2X)
- 14- Frente de gaveta (3X)
- 15- Lateral de gaveta (6X)
- 16- Traseiro de gaveta (3X)
- 17- Rodapé Frontal
- 18- Rodapé Traseiro
- 19- Travessa Rodapé (2x)
- 20- Porta central
- 21- Porta Lateral (2X)
- 22- Frontal Superior
- 23- Distanciador maior (2X)
- 24- Distanciador Menor (2X)
- 25- Costa Maleiro
- 26- Costa
- 27- Fundo de Gaveta (3x)

Esp

- 01- Left Side
- 02- Right Side
- 03- Left Division
- 04- Right Division
- 05- Right Little Division
- 06- Upper Top
- 07- Lower Top
- 08- Luggage Locker Top
- 09- Shelf (2X)
- 10- Pilaster (2X)
- 11- Right Drawer Top
- 12- Left Drawer Top
- 13- Right Shelf (2X)
- 14- Drawer Front (3X)
- 15- Drawer Side (6X)
- 16- Drawer Back (3X)
- 17- Front Base Board
- 18- Back Base Board
- 19- Base Board Crossbar (2x)
- 20- Central Door
- 21- Side Door (2X)
- 22- Front
- 23- Bigger Spacer (2X)
- 24- Little Spacer (2X)
- 25- Luggage Locker Back Panel
- 26- Back Panel
- 27- Drawer Bottom (3x)

Eng

- 01- Lateral Izquierda
- 02- Lateral Derecha
- 03- División Izquierda
- 04- División Derecha
- 05- División Derecha Menor
- 06- Tapa Superior
- 07- Tapa inferior
- 08- Tapa armario de equipaje
- 09- Estante (2x)
- 10- Pilastra (2x)
- 11- Tapa del cajón derecho
- 12- Tapa del cajón izquierdo
- 13- Estante Derecha (2x)
- 14- Frente del Cajón (3X)
- 15- Lateral del Cajón (6X)
- 16- Traseiro del Cajón (3X)
- 17- Zócalo Frontal
- 18- Zócalo Trasero
- 19- Travessaño del Zócalo (2x)
- 20- Puerta central
- 21- Puerta Lateral (2X)
- 22- Frontal Superior
- 23- Espaciador Mayor (2X)
- 24- Espaciador Menor (2X)
- 25- Dorso Armario de Quipaje
- 26- Dorso
- 27- Fondo del Cajón (3x)

DIMENSÕES PEÇAS PRONTAS

- 01-2187 X 525 X 15 MM
- 02-2187 X 525 X 15 MM
- 03-1554 X 449 X 15 MM
- 04-1554 X 449 X 15 MM
- 05-1200 X 385 X 15 MM
- 06-2187 X 524 X 15 MM
- 07-2187 X 524 X 15 MM
- 08-2187 X 450 X 15 MM
- 09-719 X 386 X 15 MM
- 10-386 X 95 X 15 MM
- 11-719 X 386 X 15 MM
- 12-719 X 386 X 15 MM
- 13-360 X 360 X 15 MM
- 14-688 X 147 X 15 MM
- 15-338 X 95 X 15 MM
- 16-640 X 65 X 15 MM
- 17-2187 X 147 X 15 MM
- 18-2187 X 147 X 15 MM
- 19-465 X 147 X 15 MM
- 20-1925 X 739 X 15 MM
- 21-1925 X 739 X 15 MM
- 22-2218 X 94 X 15 MM
- 23-359 X 94 X 25 MM
- 24-177 X 94 X 25 MM
- 25-2202 X 404 X 3 MM
- 26-1574 X 734 X 3 MM
- 27-668 X 341 X 3 MM

DIMENSIONES DE LAS PEZAS PRONTAS

- 01-2187 X 525 X 15 MM
- 02-2187 X 525 X 15 MM
- 03-1554 X 449 X 15 MM
- 04-1554 X 449 X 15 MM
- 05-1200 X 385 X 15 MM
- 06-2187 X 524 X 15 MM
- 07-2187 X 524 X 15 MM
- 08-2187 X 450 X 15 MM
- 09-719 X 386 X 15 MM
- 10-386 X 95 X 15 MM
- 11-719 X 386 X 15 MM
- 12-719 X 386 X 15 MM
- 13-360 X 360 X 15 MM
- 14-688 X 147 X 15 MM
- 15-338 X 95 X 15 MM
- 16-640 X 65 X 15 MM
- 17-2187 X 147 X 15 MM
- 18-2187 X 147 X 15 MM
- 19-465 X 147 X 15 MM
- 20-1925 X 739 X 15 MM
- 21-1925 X 739 X 15 MM
- 22-2218 X 94 X 15 MM
- 23-359 X 94 X 25 MM
- 24-177 X 94 X 25 MM
- 25-2202 X 404 X 3 MM
- 26-1574 X 734 X 3 MM
- 27-668 X 341 X 3 MM

DIMENSIONS READY MODE PARTS

- 01-2187 X 525 X 15 MM
- 02-2187 X 525 X 15 MM
- 03-1554 X 449 X 15 MM
- 04-1554 X 449 X 15 MM
- 05-1200 X 385 X 15 MM
- 06-2187 X 524 X 15 MM
- 07-2187 X 524 X 15 MM
- 08-2187 X 450 X 15 MM
- 09-719 X 386 X 15 MM
- 10-386 X 95 X 15 MM
- 11-719 X 386 X 15 MM
- 12-719 X 386 X 15 MM
- 13-360 X 360 X 15 MM
- 14-688 X 147 X 15 MM
- 15-338 X 95 X 15 MM
- 16-640 X 65 X 15 MM
- 17-2187 X 147 X 15 MM
- 18-2187 X 147 X 15 MM
- 19-465 X 147 X 15 MM
- 20-1925 X 739 X 15 MM
- 21-1925 X 739 X 15 MM
- 22-2218 X 94 X 15 MM
- 23-359 X 94 X 25 MM
- 24-177 X 94 X 25 MM
- 25-2202 X 404 X 3 MM
- 26-1574 X 734 X 3 MM
- 27-668 X 341 X 3 MM

Ferragens/Herraje/Hardware:

Cód	Itens	Quan
330	A Cavilhas 6 x 30 Clavija Bowel	68
0289	B Parafuso 3,5 x 40 c/c Tornillo Screw	34
0115	C Parafuso Minifix Tornillo Screw	18
0350	D Tambor girofix 15 mm Minifix Minifix	18
0744	E Taxa 13 x 15 Clavo 13 x 15 Nail 13 x 15	12
0296	F Taxa 10 x 10 Clavo 10 x 10 Nail 10 x 10	140
0290	G Parafuso 3,5 x 14c/c Tornillo Screw	122
2283	H Parafuso 4,0 x 30 c/c Tornillo Screw	06
0438	I Cantoneira Esquinera Cantoneira	30
0477	J Cola Pegamento Glue	01
0293	K Parafuso 3,5 x 14 c/ flangeado Tornillo Screw	04
3120	L Puxador danubio 128MM Tirador Handle	02
0308	M Sapata U 15 mm Pata Feet	08
0279	N Fixador de costa Fixador de espalda Fix back	30
3234	O Tubo Cabide oblongo 711 mm canelado Perchero Holding	02
3232	P Tubo Cabide oblongo 334 mm canelado Perchero Holding	01
0160	Q Corrediça 350 mm Cinza Rieles Slides	03
5159	R Cavilhas 6 x 50 Clavija Bowel	02
3153	S Batente de Silicone 8mm Tope de Silicona Silicone Stop	12
3247	T Trilho guia inferior aluminio 2184mm Riel inferior aluminio aluminum lower guide rail	01
3246	U Trilho guia E plástico 2184mm Riel plastico E Plastic guide rail E	01
3250	V Testeira de aluminio 1925	06
2296	X Suporte cabideiro oblongo canelado Soporte percha Hanger holding	06
5114	Z Kit 3 portas de correr c/ parafusos Kit 3 puertas corrediza c/tornillo Sliding door kit	03
----	Tapa Furo Adesivo 18mm COR 1 Pegatina Para Agujeros 18mm COLOR 1 Slap hole adesivo 18mm color 1	06

Montagem da gaveta Armado de los cajones Drawer Assembly

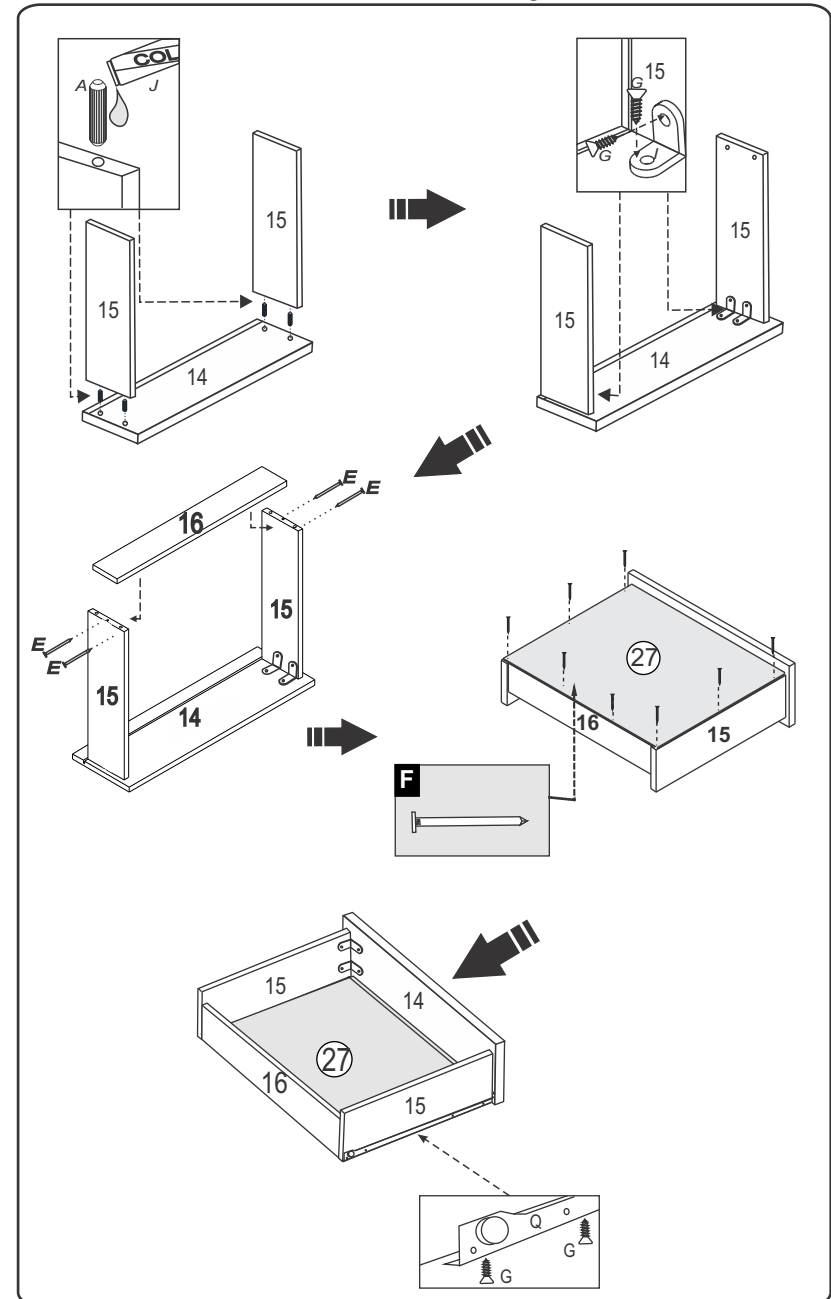

1º Passo
1º Paso
1º Step

*Atenção! ao parafusar a corredeira,
 ,cuidar o lado certo.*

*Atención! al atornillar la corredera,
 cuidar para que esté en el lado correcto*

*Attention!When screwing the slide,
 take care to do the right side*

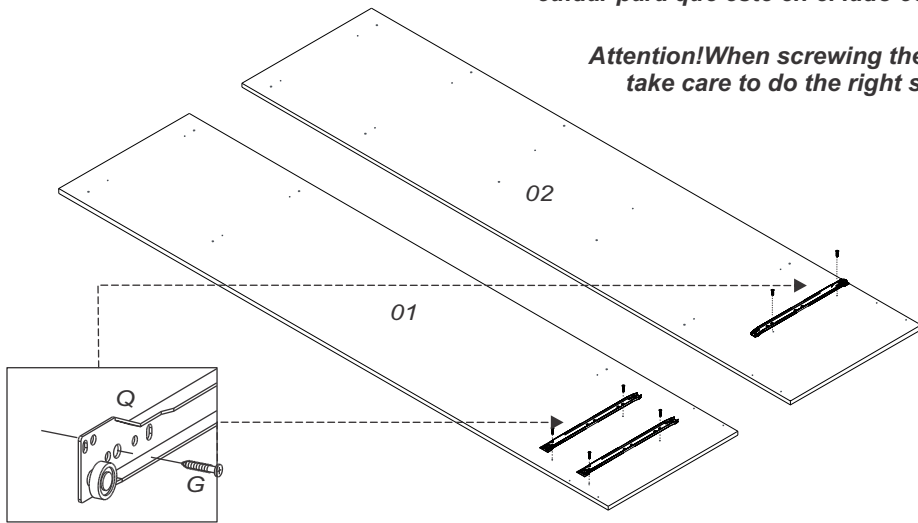

2º Passo
2º Paso
2º Step

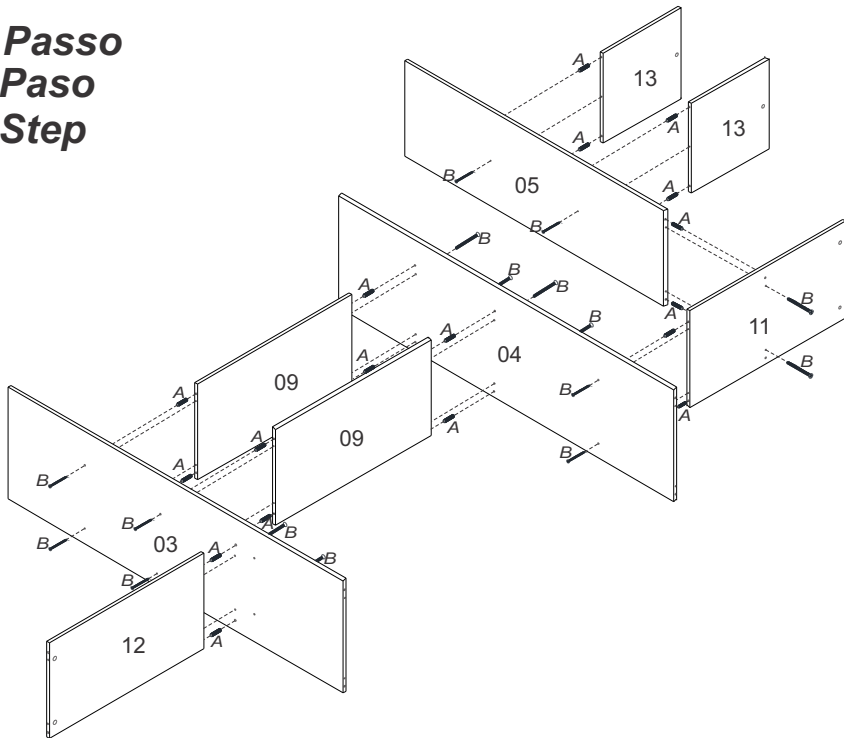

3º Passo
3º Paso
3º Step

Atenção!
 Cavilha (R) diferente
 para junção das peças
 Clavija diferente
 para juntar las piezas

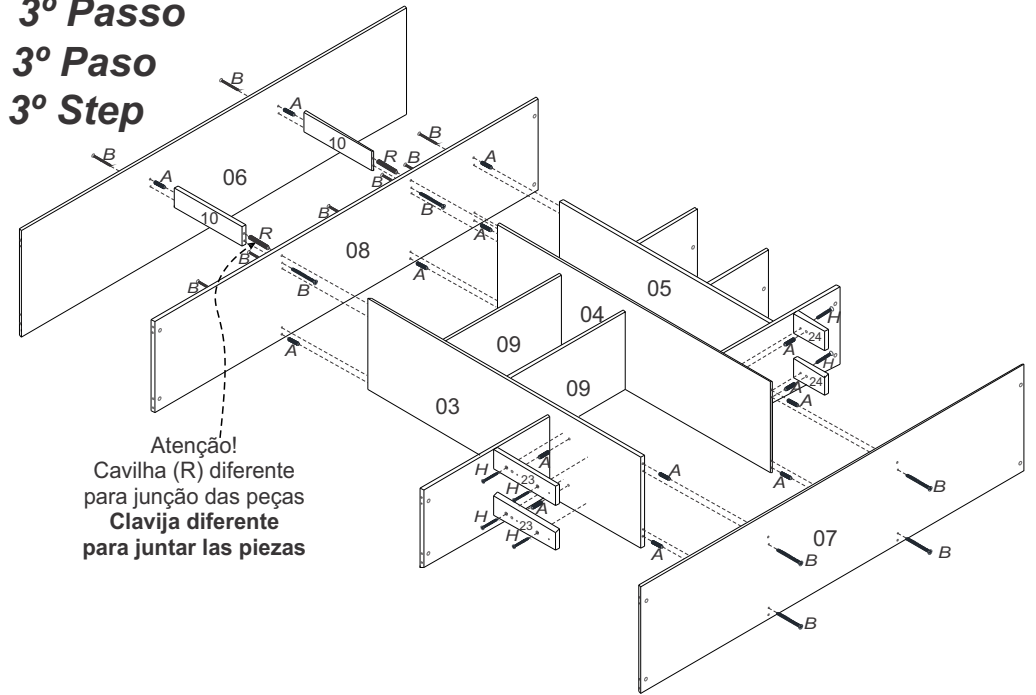

4º Passo
4º Paso
4º Step

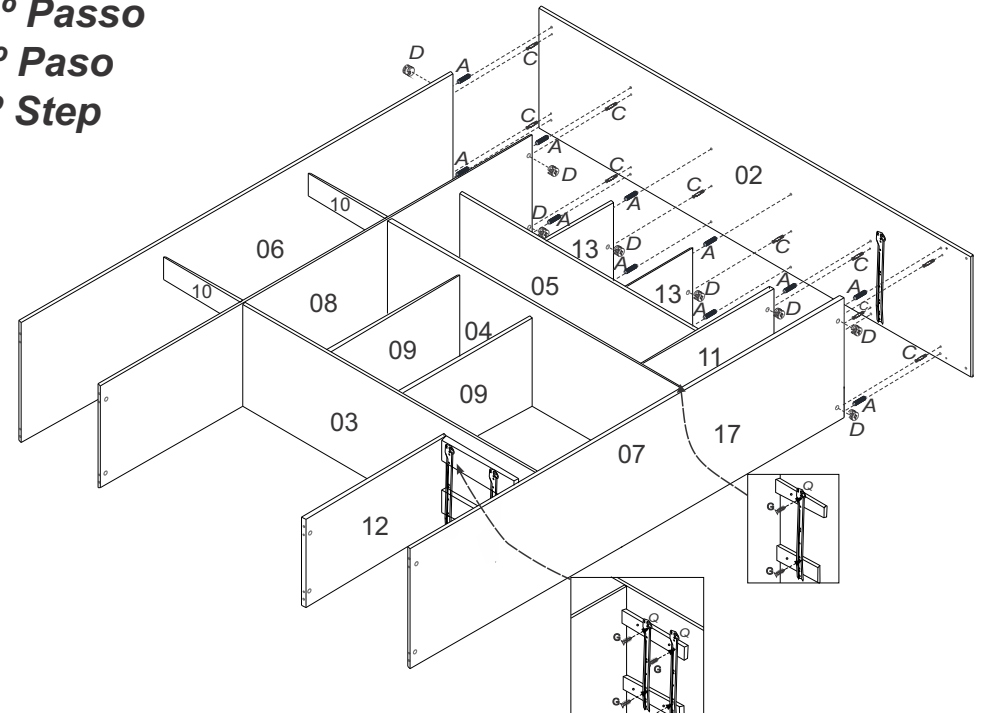

5º Passo

5º Paso

5º Step

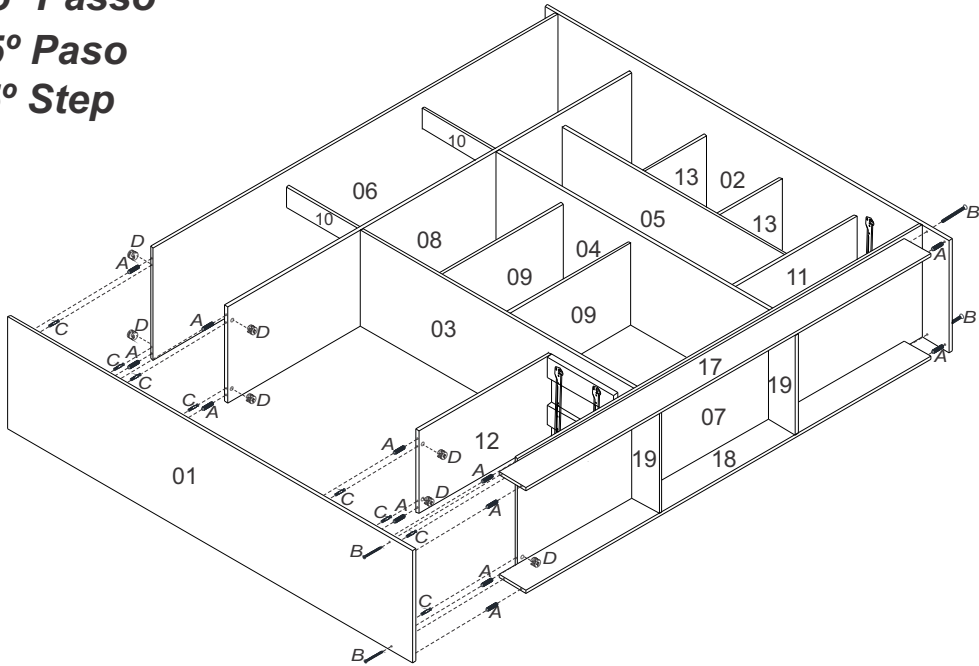

6º Passo

6º Paso

6º Step

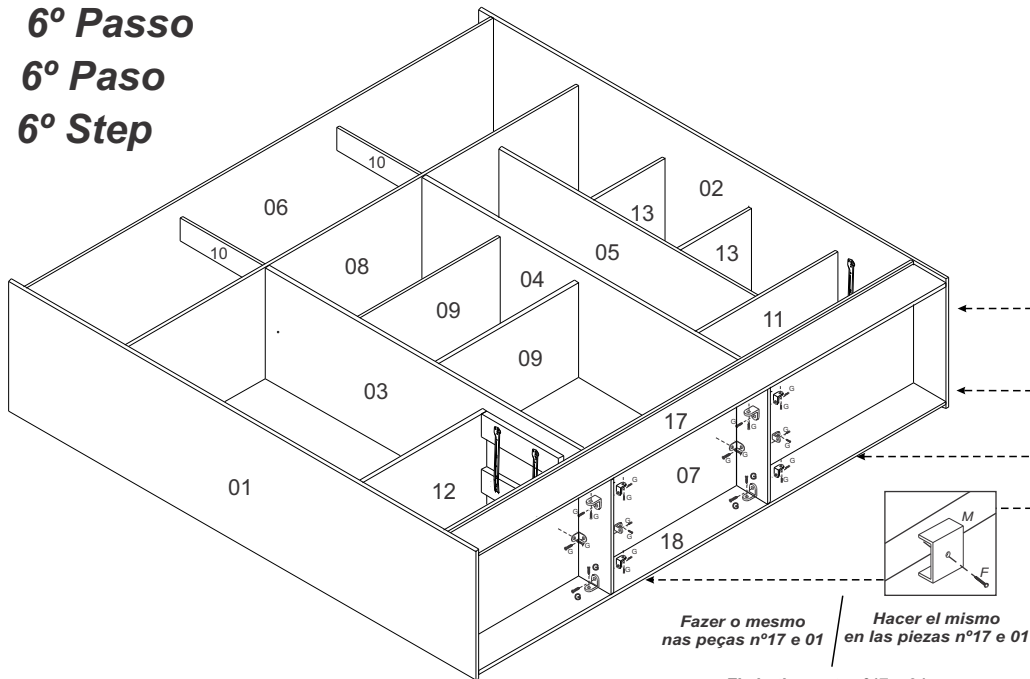

7º Passo

7º Paso

7º Step

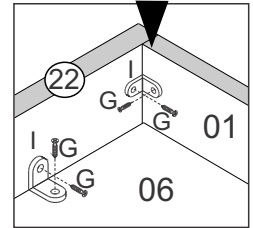
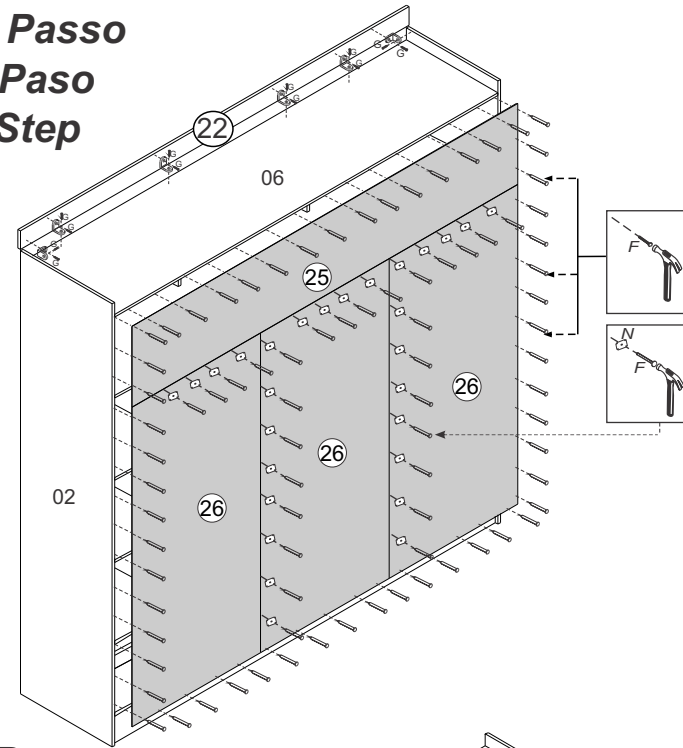

**Alinhar Frontal (22)
com a Lateral (01).**
**Alinear el Frontal (22)
con la Lateral (01).**
**Align the front (22)
With the side (01).**

8º Passo

8º Paso

8º Step

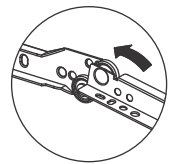
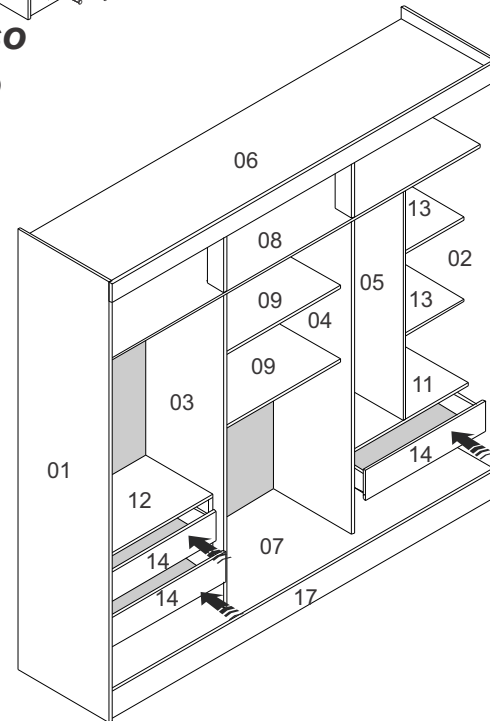

9º Passo

9º Paso

9º Step

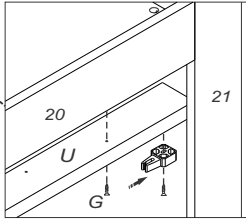
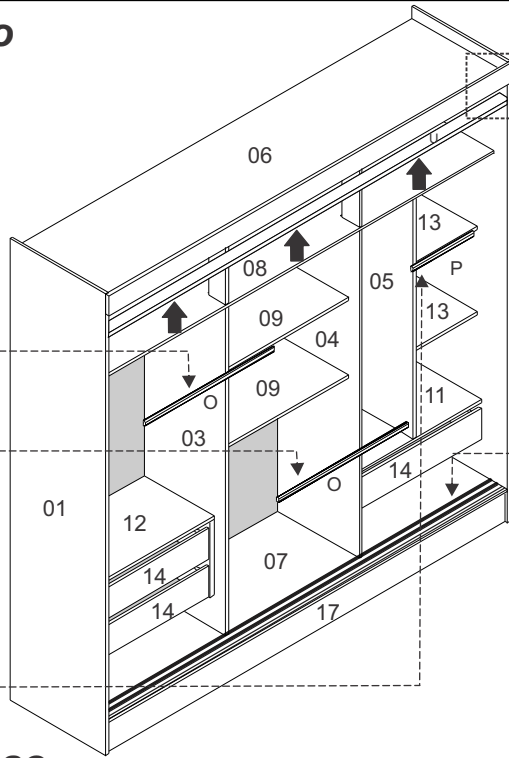
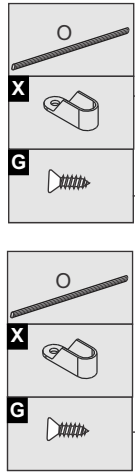

O freio da porta deve ser fixado no final do trilho, encostado na lateral.

The door brake, must be fixed in the end of the rail leaning in the side.

El freno de la puerta debe estar fijo al final del riel contra ellatera.

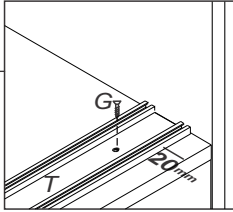

Fixar o trilho (T) a 20mm da parte front do Tampo.

Fijar el riel (T) a 20mm de la parte front del Tapa.

Secure the Rail (T) to 20mm from the part front of the Top.

10º Passo

10º Paso

10º Step

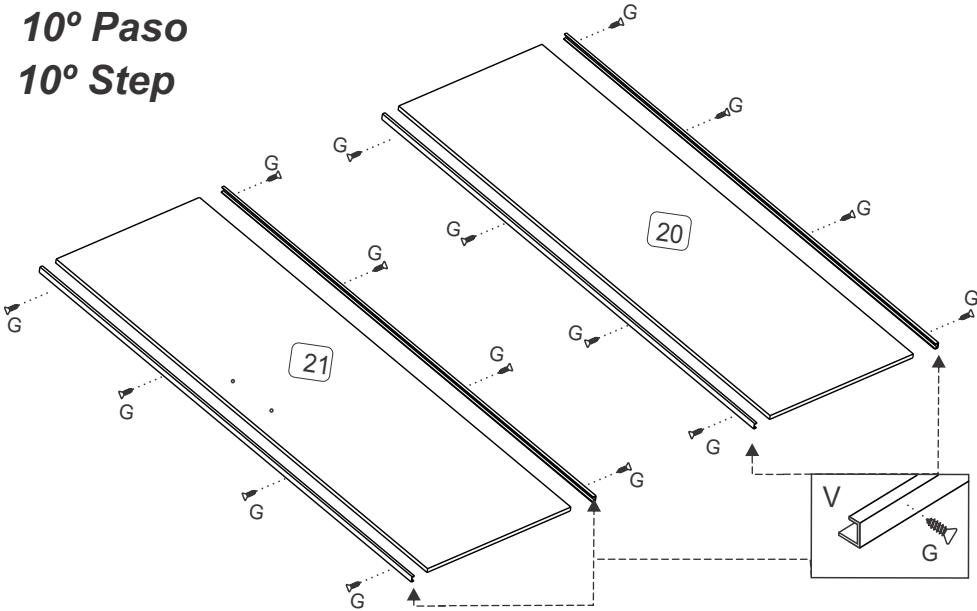

Colocando Testeira na Porta Nº 20 e 21

Poniendo el testero en la puerta Nº 20 e 21

Putting Forehead on Door Nº 20 and 21

11º Passo

11º Paso

11º Step

Definir porta Direita e Esquerda na montagem do Kit (V) na parte interna da porta.
Hacer puerta derecha e izquierda en la el armado del kit (V) en la parte interior de la puerta
Assembly the right door and left door using the kit (V) inside part of door.

O kit de portas de correr contém os parafusos próprios e somente estes devem ser usados para a fixação do mesmo exceto trilhos.

El kit de herrajes de las puertas correderas contienen los tornillos propios y solamente estos deben ser usados para la fijación de los rieles

The Sliding door kit contains the screws itself and only this should be used for fixing the same as the Rail.

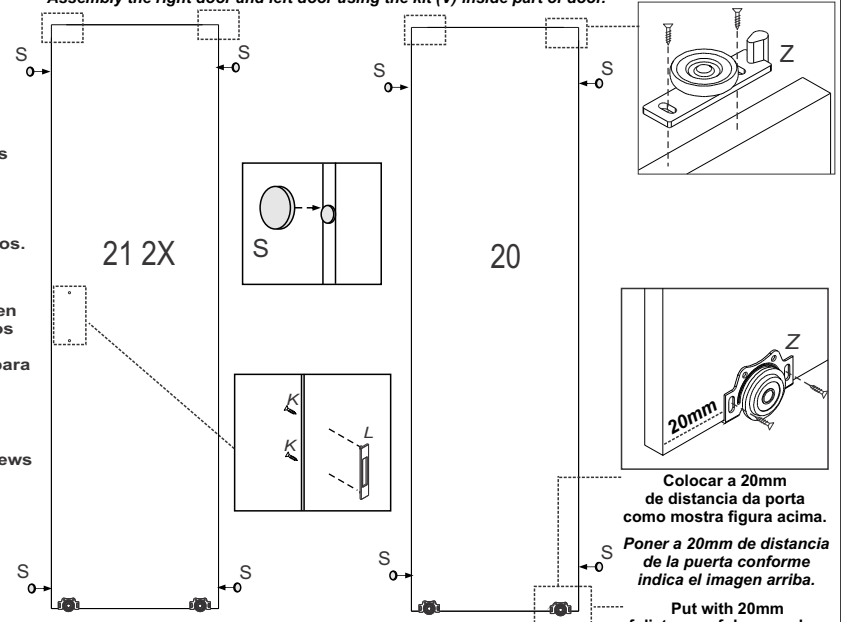

Colocar a 20mm de distancia da porta como mostra figura acima.

Poner a 20mm de distancia de la puerta conforme indica el imagen arriba.

Put with 20mm of distance of door as shown in the picture above.

12º Passo

12º Paso

12º Step

Introduza as portas no trilho superior, em seguida alinhe com o trilho inferior e aloque o rodizio em seu espaço.

Introduzca la puertas en el rieles superior, en seguida alinee con el rieles inferior y asigne en su espacio.

Insert the doors on the top rail, align with the bottom rail and alloque caster in its space.

