

F.00661

Colors / Colores / Cores / Couleurs: 328/353
19 LC

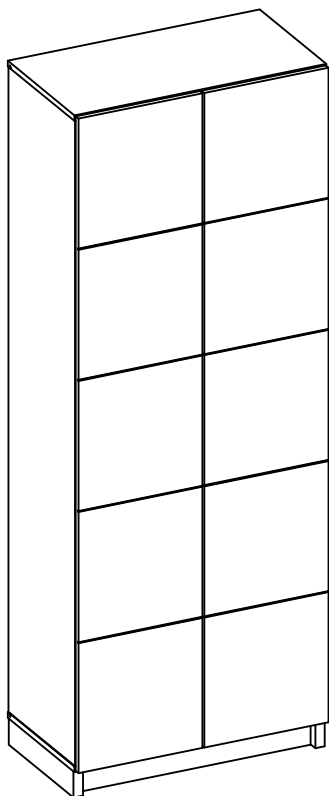

Dimensions / Dimensiones / Dimensões / Dimensions:

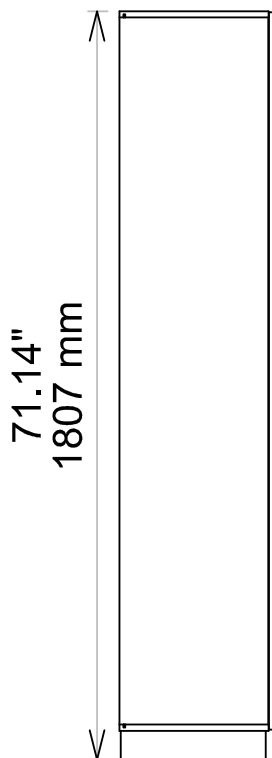
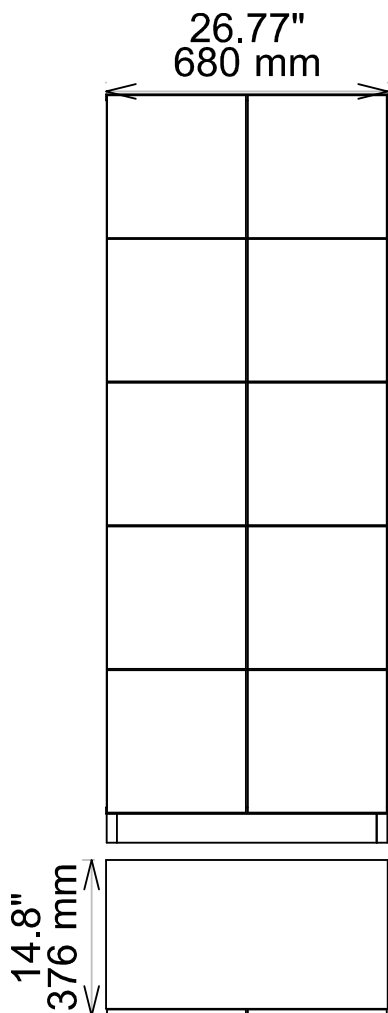

Assembly Instructions/
Instrucciones de Montaje /
Manual de Montagem /
Notice de Montage.

Introduction | Introducción | Introdução | Introduction:

- * Read the manual and follow the steps for a perfect assembly.
 - * Prepare the environment before you start. Leave the room completely clean to start the assembly.
 - * Use the carton of the box as a protection layer to separate and protect the parts in order to avoid damages. Image 01.
 - * Don't install it in areas that may be damp, with infiltrations.
- * Observe cuidadosamente el manual y siga estrictamente los pasos de montaje.
- * Antes de comenzar prepare el ambiente, dejando completamente limpio y con buen espacio para iniciar el montaje del producto.
 - * Utilice el cartón del propio embalaje, así como la protección de manta aislante para separar y apoyar las piezas retiradas de la caja. Forra el área de montaje con la manta aislante, así evita avería en la piezas durante el proceso de montaje. Image 01.
 - * No instalar en superficies húmedas, o con infiltraciones.
- * Observe atentamente o manual e siga rigorosamente os passos de montagem.
- * Antes de começar prepare o ambiente, deixando completamente limpo e com bom espaço para iniciar a montagem do produto.
 - * Use o papelão da embalagem própria, bem como proteção de manta isolante para separar e apoiar as peças removidas da caixa. Alinhe a área de montagem com o cobertor isolante, evitando assim danos nas peças durante o processo de montagem 01.
 - * Não instale em superfícies úmidas.
- * Lisez et souvez rigoureusement les indications décrites dans ce manuel pour une correcte installation du produit.
- * Choisissez un emplacement propre et adéquat avant de commencer l'installation.
 - * Utilisez le carton d'emballage comme protection et placez les pièces sur lui por éviter les dommages pendant le montage. Figure 01.
 - * Ne pas installer sur une surface humide, avec des infiltrations.

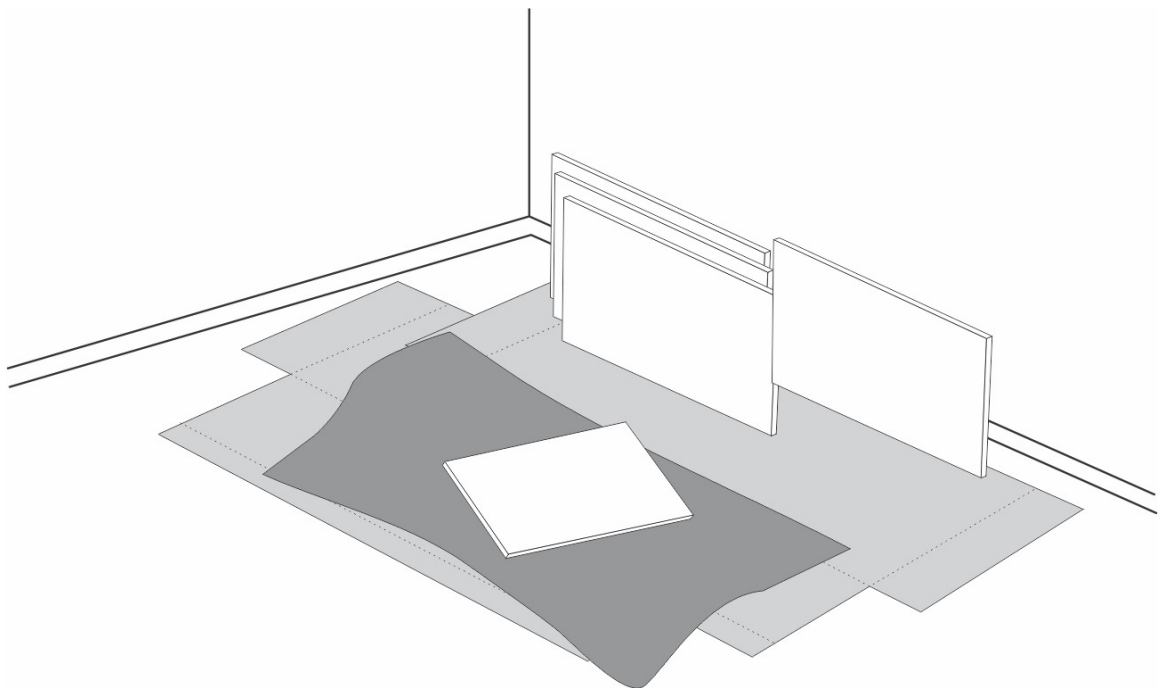

* Before beginning the assembly check all components with the parts list, separate hardware by type and assemble the furniture lying down.

* Antes de comenzar el montaje chequea todos los componentes con la lista de piezas, separe los herrajes por tipo y arma el mueble acostado.

* Antes de iniciar a montagem, verifique todos os componentes com a lista de peças, separe os acessórios por tipo e monte o móvel deitado.

* Avant de commencer le montage, vérifiez tous les composants à l'aide de la liste de pièces, séparez les accessoires selon le type et faire le montage avec le meuble couché.

* The parts come with their code stamped on.

* Los códigos de las piezas están sellados en las mismas.

* As peças vêm com código estampado.

* Le code est imprimé sur chaque pièce.

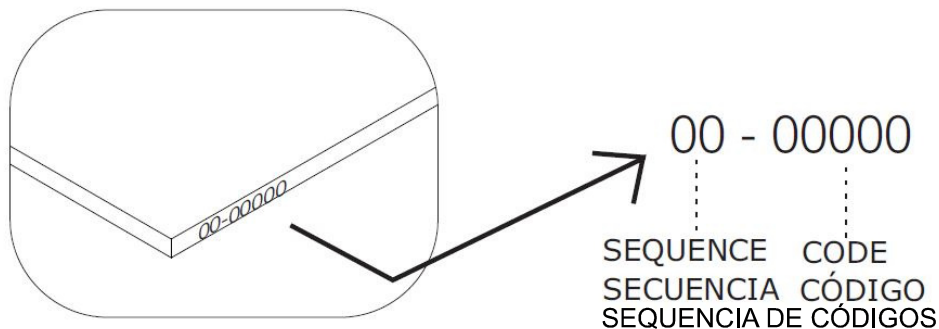

Tools / Herramientas / Ferramentas / Outils

BORRACHA / RUBBER / CAUCHO
MARTEAU EN CAOUTCHOUC

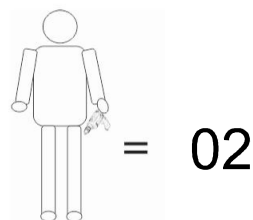
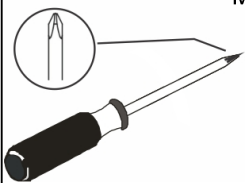

Hardwares / Accesorios / Acessórios / Ferrures de Fixation



(A) = 40



(B) = 07



(C) = 11

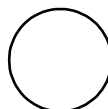

(D) = 11

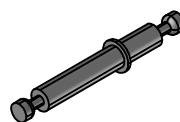

(E) = 02

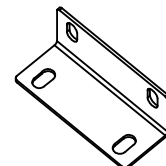

(F) = 08



(G) = 78



(H) = 16



(I) = 01

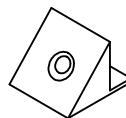

(J) = 18

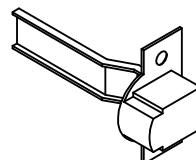

(K) = 06

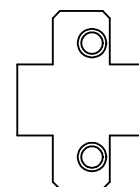

(L) = 06

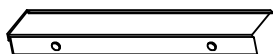

(M) = 02



(N) = 03



(O) = 04

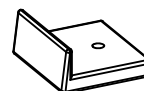

(P) = 04

(02)

PARTS / PIEZAS / PEÇAS / PIÉCES

SEQUENCE/SECUENCIA/SEQUÊNCIA	CODE/CODIGO/CÓDIGO	DESCRIPTION/DESCRIPCIÓN/DESCRIÇÃO	QTY/CANTIDADE/QUANTIDADE
01	90084	BACK/FRONT SKIRTING Rodapié Frontal/Trasero Rodape Frontal/Traseiro Plinthe Frontal Arrière	2
02	90085	RIGHT/LEFT SKIRTING Rodapié Derecho/Izquierdo Rodape Direito/Esquerdo Plinthe Droit/Gauche	2
03	90088	BASE	1
04	90091	TOP Cubierta Tampo Chapeau	1
05	90099	SHELF Repisa Prateleira Étagere	4
06	90104	BACKGROUND Fondo Fundo Arrière	2
07	90105	LEFT SIDE Lado Izquierdo Lateral Esquerda Côté Gauche	1
08	90106	RIGHT SIDE Lado Derecho Lateral Direita Côté Droit	1
09	90107	DIVISION Divisoría Divisória Cloison	1
10	90108	PORTABLE SHELF Repisa Móvil Prateleira Móvel Étagere Mobile	4
11	90109	LEFT DOOR Puerta Izquierda Porta Esquerda Porte Gauche	1
12	90110	RIGHT DOOR Puerta Derecha Porta Direita Porte Droite	1

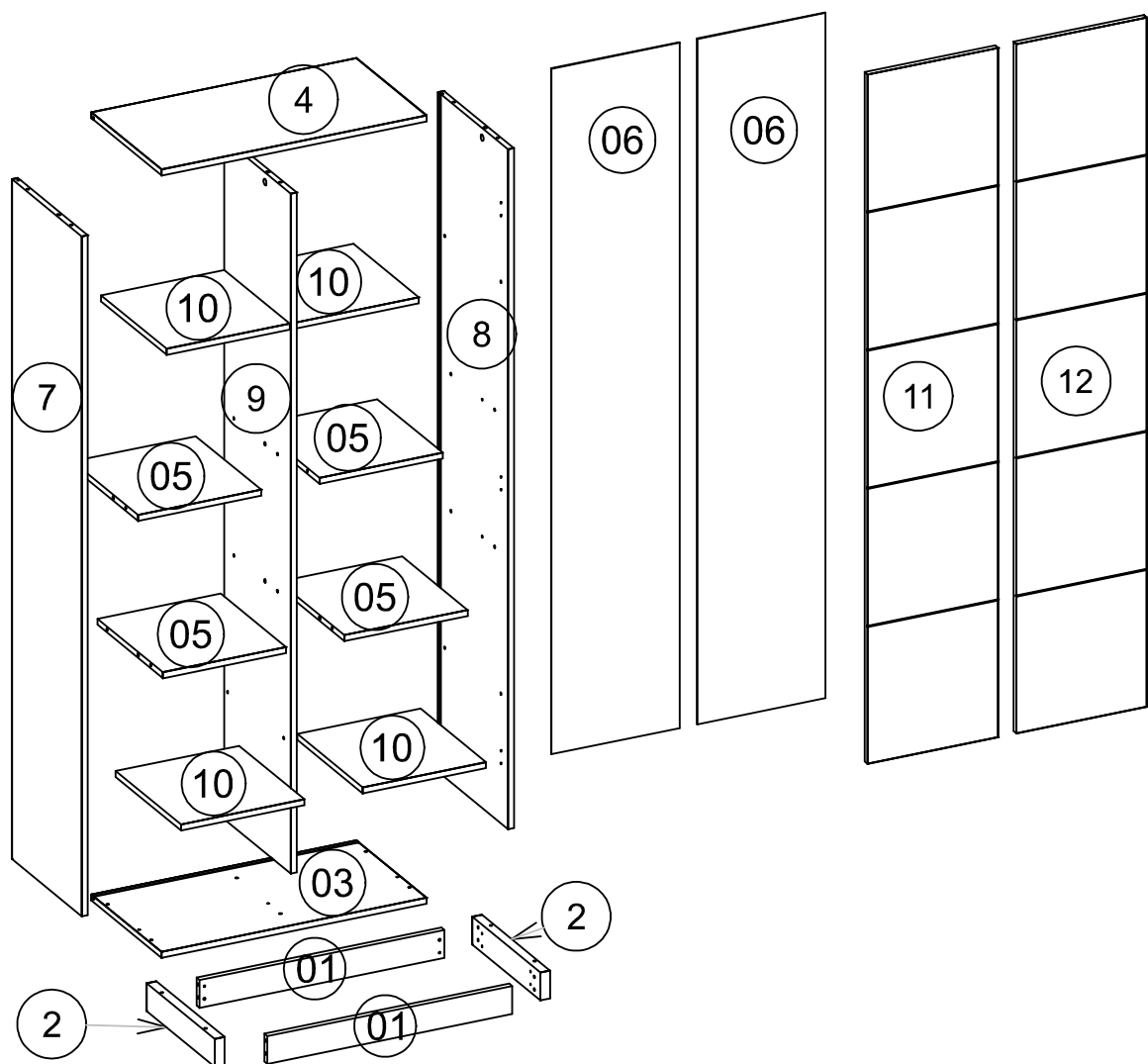

* Before starting, you have to know:

* Antes de empezar, necesitas saber:

* Antes de começar você precisa saber:

* Avant de commencer, vous devez savoir:

() You should always fix the dowel until the end using a rubber hammer.

* Deves siempre fijar ese accesorio hasta el final usando un martillo de caucho.

* Fixar o pino até o final usando um martelo de borracha.

* Vous devez toujours fixer complètement la cheville avec un marteau en caoutchouc.

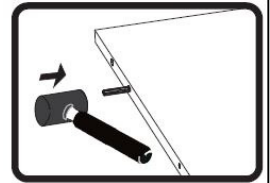



() You must screw this hardware using an electric drilling machine or phillips screwdriver only in the 0,196 inches hole (the smaller hole).

* Deves siempre fijar ese accesorio usando un taladrador eléctrico o llave phillips solamente en el agujero de 5mm.

* Parafusar o acessório usando uma parafusadeira ou uma chave de fenda phillips. Furo de 0,196 polegadas (o furo menor).

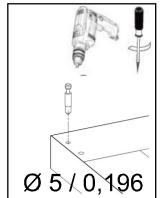
* Vous devez visser l'accessoire avec une visseuse ou un tournevis (trou de 0,196 pouces ou plus petit)



() Always fix this hardware with the arrow faced to the hole.

* Deves siempre fijar ese accesorio con la seta hacia el agujero.

* Sempre fixar este acessório com a flecha voltada para o furo.

* La flèche de cet accessoire doit être toujours dirigée au trou.



STEP/PASO/PASSO/ÉTAPE 01

* Insert hardware "A" on the extremities of the part 08, "B", "C", "G", "L" and "H" on the face.

* Encaja los accesorios "A" en los extremos de la pieza 08, "B", "C", "G", "L" y "H" en las caras.

* Insira o acessório "A" na extremidade da peça 08, "B", "C", "G", "L" and "H" na face.

* Fixez la ferrure "A" dans les extrémités de la pièce 08 et les ferrures "B", "C", "G", "L" et "H" dans le côté.

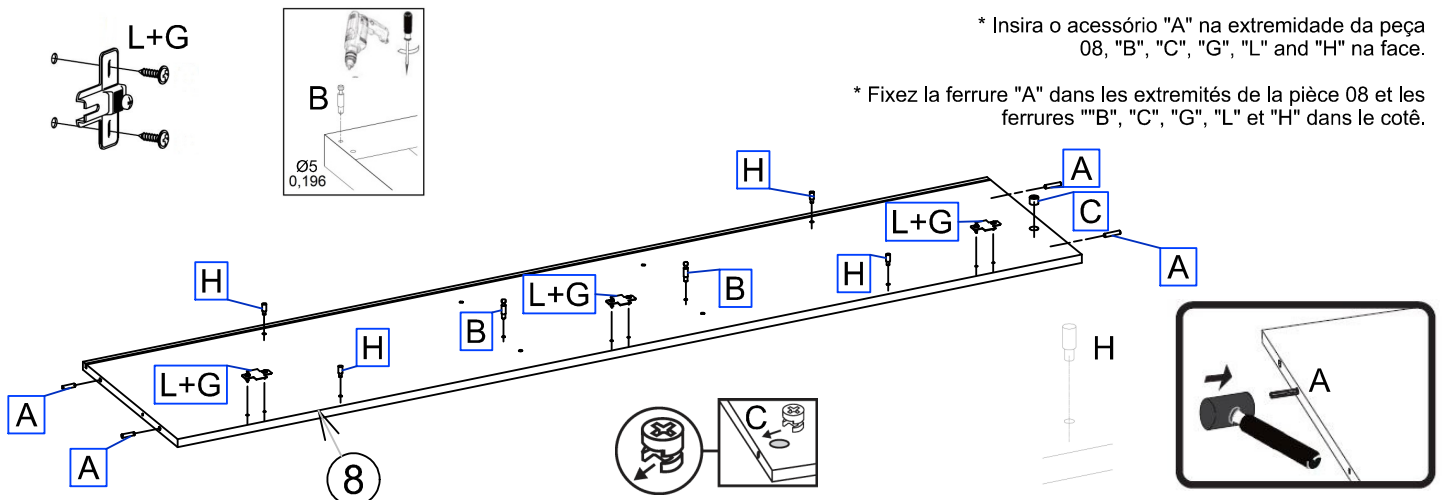

STEP/PASO/PASSO/ÉTAPE 02

* Insert hardware "A" on the extremities of the part 07, "B", "C", "G", "L" and "H" on the face.

* Insira os acessórios "A" na extremidade da peça 07, "B", "C", "G", "L" and "H" na face.

* Encaja los accesorios "A" en los extremos de la pieza 07, "B", "C", "G", "L" y "H" en las caras.

* Fixez la ferrure "A" dans les extrémités de la pièce 07 et les ferrures "B", "C", "G", "L" et "H" dans le côté.

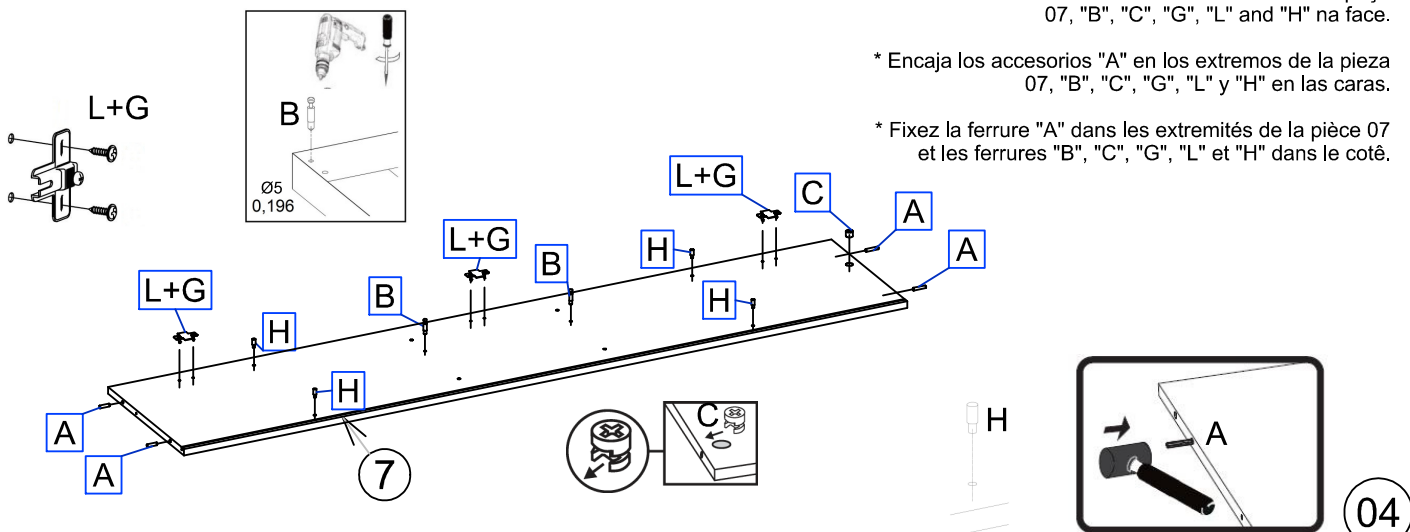

STEP/PASO/PASSO/ÉTAPE 03

* Insert hardware "A" on the extremities of the part 09, "C", "E" and "H" on the face.

* Encaja los accesorios "A" en los extremos de la pieza 09, "C", "E" y "H" en las caras.

* Insira os acessórios "A" nas extremidades da peça 09, "C", "E" e "H" na face.

* Fixez la ferrure "A" dans les extrémités de la pièce 09 et les ferrures "C", "E" et "H" dans le côté.

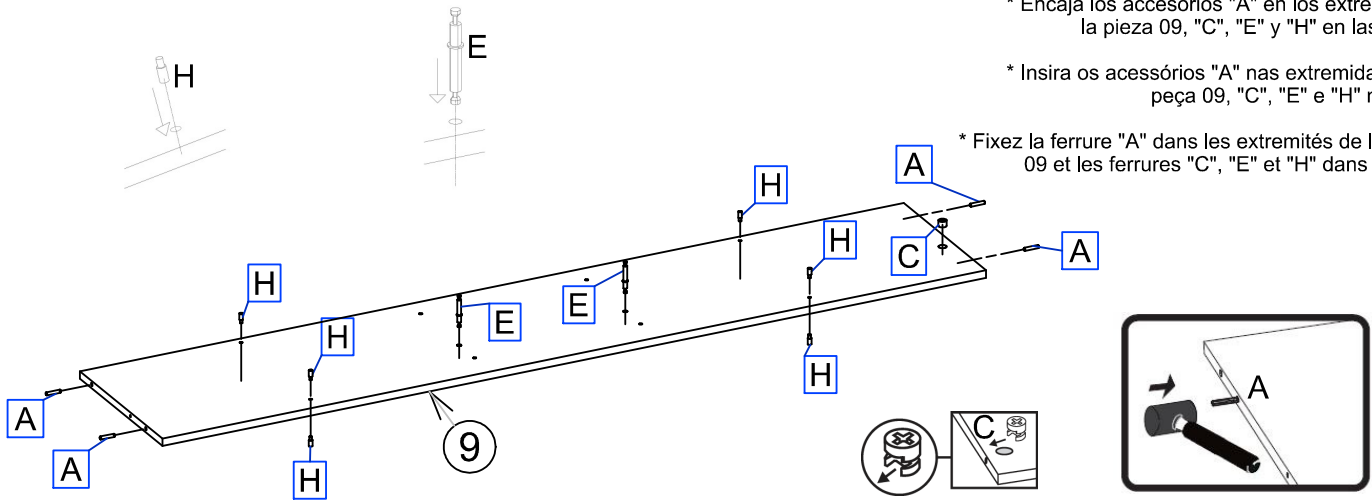

STEP/PASO/PASSO/ÉTAPE 04

* Insert hardware "A" on the extremities of the part 02.

* Encaja los accesorios "A" en los extremos de la pieza 02.

* Insira os acessórios "A" nas extremidades da peça 02.

* Fixez la ferrure "A" dans les extrémités de la pièce 02.

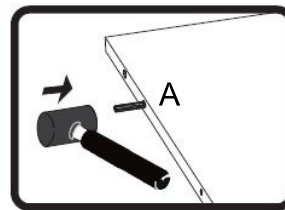
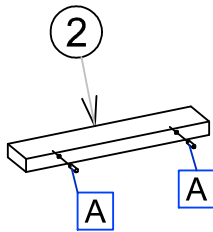

STEP/PASO/PASSO/ÉTAPE 05

* Insert hardware "A" on the extremities of the part 05 and "C" on the face.

* Encaja los accesorios "A" en los extremos de la pieza 05 y "C" en las caras.

* Insira os acessórios "A" nas extremidades da peça 05 e "C" na face.

* Fixez la ferrure "A" dans les extrémités de la pièce 05 et les ferrures "C" dans le côté.

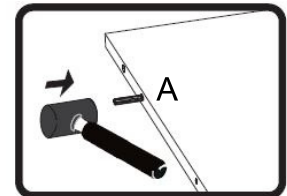
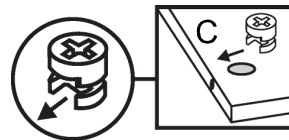
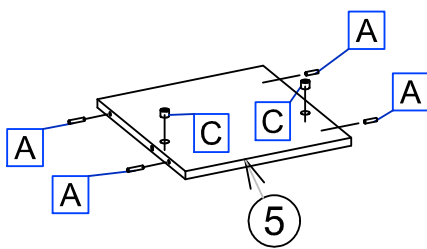

STEP/PASO/PASSO/ÉTAPE 06

* Insert hardware "A" on the extremities of the part 01.

* Encaja los accesorios "A" en los extremos de la pieza 01.

* Insira os acessórios "A" nas extremidades da peça 01.

* Fixez la ferrure "A" dans les extrémités de la pièce 01.

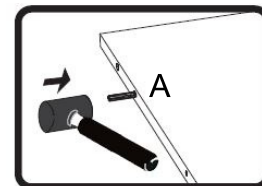
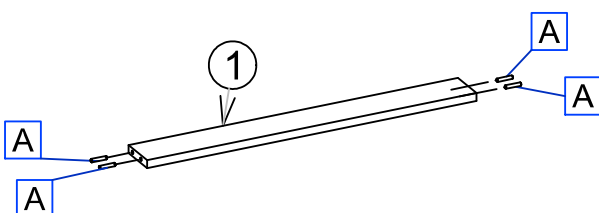

STEP/PASO/PASSO/ÉTAPE 07

* Insert hardware "G", "K" and "M" on the face of the part 11.

* Encaja los accesorios "G", "K" y "M" en las caras de la pieza 11.

* Insira os acessórios "G", "K" e "M" na face da peça 11.

* Fixez les ferrures "G", "K" et "M" dans le côté de la pièce 11.

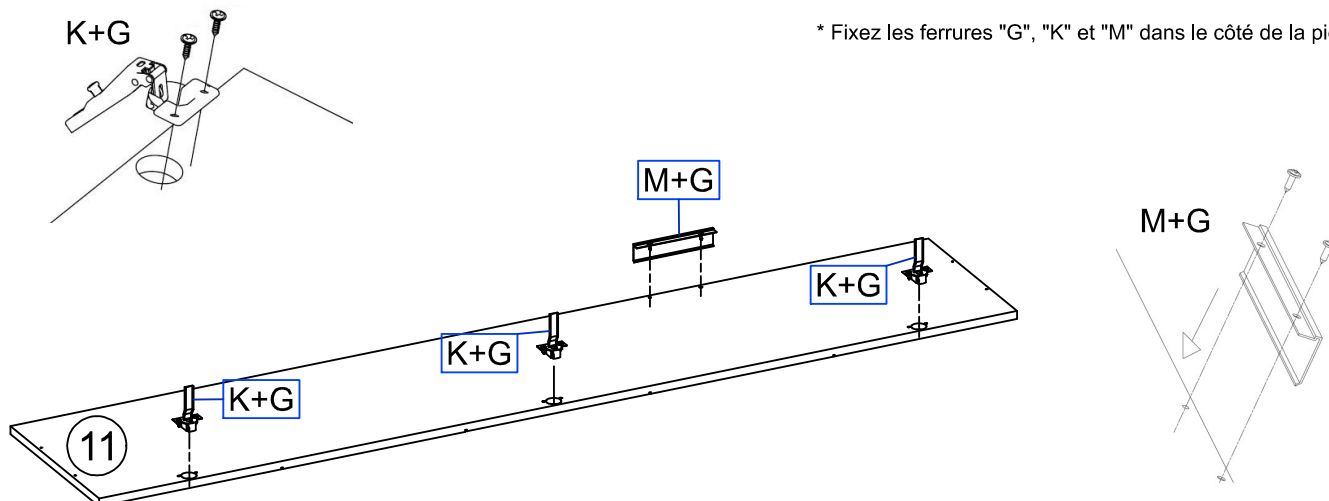

STEP/PASO/PASSO/ÉTAPE 08

* Insert hardware "G", "K" and "M" on the face of the part 12.

* Encaja los accesorios "G", "K" y "M" en las caras de la pieza 12.

* Insira os acessórios "G", "K" e "M" na face da peça 12.

* Fixez les ferrures "G", "K" et "M" dans le côté de la pièce 12.

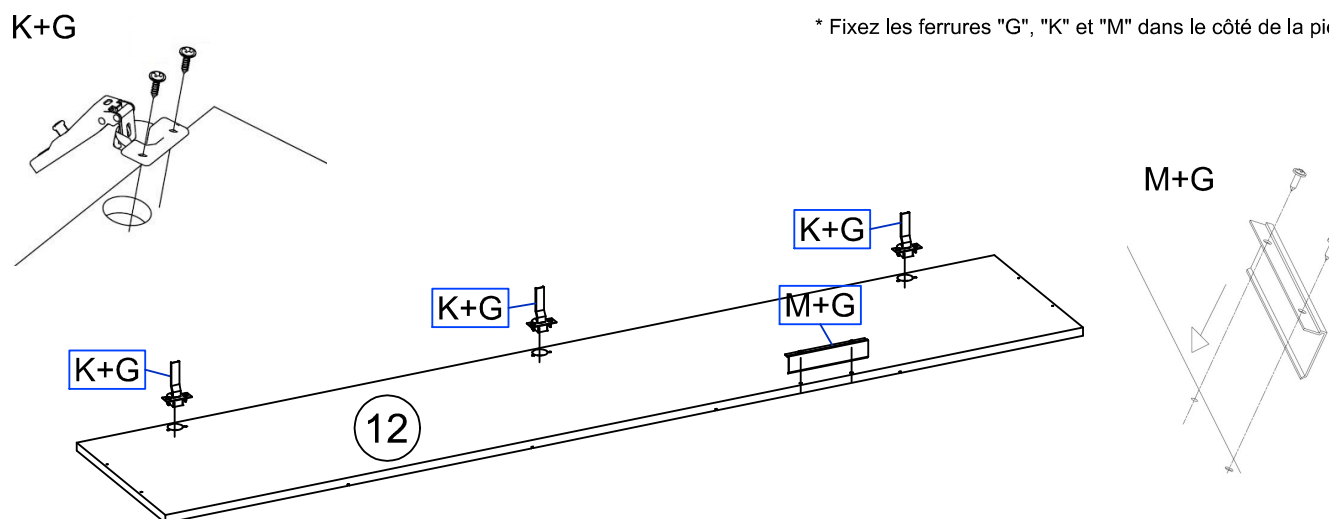

STEP/PASO/PASSO/ÉTAPE 09

* Insert hardware "B" on the face of the part 04.

* Encaja los accesorios "B" en las caras de la pieza 04.

* Insira os acessórios "B" na face da peça 04.

* Fixez la ferrure "B" dans le côté de la pièce 04.

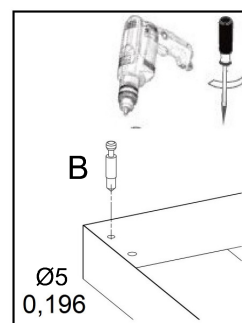
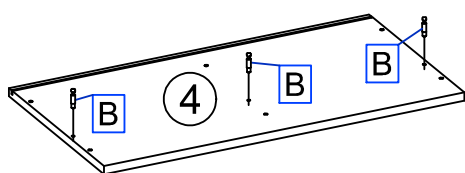

STEP/PASO/PASSO/ÉTAPE 10

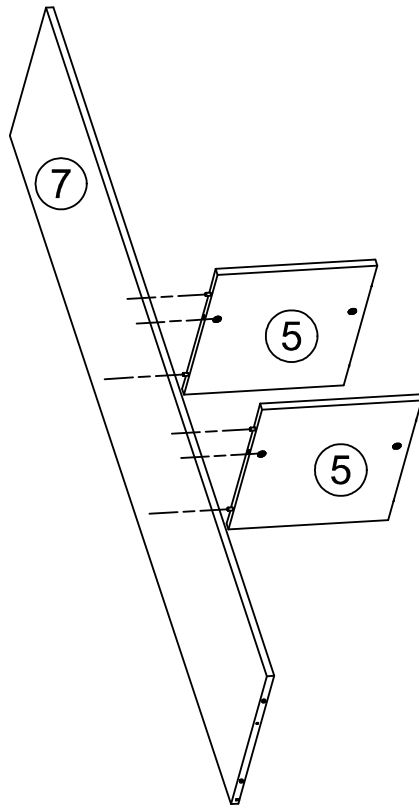

* Attach parts 05 to the part 07 according to the image. Then screw the nuts "C" and finish with cover taps "D".

* Enganche las piezas 05 en la pieza 07 de acuerdo con la imagen. Atonillar las tuercas "C" y terminar con las tapas "D".

* Conecte a peça 05 na peça 07 de acordo com a imagem. Em seguida parafuse as porcas "C" e cole os tapa furo "D".

* Fixez les pièces 05 dans la pièce 07 comme montre la figure. Ensuite vissez avec écrous "C" et mettez les cache trous "D".

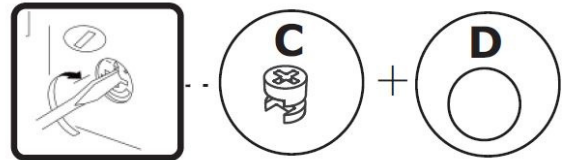
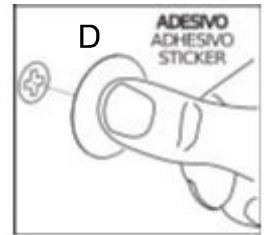

STEP/PASO/PASSO/ÉTAPE 11

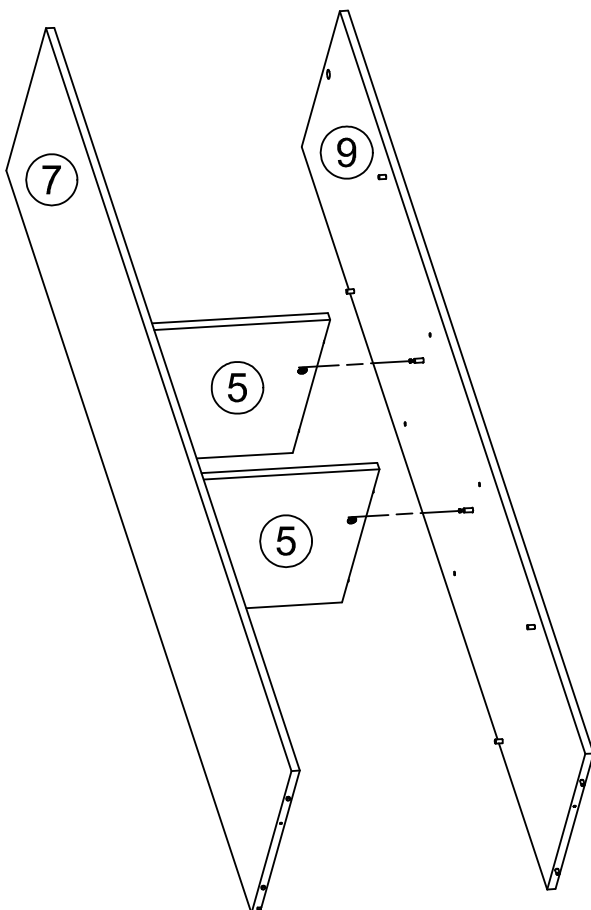

* Attach part 09 to the parts 05 according to the image. Then screw the nuts "C" and finish with cover taps "D".

* Enganche la pieza 09 en las piezas 05 de acuerdo con la imagen. Atonillar las tuercas "C" y terminar con las tapas "D".

* Conecte a peça 09 nas peças 05 de acordo com a imagem. Em seguida parafuse as porcas "C" e cole os tapa furo "D".

* Fixez la pièce 09 dans les pièces 05 comme montre la figure. Ensuite vissez avec écrous "C" et mettez les cache trous "D".

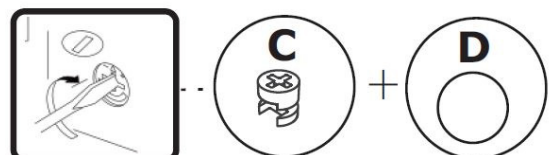
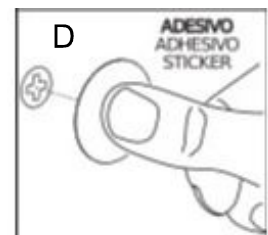

STEP/PASO/PASSO/ÉTAPE 12

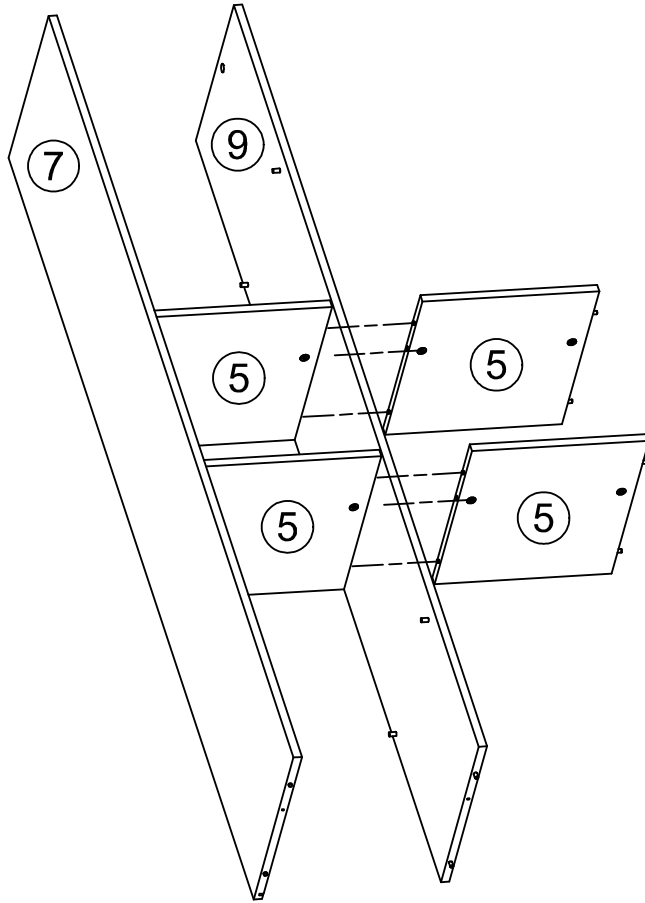

* Attach parts 05 to the part 09 according to the image. Then screw the nuts "C" and finish with cover taps "D".

* Enganche las piezas 05 en la pieza 09 de acuerdo con la imagen. Atonilar las tuercas "C" y terminar con las tapas "D".

* Conecte as peças 05 na peça 09 de acordo com a imagem. Em seguida parafuse as porcas "C" e cole os tapa furo "D".

* Fixez les pièces 05 dans la pièce 09 comme montre la figure. Ensuite vissez avec écrous "C" et mettez les cache trous "D".

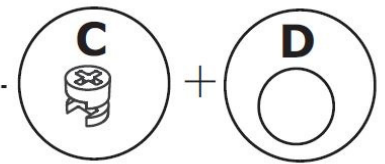
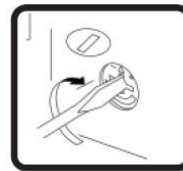

STEP/PASO/PASSO/ÉTAPE 13

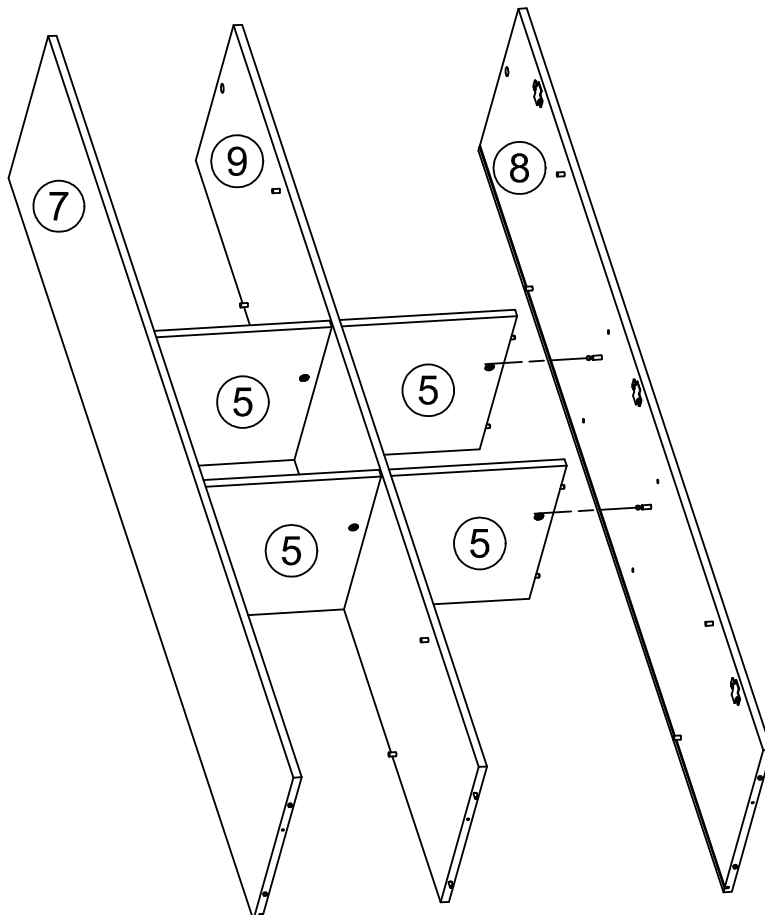

* Attach part 08 to the parts 05 according to the image. Then screw the nuts "C" and finish with cover caps "D".

* Enganche la pieza 08 en las piezas 05 de acuerdo con la imagen. Atonilar las tuercas "C" y terminar con las tapas "D".

* Conecte a peça 08 nas peças 05 de acordo com a imagem. Em seguida parafuse as porcas "C" e cole os tapa furo "D".

* Fixez la pièce 08 dans les pièces 05 comme montre la figure. Ensuite vissez avec écrous "C" et mettez les cache trous "D".

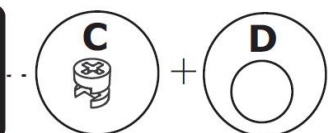
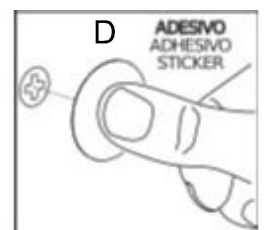

08

STEP/PASO/PASSO/ÉTAPE 14

* Attach part 04 to the part 07, 08 and 09 according to the image. Then screw the nuts "C" and finish with cover taps "D".

* Enganche la pieza 04 en la pieza 07, 08 y 09 de acuerdo con la imagen. Atonillar las tuercas "C" y terminar con las tapas "D".

* Conecte a peça 04 nas peças 07, 08 e 09 de acordo com a imagem. Em seguida parafuse as porcas "C" e cole os tapa furo "D".

* Fixez la pièce 04 dans les pièces 07, 08 et 09 comme montre la figure. Ensuite vissez avec écrous "C" et mettez les cache trous "D".

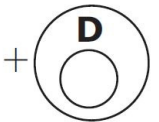
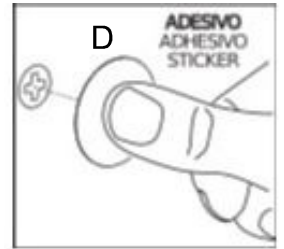
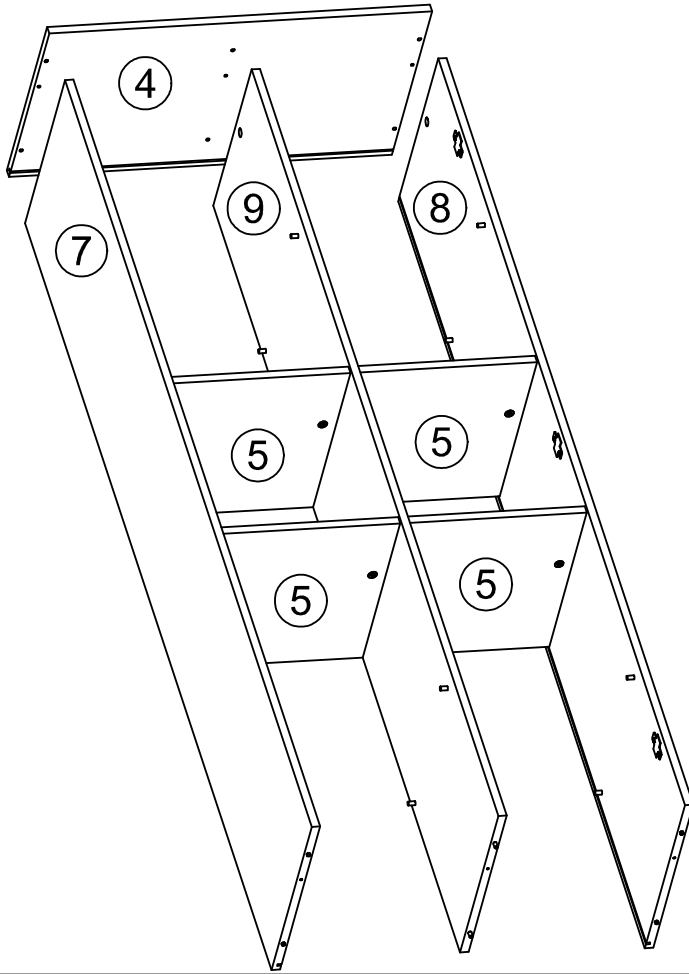

STEP/PASO/PASSO/ÉTAPE 15

* Insert the parts 06 to the trail according to the image. Use the "I" to join the 06.

* Enganche la piezas 06 en el camino de acuerdo con la imagen. Usa el "I" para unirte al 06.

* Insira as peças 06 no canal de acordo com a imagem. Utilize o acessório "I" para unir as peças 06.

* Fixez la pièce 06 dans la glissière comme montre la figure. Utilisez la ferrure "I".

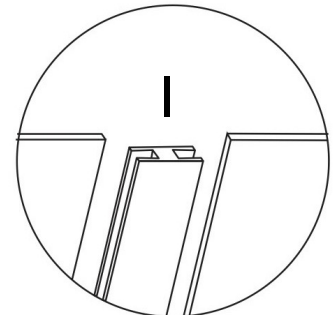
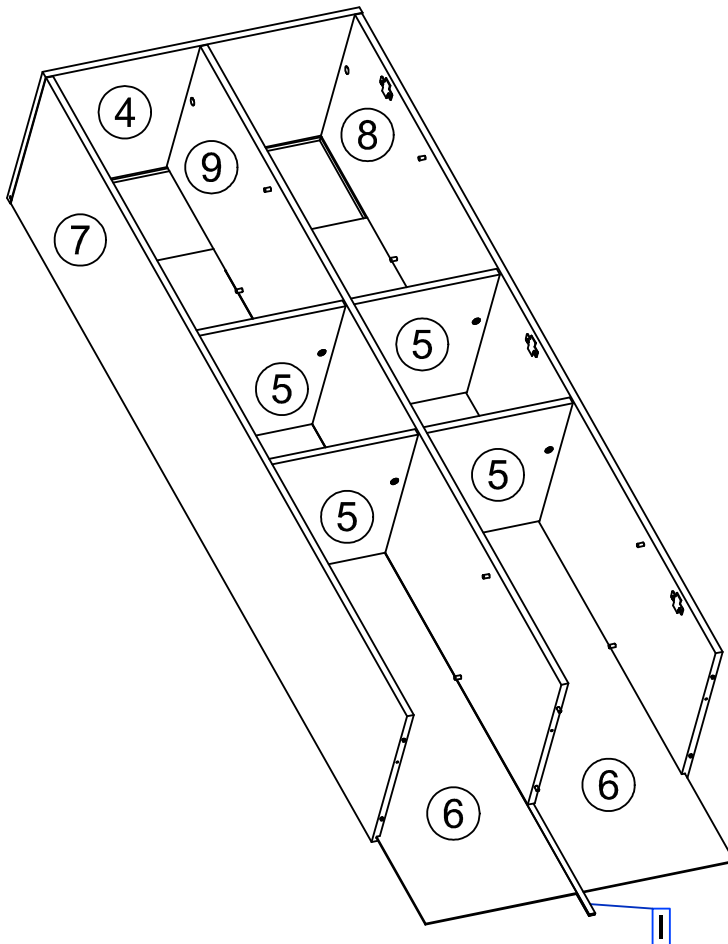

STEP/PASO/PASSO/ÉTAPE 16

* Attach part 03 to the part 07, 08 and 09 according to the image. Then screw "N".

* Enganche la pieza 03 en la pieza 07, 08 y 09 de acuerdo con la image. Atonilar "N".

* Conecte a peça 03 nas peças 07, 08 e 09 de acordo com a imagem. Em seguida parafuse "N".

* Fixez la pièce 03 dans les pièces 07, 08 et 09 comme montre la figure. Ensuite vissez "N".

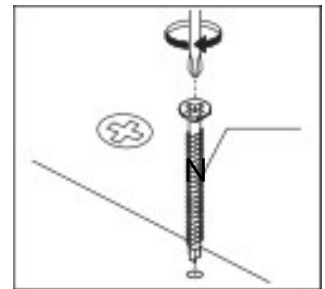
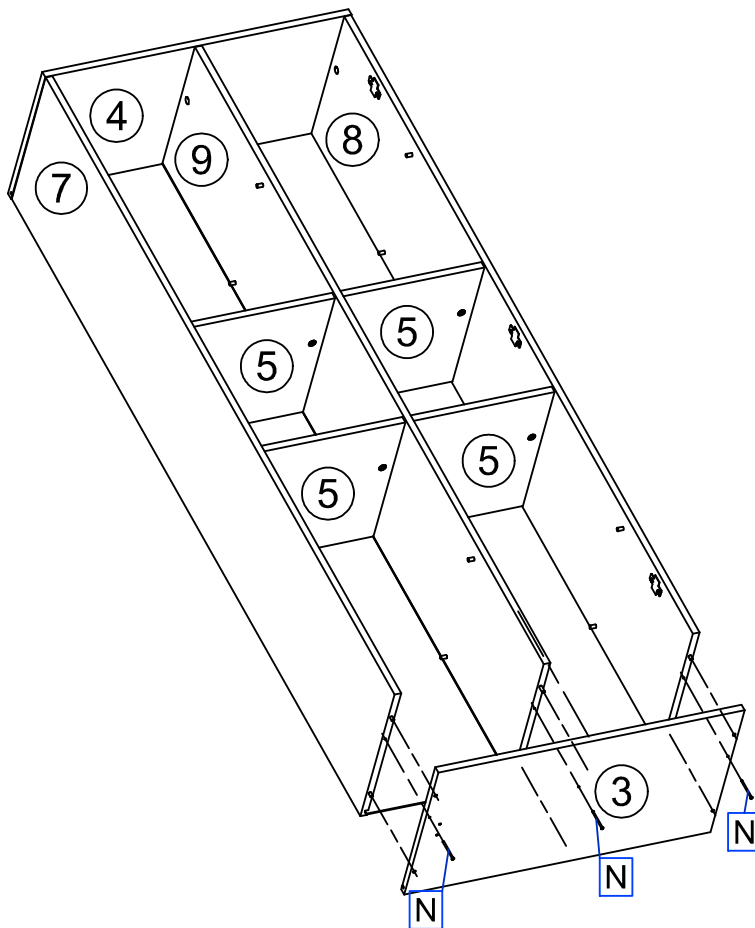

STEP/PASO/PASSO/ÉTAPE 17

* Attach the parts 02 to the parts 01 according to the image. Then screw "G" in the angle connector "F".

* Enganche las piezas 02 en las piezas 01 de acuerdo con la imagen. Atonille "G" en el conector angular "F".

* Conecte as peças 02 nas peças 01 de acordo com a imagem. Em seguida parafuse "G" na cantoneira angular "F".

* Fixez les pièces 02 dans les pièces 01 comme montre la figure. Ensuite vissez "G" dans le connecteur coudé "F".

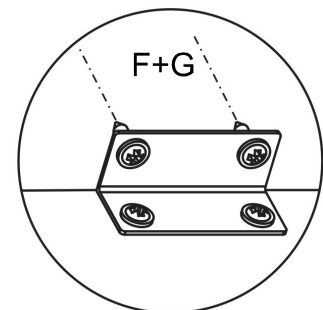
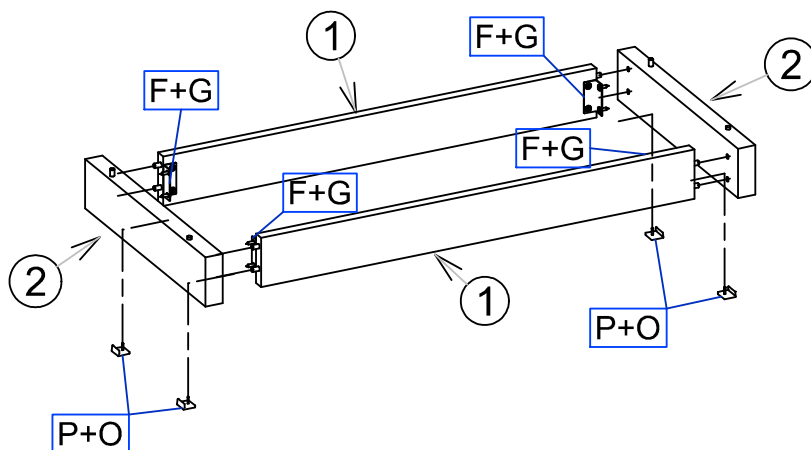

STEP/PASO/PASSO/ÉTAPE 18

* Attach parts 01 and 02 to the part 03 according to the image. Then screw "G" in the angle connector "F".

* Enganche las piezas 01 y 02 en la pieza 03 de acuerdo con la imagen. Atornille "G" en el conector angular "F".

* Conecte as peças 01 e 02 na peça 03, de acordo com a imagem. Em seguida parafuse "G" na contoneira angular "F".

* Fixez les pièces 01 et 02 dans les pièces 03 comme montre la figure. Ensuite vissez "G" dans le connecteur coudé "F".

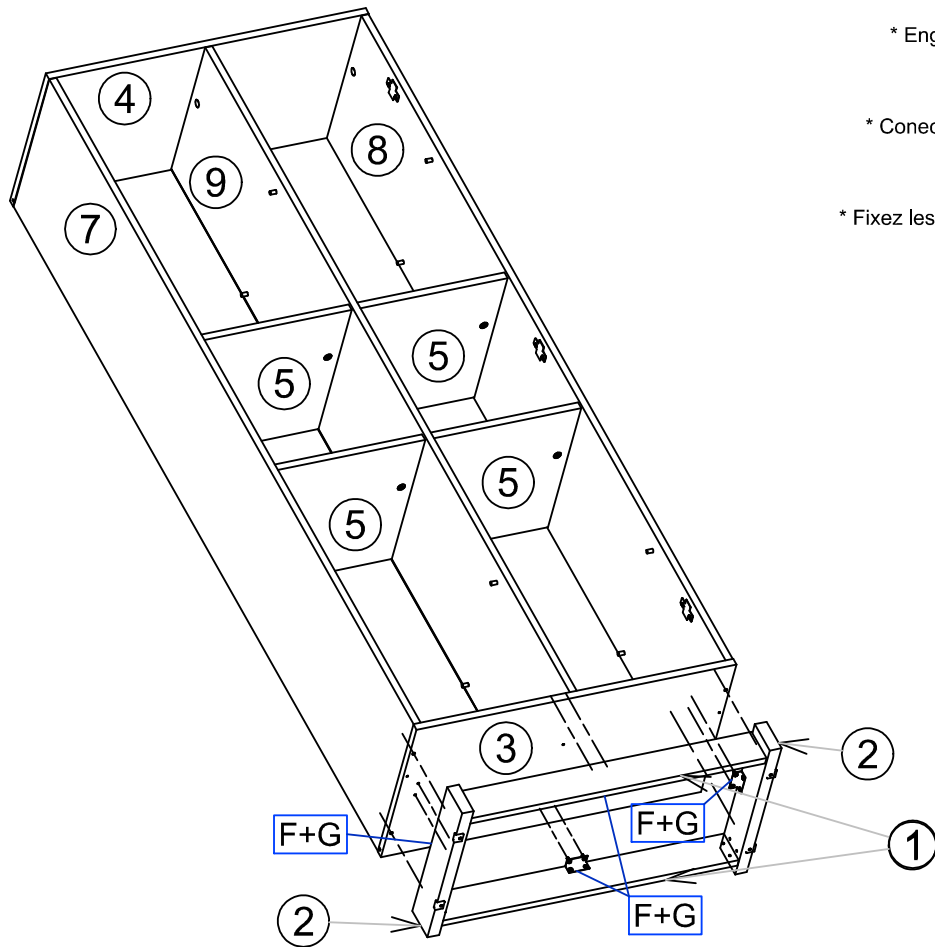

STEP/PASO/PASSO/ÉTAPE 19

* Place parts 10 between the parts 07 - 09 and 08 - 09 according to the image.

* Coloque las partes 10 entre las partes 07 - 09 y 08 - 09 de acuerdo con la imagen.

* Coloque as peças 10 entre as peças 07 - 09 e 08 - 09 de acordo com a imagem.

* Mettez les pièces 10 entre les pièces 07-09 et 08-09 comme montre la figure.

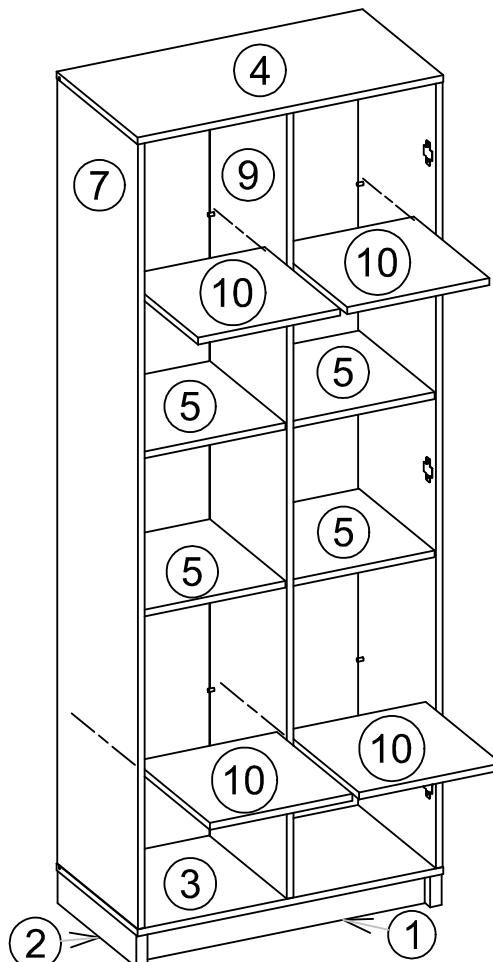

STEP/PASO/PASSO/ÉTAPE 20

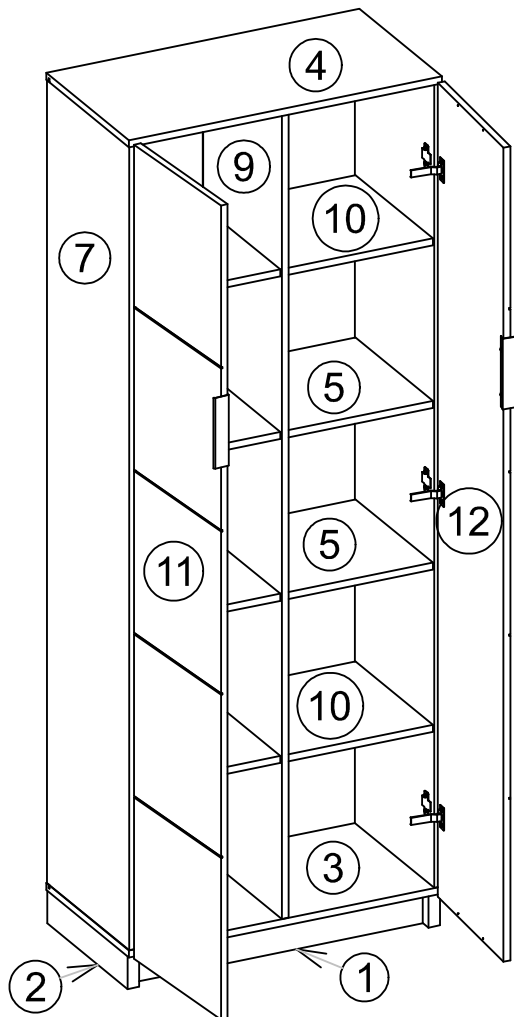

* Attach parts 11 and 12 to the parts 07 and 08 through the join of the hardware "L" and "K" according to the image.

* Enganche las piezas 11 y 12 en las piezas 07 y 08 a través de la unión de los accesorios "L" y "K" de acuerdo con la imagen.

* Conecte as peças 11 e 12 nas peças 07 e 08 através da junção dos acessórios "L" e "K" de acordo com a imagem.

* Assemblez les pièces 11 et 12 avec les pièces 07 et 08 à travers de la jonction des ferrures "L" et "K" comme montre la figure.

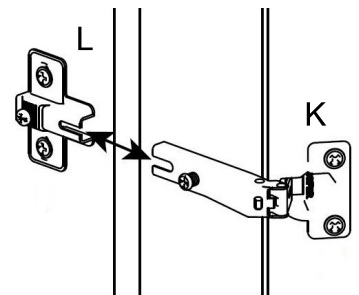

STEP/PASO/PASSO/ÉTAPE 21

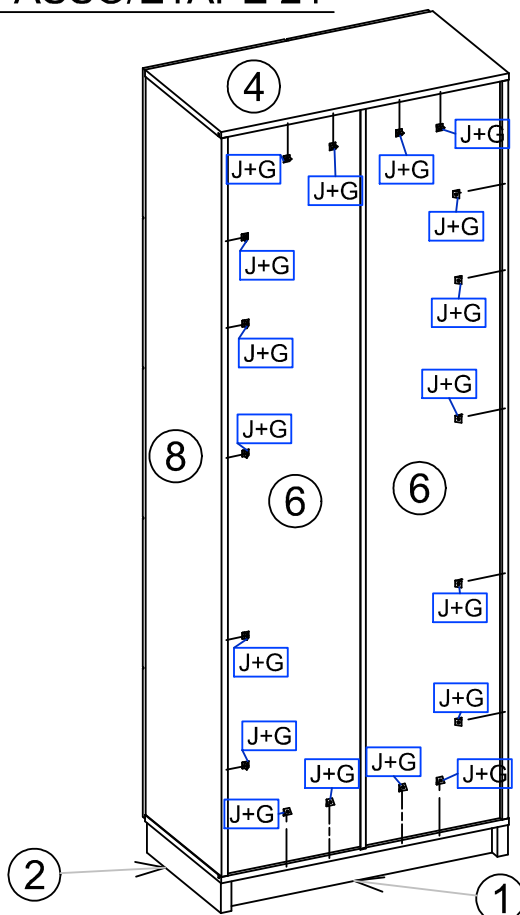

* Insert hardware "J" and "G" on the face of the parts 06 according to the image.

* Encaja los accesorios "J" y "G" en las caras de la pieza 06 de acuerdo con la imagen.

* Insira o acessório "J" e "G" na face das peças 06 de acordo com a imagem.

* Fixez les ferrures "J" et "G" dans le côté des pièces 06 comme montre la figure.

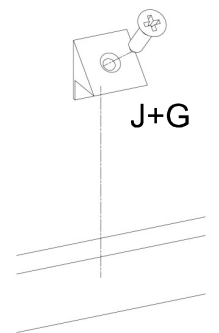

STEP/PASO/PASSO/ÉTAPE 22

Warning (tipover sistem)

Atención (Sistema anti-vuelco)

Atenção (Sistema anti-tombamento)

Attention (Système anti-basculement)

* Attach the hardware Z1 using screw Z2 in the part 08. Then, drill the wall to press the wall plug Z3 in the hole, and screw Z4 to fix the mobile to the wall.

* Enganche el accesorio Z1 usando el tornillo Z2 en la pieza 08. Entóndes perfora la pared para poner los tacos Z3 en el agujero y atornille la Z4 para fijar el móvil a la pared.

* Conecte o acessório Z1 na peça 08 utilizando o parafuso Z2. Em seguida, perfure a parede, insira o acessório Z3 no orifício e aperte Z4 para fixar o móvel na parede.

* Fixez la ferrure Z1 avec vis Z2 dans la pièce 088. Ensuite, percez un trou dans le mur, insérez Z3 et vissez Z4 pour fixer le meuble dans le mur.

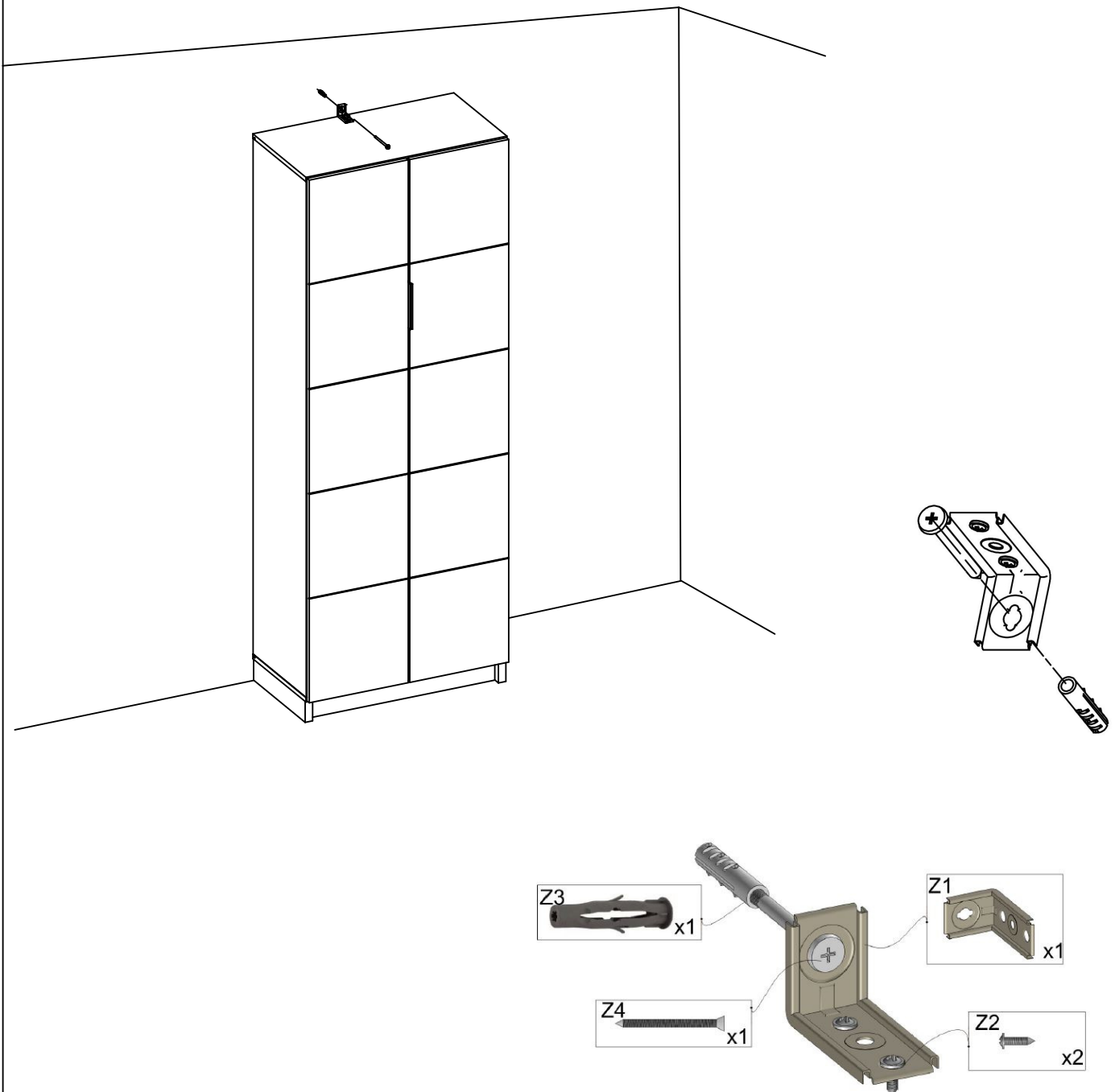

FINAL VIEW | ASPECTO FINAL | ASPECT FINAL

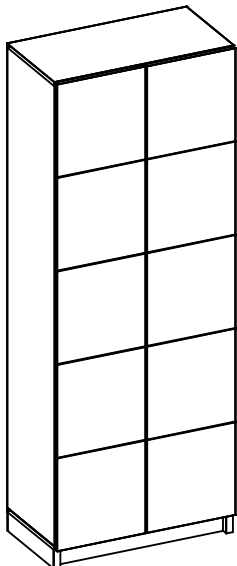

WEIGHT | PESO | PESO | POIDS

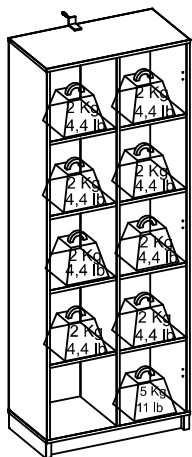

* Be aware about maximum weights shown in the assembly instruction.

* Todos los pesos máximos indicados en el manual deben ser respetados.

* Esteja ciente sobre o peso máximo indicado no manual de montagem.

* Respectez les quantités maximales indiquées dans le mode d'emploi.

EVITAR ACIDENTES | AVOID ACCIDENTS | PREVENIR ACCIDENTES

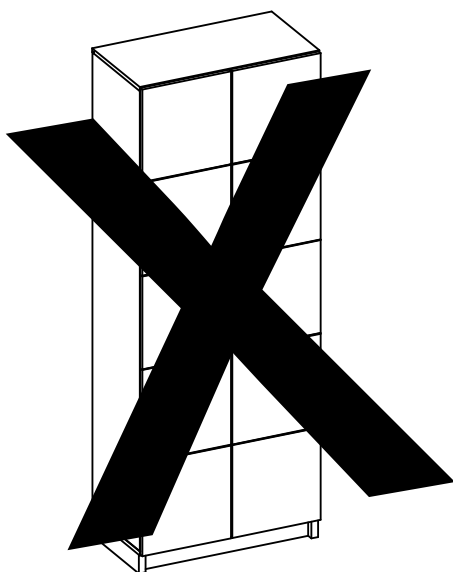

* Don't climb or lean on the furniture.

* No se suba ni se apoye en el mueble.

* Não suba ou incline-se sobre a mobilia.

* Ne pas monter / s'appuyer sur le meuble.

MAINTENANCE AND CLEANING | MANTENIMIENTO Y LIMPIEZA MANUTENÇÃO E LIMPEZA | NETTOYAGE

* For cleaning use only cloth slightly dampened in water.

* Para la limpieza utilice sólo un paño húmedo con agua.

* Para limpeza use apenas um pano levemente umedecido em água.

* Pour le nettoyage, utilisez un chiffon humide. Evitez l'utilisation de produits de nettoyage.