

Balcão/Mostrador/Counter

ENEZA

BC-4205

MANUAL DE MONTAGEM INSTRUCCIONES DE ARMADO ASSEMBLY INSTRUCTIONS

Instruções para a montagem do produto: Product assembly instructions: Instrucciones de montaje del Producto:

Separe as peças e acessórios de maneira organizada.

Separate the parts and accessories in an organized way.
Separe las piezas y accesorios de forma organizada

Forrar o chão com o papelão das embalagens.

Cover the floor with the cardboard from the pack.
Cubre el suelo con el cartón de los bultos.

É necessário duas pessoas para montar o produto.

It's necessary two people to assembly the product.
Se requiere dos personas para montar el producto.

Ferramentas necessárias(não fornecidas)

Herrajes necesarias (no incluye)

Necessary tools (not supplied)

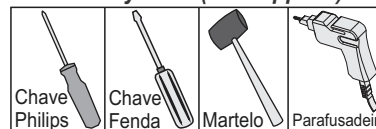

Chave
Philips

Chave
Fenda

Martelo

Parafusadeira

Ferragens/Herraje/Hardware:

330	A	Cavilhas 6 x 30 Wood Peg		23
0289	B	Parafuso 3,5 x 40 Tornillo Screw		14
----	C	Puxador VP25 com tampa 384mm Tirador Handle		03
----	D	Puxador VP25 com tampa 397mm Tirador Handle		02
0477	E	Cola Pegamento		01
0283	G	Parafuso 3,5 x 12 c/c Tornillo Screw		60
0296	H	Taxa 10 x 7 Clavo 10 x 7 Nail 10 x 7		60
151	I	Dobradiça metal Bisagra Hinge		06
0538	J	Porca cilíndrica Tuerca cilíndrica Cylindrical nut		08
0438	K	Cantoneira Esquina Cantoneira		10
-----	L	Pés Pies Feet		05
0555	M	Parafuso 5 X 50 Tornillo Screw		05
0279	N	Fixador De Costa Fixador de Espalda Fix Back		12
0744	O	Taxa 13 x 15 Clavo 13 x 15 Nail 13 x 15		08
3049	P	Corrediza slim 350 mm Rieles Slides		02
4738	Q	Cantoneira Plástica Refuerzo de plástico Plastic gusset		02
0293	R	Parafuso 3,5 x 14 CF Tornillo Screw		12
0286	T	Parafuso 3,5 x 22 c/c Tornillo Screw		02

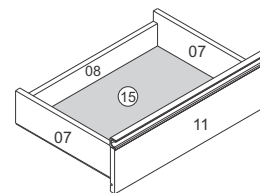
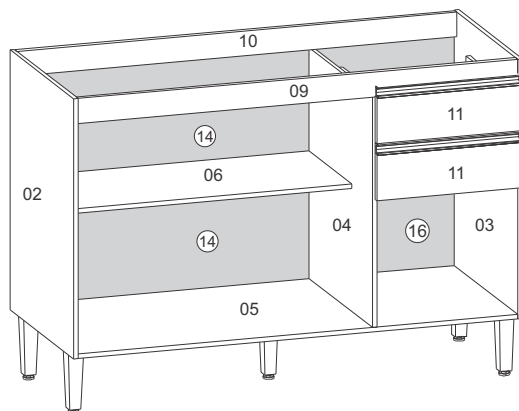
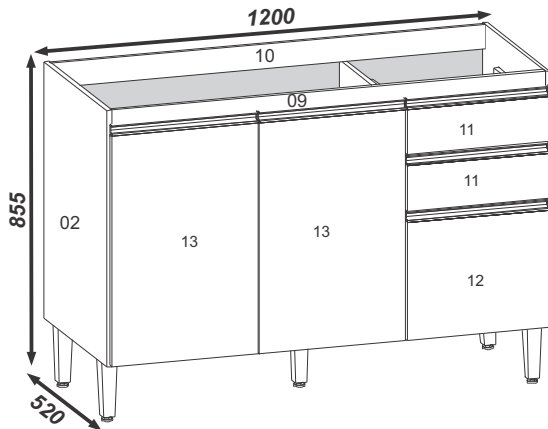

POR.

02-LATERAL ESQUERDA
03-LATERAL DIREITA
04-DIVISORIA
05-TAMPO INFERIOR
06-PRATELEIRA
07-LATERAL DE GAVETA (4X)
08-TRASEIRO DE GAVETA (2X)
09-TRAVESSA FRONTAL
10-TRAVESSA TRASEIRA
11-FRENTE DE GAVETA (2X)
12-PORTA DIREITA
13-PORTA (2X)
14-COSTA (2X)
15-FUNDO DE GAVETA (2X)
16-COSTA ESQUERDA

ENG.

02-LEFT SIDE
03-RIGHT SIDE
04-LEFT DIVISION
05-LOWER TOP
06-SHELF
07-DRAWER SIDE (4x)
08-DRAWER BACK (2x)
09-FRONT TRAVESER
10-BACK TRAVESER
11-DRAWER FRONT(2x)
12-RIGHT DOOR
13-DOOR (2x)
14-BACK PANEL (2x)
15-DRAWER BOTTOM (2x)
16-LEFT BACK PANEL

ESP.

02-LATERAL IZQUIERDA
03-LATERAL DERECHA
04-DIVISION IZQUIERDA
05-TAPA INFERIOR
06-ESTANTE
07-LATERAL DEL CAJÓN (4x)
08-TRASERO DEL CAJÓN (2x)
09-TRAVESSAÑO FRONTAL
10-TRAVESSAÑO TRASERO
11-FRENTE DEL CAJÓN (2x)
12-PUERTA DERECHA
13-PUERTA (2x)
14-DORSO (2x)
15-FONDO DEL CAJÓN (2x)
16-DORSO IZQUIERDA

Dimensões Peças Prontas

Dimensiones de Las Piezas Prontas
Dimensions Ready Part

02-680 X 500 X 12
03-680 X 500 X 12
04-588 X 499 X 12
05-1176 X 499 X 12
06-788 X 338 X 12
07-338 X 95 X 12
08-328 X 65 X 12
09-1176 X 80 X 15
10-1176 X 80 X 15
11-384 X 125 X 15
12-384 X 280 X 15
13-586 X 397 X 15
14-800 X 302 X 3
15-350 X 341 X 3
16-390 X 604 X 3



5º Passo
5º Paso
5º Step

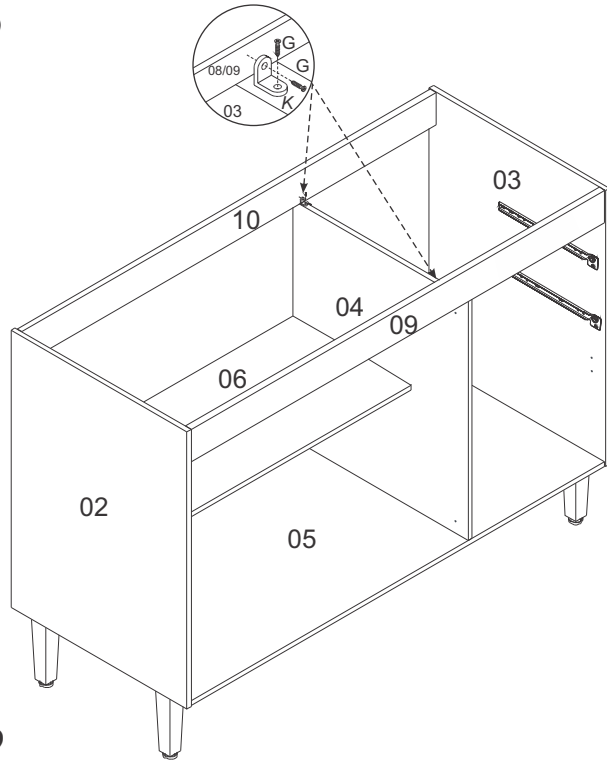

6º Passo
6º Paso
6º Step

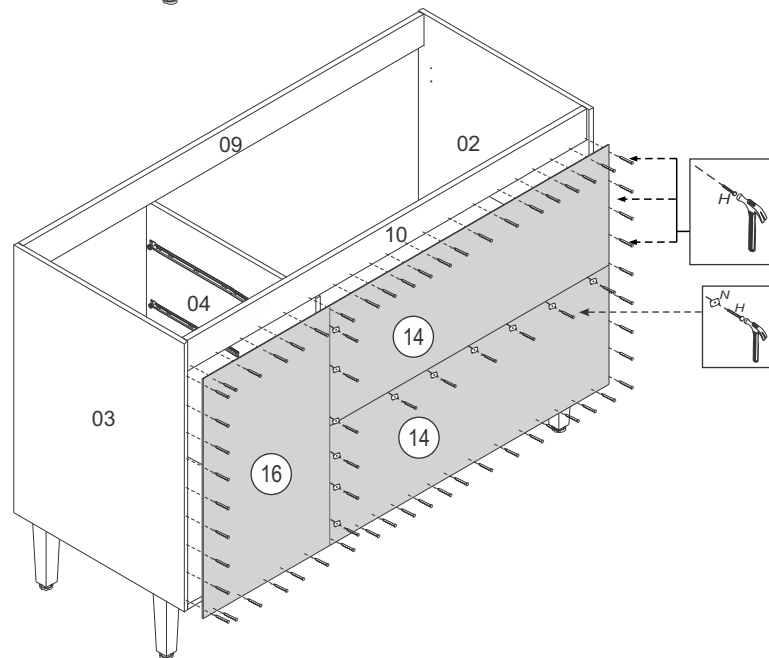

7º Passo
7º Paso
7º Step

Montagem das dobradiças nas portas (12,13) colocando calço e dobradiça.
 Montaje de las bisagras en las puertas (12,13) Poner la base y bisagra.
 The assembly of the Hinge in the door (12,13) putting the base of Hinge and hinge .

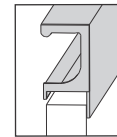
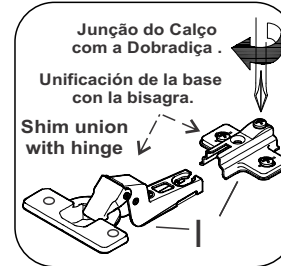

Encaixar Puxador na porta
 Fit the Handle in the door
 Encajar el Tirador en la puerta

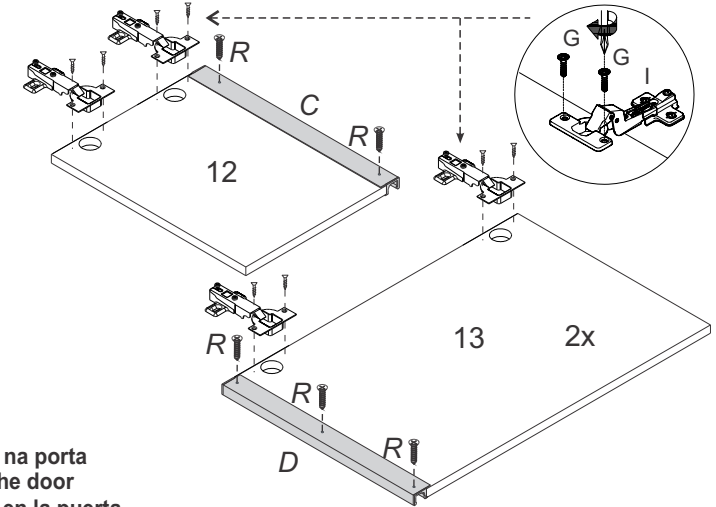

Cuidar lado da colocação do Puxador nas portas (12,13)
 Tenga cuidado con la colocación del tirador la Puertas (12,13)
 When assembly the handle holding caution the side to assembly door (12,13)

8º Passo
8º Paso
8º Step

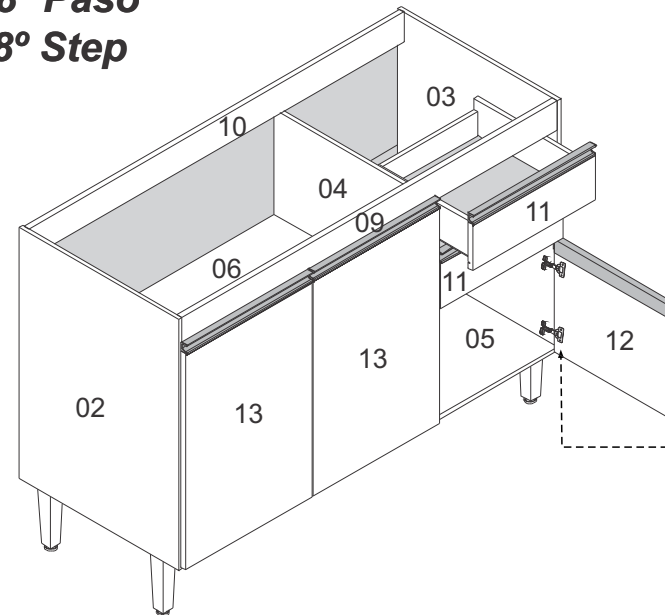

EM TODAS AS PORTAS DA MESMA MANEIRA
 EN TODAS LAS PUERTAS DE LA MISMA MANERA
 ON ALL DOORS THE SAME WAY

REGULAGEM / REGLAJE / ADJUSTMENT

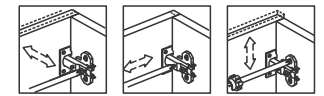

Possuem marcação de fixação das dobradiças nas peças. (01,02,03).

Tienen perforación de fijación de las bisagras en las piezas (01,02,03).

There are markings of hinges assembly in the parts (01,02,03).

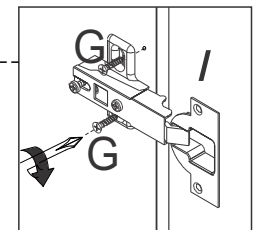

Cozinha/Cocina/Kitchen

ENEZA

BC-4200

DIMENSÕES PEÇAS PRONTAS
DIMENSIONES DE LAS PEZAS PRONTAS
DIMENSIONS READY MODE PARTS

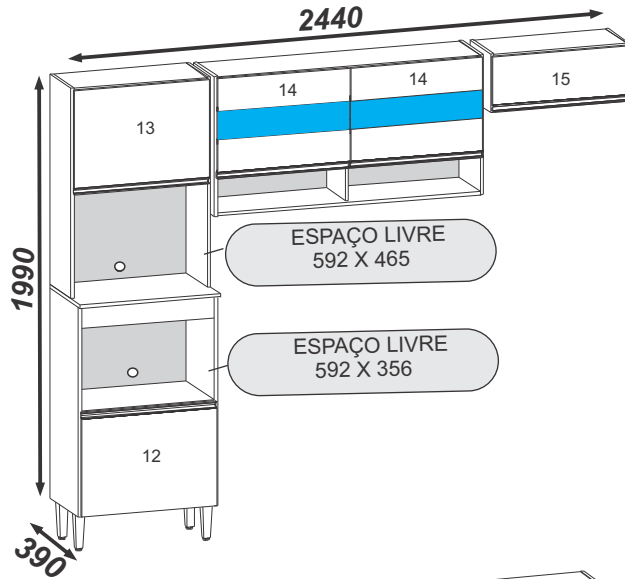

- 01-Lateral Esquerda Paneleiro
- 02-Lateral Direita Paneleiro
- 03-Lateral Esquerda Forno
- 04-Lateral Direita Forno
- 05-Tampo Forno
- 06-Travessa Inferior
- 07-Lateral Esq. Aereo Pia
- 08-Lateral Direita Aereo Pia
- 09-Divisao Aero Pia
- 10-Tampo Inferior Aereo Pia
- 11-Pilaster
- 12-Porta Paneleiro Inferior
- 13-Porta Paneleiro Superior
- 14-Porta Aereo Pia (2x)
- 15-Porta Aereo Menor
- 16-Tampo Inferior Paneleiro
- 17-Prateleira Paneleiro
- 18-Prateleira Superior Paneleiro (2x)
- 19-Tampo Superior Aereo Pia
- 20-Prateleira Central Aereo Pia
- 21-Lateral Aereo Menor (2x)
- 22-Tampo Aereo Menor (2x)
- 23-Costa Paneleiro Inferior
- 24-Costa Furada Forno Inferior
- 25-Costa Furada Forno Superior
- 26-Costa Superior Forno
- 27-Costa Aereo Pia Superior
- 28-Costa Aereo Pia Inferior
- 29-Costa Aereo Menor

- 01-Lateral Izquierda Paneleiro
- 02-Lateral Derecha Paneleiro
- 03-Lateral Izquierda horno
- 04-Lateral Derecha horno
- 05-Tapa del Horno
- 06-Travesaño Inferior
- 07-Lateral Izquierda fregadero de arriba
- 08-Lateral Derecha fregadero de arriba
- 09-Division fregadero de arriba
- 10-Tapa Inferior fregadero de arriba
- 11-Pilaster
- 12-Puerta Paneleiro Inferior
- 13-Puerta Paneleiro Superior
- 14-Puerta fregadero de arriba (2x)
- 15-Puerta Aéreo Menor
- 16-Tapa Inferior Paneleiro
- 17-Estante Paneleiro
- 18-Estante Superior Paneleiro (2x)
- 19-Tapa Superior fregadero de arriba
- 20-Estante Central Aéreo Pia
- 21-Lateral Aereo Menor (2x)
- 22-Tapa Aereo Menor (2x)
- 23-Dorso Paneleiro Inferior
- 24-Dorso Perforado Horno Inferior
- 25-Dorso Perforado Horno Superior
- 26-Dorso Superior Horno
- 27-Dorso fregadero de arriba Superior
- 28-Dorso fregadero de arriba Inferior
- 29-Dorso Aéreo Menor

- 01-Left Side Fag
- 02-Right Side Fag
- 03-Left Side Oven
- 04-Right Side Oven
- 05-Oven Top
- 06-Lower Crossbar
- 07-Left Side Air Sink
- 08-Right Side Air Sink
- 09-Divider Air Sink
- 10-Lower Top Air Sink
- 11-Pilaster
- 12-Door Lower Fag
- 13-Door upper Fag
- 14-Door Air Sink (2x)
- 15-Door small Air sink
- 16-Lower Top Fag
- 17-Shelf Fag
- 18-Upper Shelf Fag (2x)
- 19-Upper Top Air Sink
- 20-Central Shelf Air Sink
- 21-Smal Side Air Sink (2x)
- 22-Smal Top Air Sink (2x)
- 23-Lower Back Panel Fag
- 24-Lower Back Panel Bored Oven
- 25-Upper Back Panel Bored Oven
- 26-Upper Back panel Oven
- 27-Upper Back Panel Air Sink
- 28-Lower Back Panel Air Sink
- 29-Smal Back Panel Air Sink

- 01-909 X 360 X 15
- 02-909 X 360 X 15
- 03-909 X 268 X 15
- 04-909 X 268 X 15
- 05-625 X 386 X 15
- 06-592 X 95 X 15
- 07-605 X 268 X 15
- 08-605 X 268 X 15
- 09-145 X 244 X 15
- 10-1170 X 267 X 15
- 11-419 X 95 X 15
- 12-603 X 423 X 15
- 13-603 X 406 X 15
- 14-587 X 406 X 15
- 15-603 X 214 X 15
- 16-592 X 359 X 12
- 17-592 X 359 X 12
- 18-592 X 267 X 12
- 19-1170 X 267 X 12
- 20-1170 X 267 X 12
- 21-254 X 268 X 12
- 22-592 X 267 X 12
- 23-608 X 448 X 3
- 24-608 X 464 X 3
- 25-608 X 479 X 3
- 26-608 X 432 X 3
- 27-1190 X 432 X 3
- 28-1190 X 160 X 3
- 29-608 X 243 X 3

Instruções para a montagem do produto: Product assembly instructions: Instrucciones de montaje del Producto:

Separe as peças e acessórios de maneira organizada.
Separate the parts and accessories in an organized way.
Separe las piezas y accesorios de forma organizada

Forrar o chão com o papelão das embalagens.
Cover the floor with the cardboard from the pack.
Cubre el suelo con el cartón de los bultos.

É necessário duas pessoas para montar o produto.
It's necessary two people to assembly the product.
Se requiere dos personas para montar el producto.

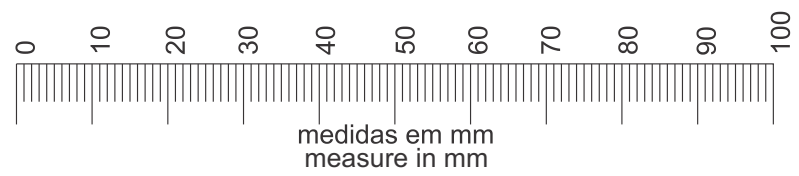

Ferragens/Herraje/Hardware:

330	A	Cavilhas 6 x 30 Clavija Wood Peg		50
0289	B	Parafuso 3,5 x 40 Tornillo Screw		46
-----	C	Puxador VP25 com tampa 603mm Tirador Handle		03
-----	D	Puxador VP25 com tampa 587mm Tirador Handle		02
0477	E	Cola Pegamento Glue		01
5159	F	Cavilhas 6 x 50 Clavija Bowel		01
0290	G	Parafuso 3,5 x 14 c/c Tornillo Screw		50
0296	H	Chave 10 x 7 Clavo 10 x 7 Nail 10 x 7		110
151	I	Dobradiça metal Bisagra Hinge		10
0538	J	Porca cilíndrica Tuerca Cilíndrica Cylindrical nut		32
0438	K	Cantoneira Esquina Cantoneira		05
-----	L	Pés Pies Feet		04
0555	M	Parafuso 5 X 50 Tornillo Screw		04
0279	N	Fixador De Costa Fixador de Espalda Fix Back		19
3125	O	Kit Fixação Parede Kit Fijación del Pared Wall Mounting Kit 5 Cantoneira, 5 Colça, 5 Parafuso, 5 Bucha		01
0293	P	Parafuso 3,5 x 14 CF Tornillo Screw		15

Ferramentas necessárias (não fornecidas) Herrajes necesarias (no incluye) Necessary tools (not supplied)

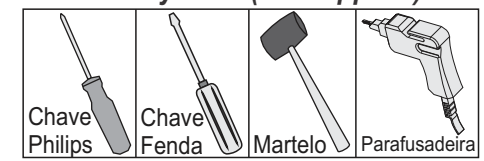

01° Passo
01° Paso
01° Step

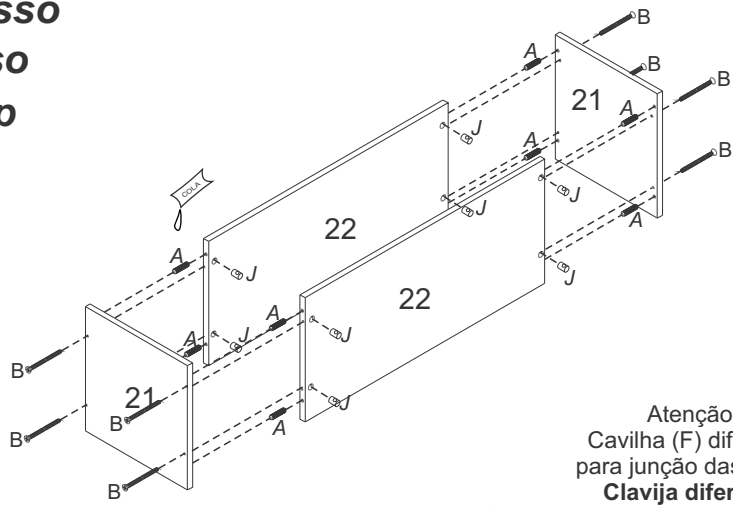

02° Passo
02° Paso
02° Step

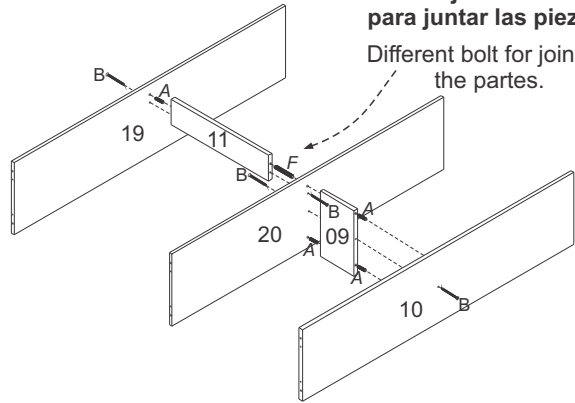

Atenção!
 Cavilha (F) diferente
 para junção das peças
Clavija diferente
 para juntar las piezas
 Different bolt for joining
 the partes.

03° Passo
03° Paso
03° Step

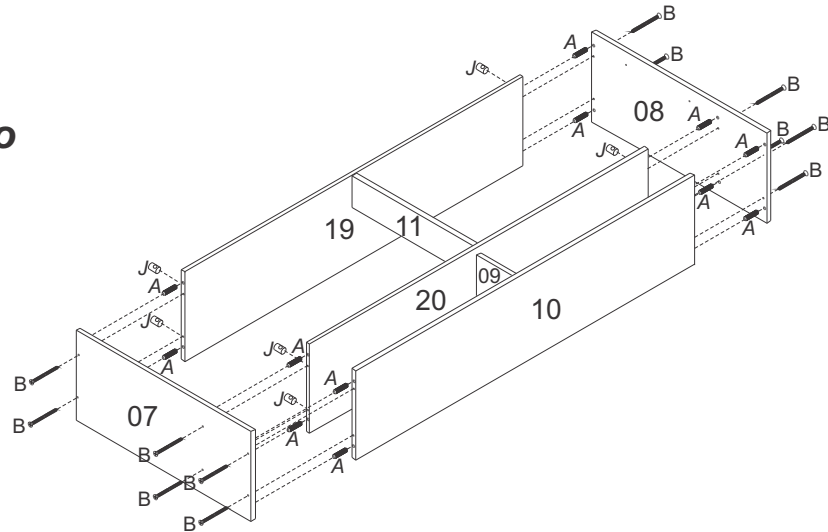

04° Passo
04° Paso
04° Step

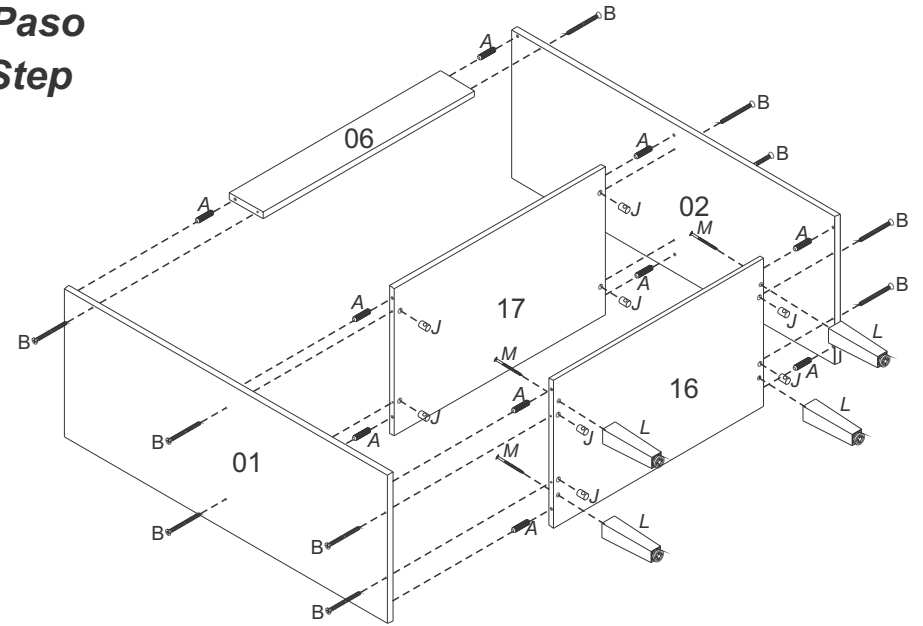

05° Passo
05° Paso
05° Step

