

Cooktop/Anafe/Cooktop

MADRI

BC-4105

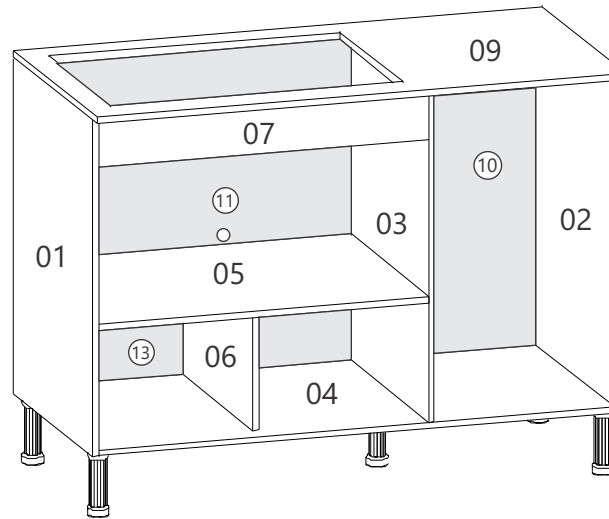
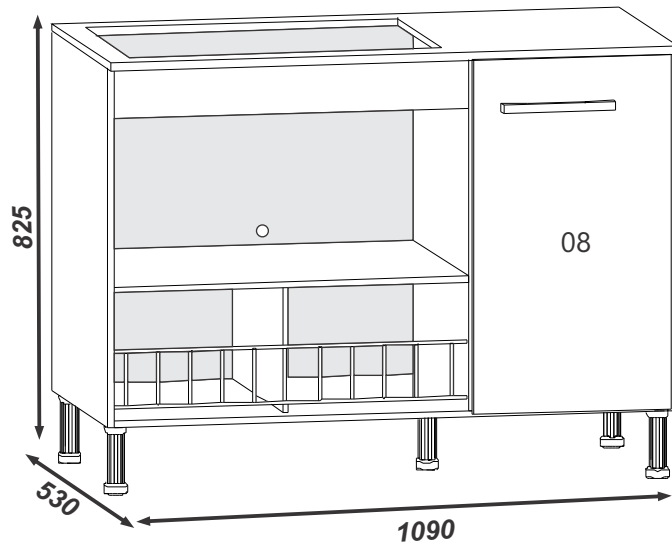

POI

- 1-Lateral Esquerda
- 2-Lateral Direita
- 3-Divisória
- 4-Tampo Inferior
- 5-Prateleira
- 6-Divisória Esquerda
- 7-Travessa Frontal
- 8-Porta
- 9-Tampo Superior
- 10-Costa Direita
- 11-Costa Furada
- 13-Costa Inferior

ENG

- 1-Left Side
- 2-Right Side
- 3-Divider
- 4-Lower Top
- 5-Shelf
- 6-Left Divider
- 7-Front Crossbar
- 8-Door
- 9-Upper Top
- 10-Right Back Panel
- 11-Bored Back Panel
- 13-Lower Back Panel

ESQ

- 1-Lateral Izquierda
- 2-Lateral Derecha
- 3-Division
- 4-Tapa Inferior
- 5-Estante
- 6-Division Izquierda
- 7-Travessaño Frontal
- 8-Puerta
- 9-Tapa Superior
- 10-Dorso Derecha
- 11-Dorso Furada
- 13-Dorso Inferior

DIMENSÕES PEÇAS PRONTAS
DIMENSIONES DE LAS PEZAS PRONTAS
DIMENSIONS READY MODE PARTS

- 01-680 X 500 X 12
- 02-680 X 500 X 12
- 03-668 X 498 X 12
- 04-1062 X 499 X 12
- 05-680 X 497 X 12
- 06-242 X 450 X 12
- 07-680 X 95 X 15
- 08-671 X 380 X 15
- 09-1088 X 530 X 15
- 10-686 X 385 X 3
- 11-695 X 430 X 3
- 13-695 X 256 X 3

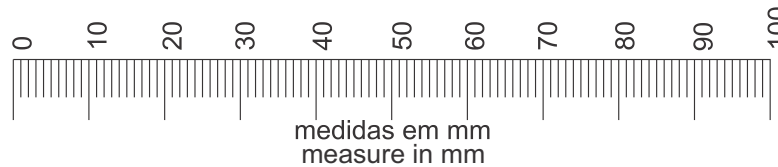

Instruções para a montagem do produto:

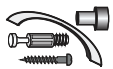

Separe as peças e acessórios de maneira organizada.
 Separate the parts and accessories in an organized way.
 Separe las piezas y accesorios de forma organizada



É necessário duas pessoas para montar o produto.
 It's necessary two people to assembly the product.
 Se requiere dos personas para montar el producto.

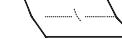

Forrar o chão com o papelão das embalagens.
 Cover the floor with the cardboard from the pack.
 Cubre el suelo con el cartón de los bultos.

Ferragens/Herraje/Hardware:

330	A	Cavilhas 6 x 30 Clavija 6 x 30 Wood Peg		22
0289	B	Parafuso 3,5 x 40 Tornillo Screw		14
-----	C	Puxador 192 mm CROMADO Tirador Handle		01
0285	D	Parafuso 3,5 x 25 flangeado Tornillo Screw		02
0477	E	Cola Pegamento Glue		01
0283	G	Parafuso 3,5 x 12 c/c Tornillo Screw		24
0296	H	Taxa 10 x 7 Clavo 10 x 7 Nail 10 x 7		60
151	I	Dobradiça metal Bisagra Hinge		02
0538	J	Porca cilíndrica Tuerca cilíndrica Cylindrical nut		08
0438	K	Cantoneira Esquinera Cantoneira		08
-----	L	Pés Pies Feet		05
2819	M	Parafuso 7 x 40 Tornillo Screw		05
0279	N	Fixador De Costa Fixador de Espalda Fix Back		10
0973	O	Tambor minifix 12 mm Minifix 12 mm Minifix 12 mm		02
0115	P	Parafuso minifix Tornillo Screw		02
7692	Q	Grade 690 mm Grade 690 mm Grid 690 mm		01

Ferramentas necessárias (não fornecidas)

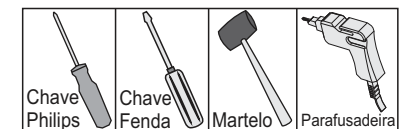

01° Passo
01° Paso
01° Step

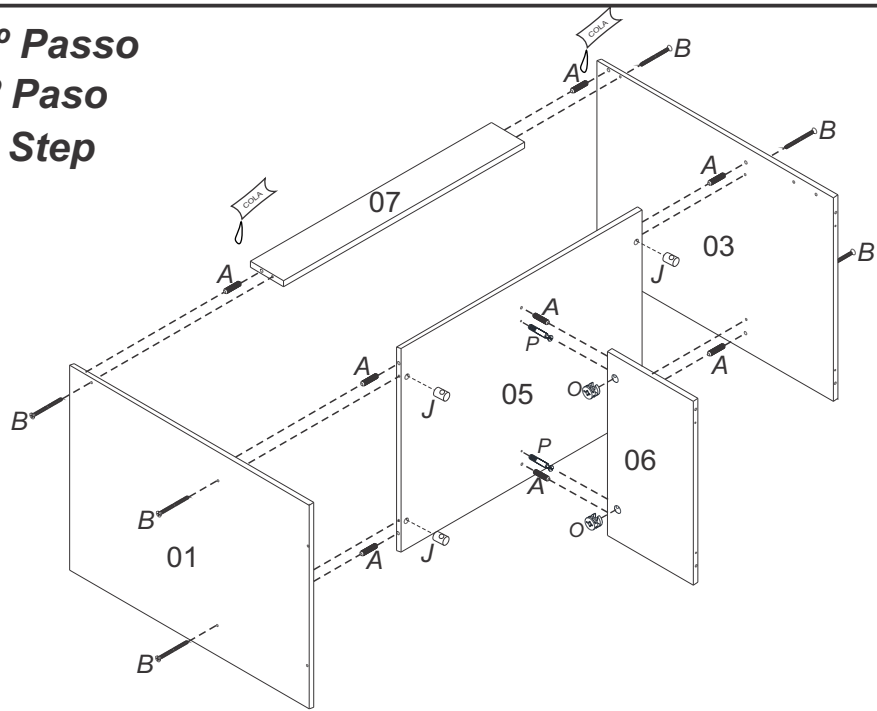

02° Passo
02° Paso
02° Step

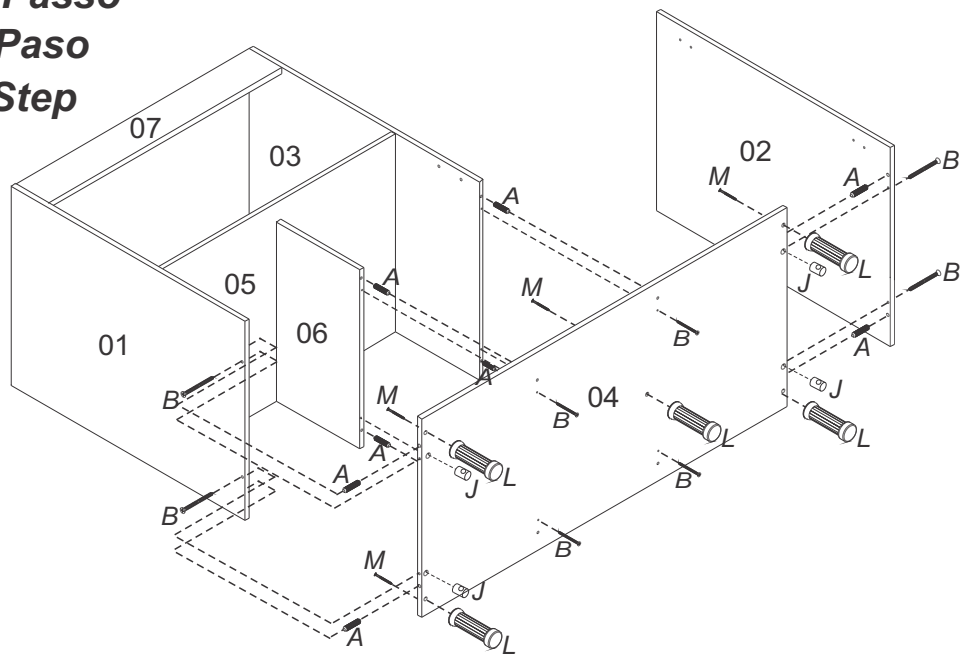

03° Passo
03° Paso
03° Step

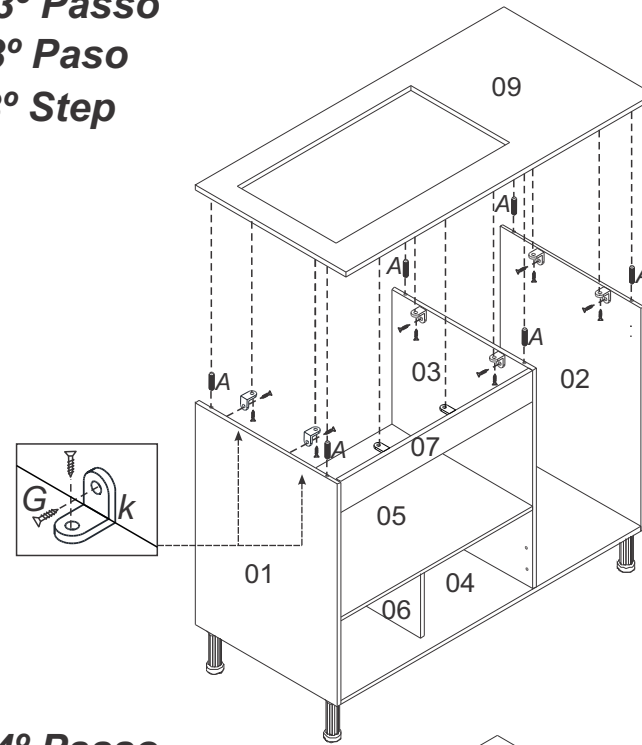

04° Passo
04° Paso
04° Step

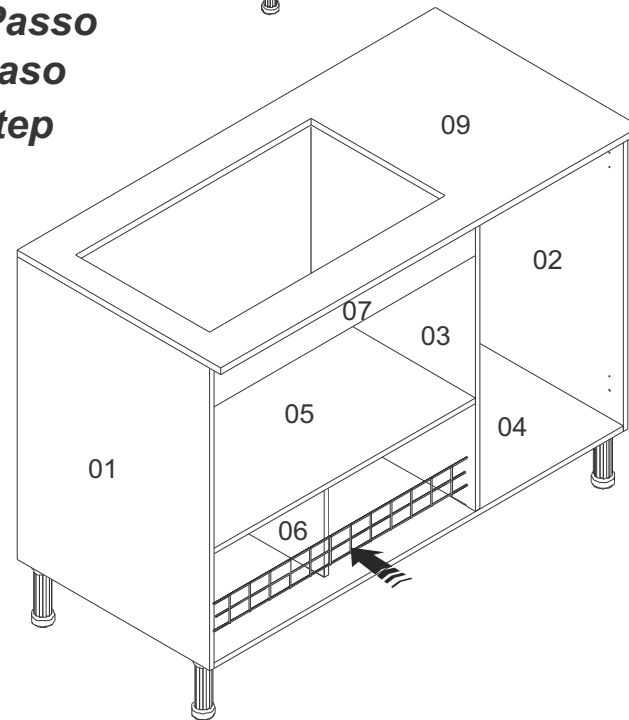

05° Passo

05° Paso

05° Step

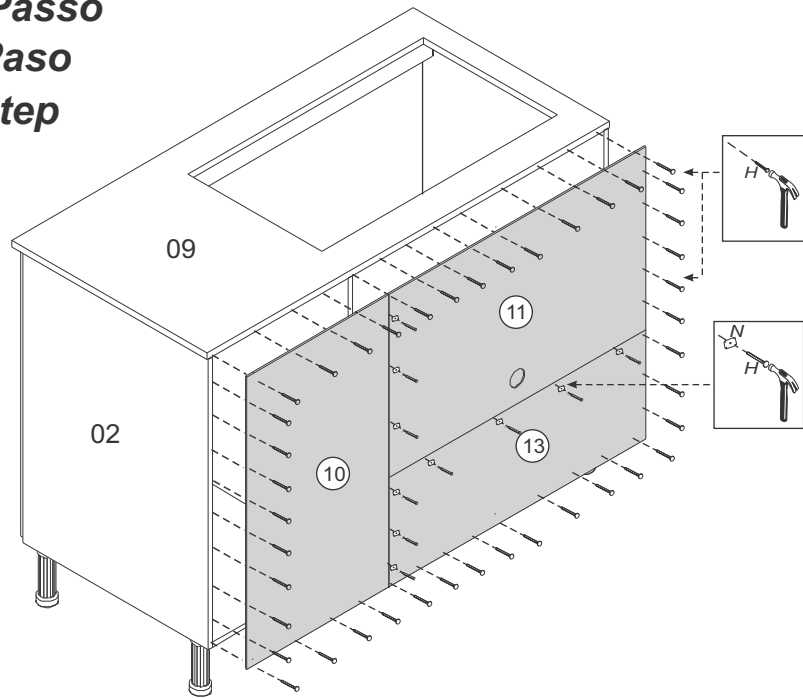

06° Passo

06° Paso

06° Step

Montagem das dobradiças nas portas (09) colocando calço e dobradiça.
Montaje de las bisagras en las puertas (09) Poner la base y bisagra.
The assembly of the Hinge in the door (09) putting the base of Hinge and hinge .

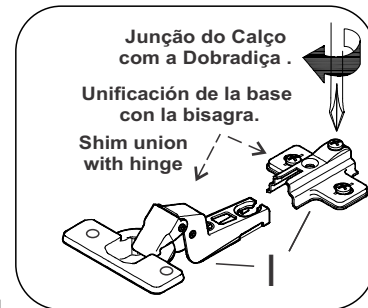
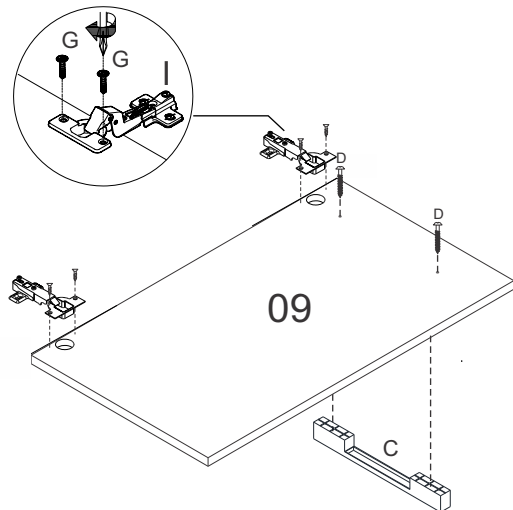

07° Passo

07° Paso

07° Step

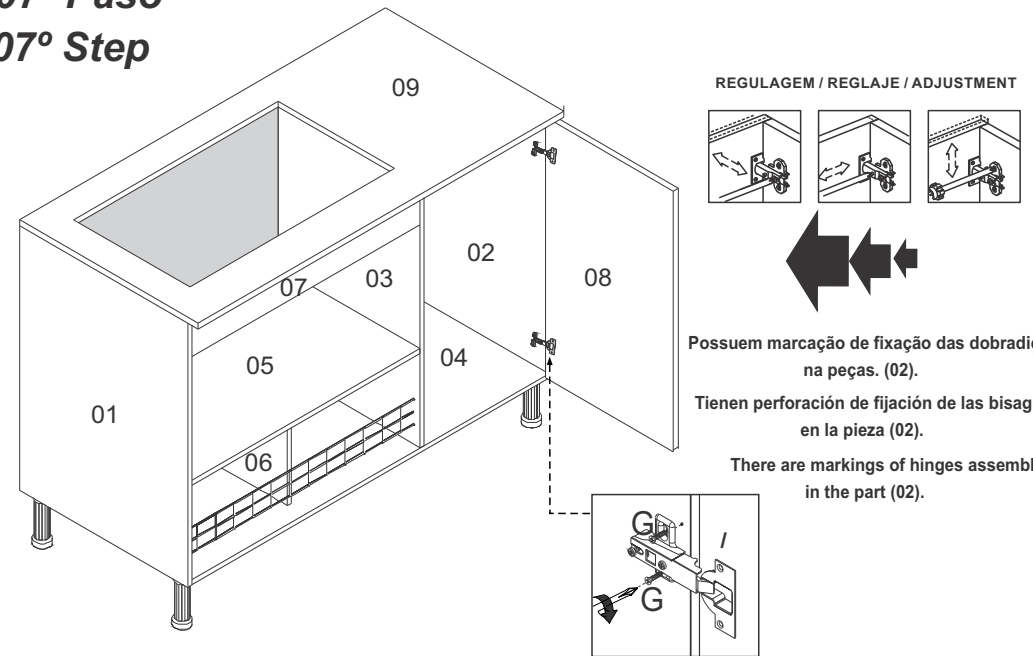

08° Passo

08° Paso

08° Step

