

Cozinha/Cocina/Kitchen NAPOLES BC-4340

MANUAL DE MONTAGEM
INSTRUCCIONES DE ARMADO
ASSEMBLY INSTRUCTIONS

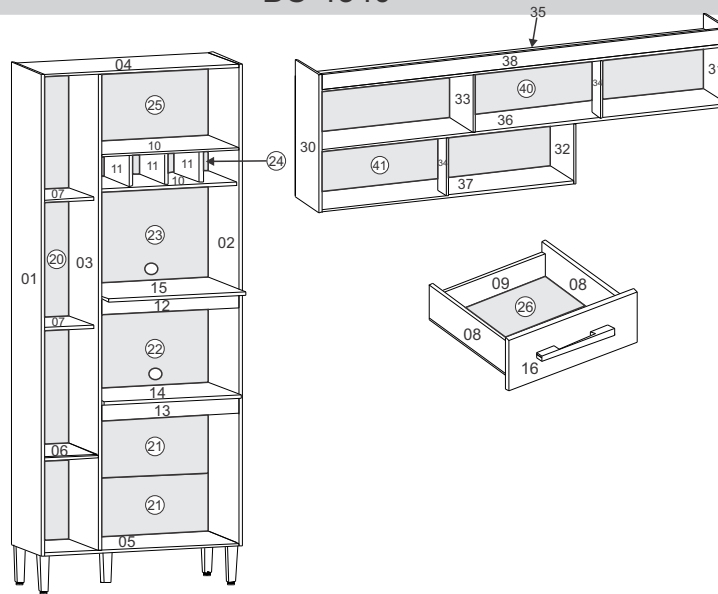
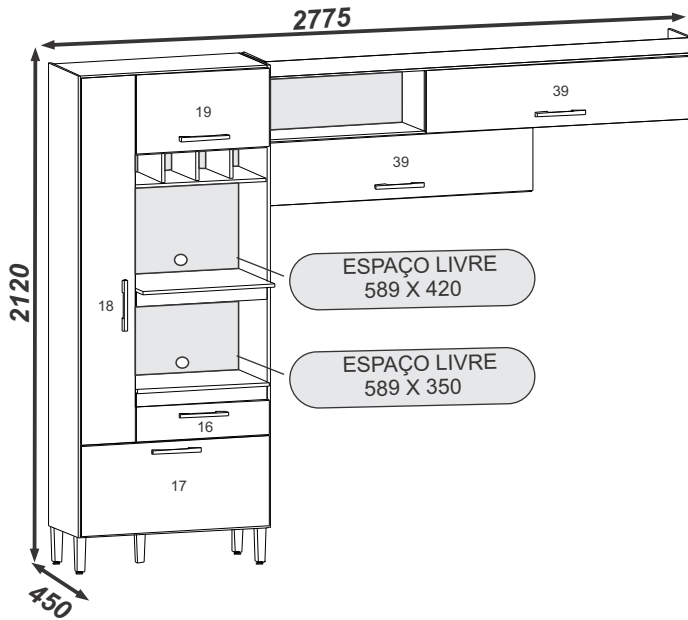

01-LATERAL ESQUERDA
02-LATERAL DIREITA
03-DIVISÓRIA
04-TAMPO SUPERIOR
05-TAMPO INFERIOR
06-TAMPO INFERIOR ESQUERDO
07-PRATELEIRA ESQUERDA (2x)
08-LATERAL DE GAVETA (2x)
09-TRASEIRO DE GAVETA
10-TAMPO SUPERIOR DIREITO (2x)
11-TRAVESSA GARRAFA (3x)
12-TRAVESSA TAMPO FORNO
13-TRAVESSA TAMPO MICRO
14-TAMPO MICRO
15-TAMPO FORNO
16-FRENTE DE GAVETA
17-PORTA INFERIOR
18-PORTA ESQUERDA
19-PORTA SUPERIOR
20-COSTA ESQUERDA
21-COSTA INFERIOR (2x)
22-COSTA MICRO
23-COSTA FORNO
24-COSTA GARRAFA
25-COSTA SUPERIOR
26-FUNDO DE GAVETA
30-LATERAL AEREO ESQUERDA
31-LATERAL AEREO SUPERIOR DIREITA
32-LATERAL AEREO INFERIOR DIREITA
33-DIVISÓRIA AEREO
34-PILASTRA AEREO (2x)
35-TAMPO SUPERIOR AEREO
36-TAMPO CENTRAL AEREO
37-TAMPO INFERIOR AEREO
38-FRONTAL
39-PORTA (2x)
40-COSTA SUPERIOR AEREO
41-COSTA INFERIOR AEREO

01-LATERAL IZQUIERDA
02-LATERAL DERECHA
03-DIVISION
04-TAPA SUPERIOR
05-TAPA INFERIOR
06-TAPA INFERIOR IZQUIERDO
07-ESTANTE IZQUIERDA (2x)
08-LATERAL DEL CAJÓN (2x)
09-TRASERO DEL CAJÓN
10-TAPA SUPERIOR DERECHA (2x)
11-TRAVESAÑO BOTELLA (3x)
12-TRAVESAÑO TAPA HORNO
13-TRAVESAÑO TAPA MICRO
14-TAPA MICRO
15-TAPA HORNO
16-FRENTE DEL CAJÓN
17-PUERTA INFERIOR
18-PUERTA IZQUIERDA
19-PUERTA SUPERIOR
20-DORSO IZQUIERDA
21-DORSO INFERIOR (2x)
22-DORSO MICRO
23-DORSO HORNO
24-DORSO BOTELLA
25-UPPER BACK PANEL
26-FUNDO DEL CAJÓN
30-LATERAL AEREO IZQUIERDA
31-LATERAL AEREO SUPERIOR DERECHA
32-LATERAL AEREO INFERIOR DERECHA
33-DIVISION AEREO
34-PILASTER AEREO (2x)
35-TAPA SUPERIOR AEREO
36-TAPA CENTRAL AEREO
37-TAPA INFERIOR AEREO
38-FRONTAL
39-PUERTA (2x)
40-DORSO SUPERIOR AEREO
41-DORSO INFERIOR AEREO

01-LEFT SIDE
02-RIGHT SIDE
03-DIVIDER
04-UPPER TOP
05-LOWER TOP
06-LEFT LOWER TOP
07-LEFT SHELF (2x)
08-DRAWER SIDE (2x)
09-DRAWER BACK
10-RIGHT UPPER TOP (2x)
11-BOTTLE CROSSBAR (3x)
12-OVEN TOP CROSSBAR
13-MICRO TOP CROSSBAR
14-MICRO TOP
15-OVEN TOP
16-DRAWER FRONT
17-LOWER DOOR
18-LEFT DOOR
19-UPPER DOOR
20-LEFT BACK PANEL
21-LOWER BACK PANEL(2x)
22-MICRO BACK PANEL
23-OVEN BACK PANEL
24-BOTTLE BACK PANEL
25-UPPER BACK PANEL
26-DRAWER BOTTOM
30-LEFT SIDE AIR
31-AIR RIGHT UPPER SIDE
32-AIR LEFT LOWER SIDE
33-DIVIDER AIR
34-PILASTER AIR (2x)
35-UPPER TOP AIR
36-AIR CENTRAL TOP
37-AIR LOWER TOP
38-FRONT
39-DOOR(2x)
40-AIR UPPER BACK PANEL
41-AIR LOWER BACK PANEL

DIMENSÕES PEÇAS PRONTAS
DIMENSIONES DE LAS PEZAS PRONTAS
DIMENSIONS READY MADE PARTS

01-1961 X 360 X 12
02-1961 X 360 X 12
03-1936 X 359 X 12
04-834 X 359 X 12
05-834 X 359 X 12
06-233 X 359 X 12
07-233 X 299 X 12
08-338 X 95 X 12
09-541 X 65 X 12
10-589 X 359 X 15
11-131 X 299 X 15
12-589 X 65 X 15
13-589 X 65 X 15
14-589 X 386 X 15
15-589 X 450 X 15
16-597 X 147 X 15
17-842 X 384 X 15
18-1556 X 241 X 15
19-597 X 335 X 15
20-1947 X 247 X 3
21-605 X 302 X 3
22-605 X 430 X 3
23-605 X 430 X 3
24-605 X 143 X 3
25-605 X 337 X 3
26-563 X 341 X 3
30-606 X 267 X 12
31-342 X 267 X 12
32-264 X 265 X 12
33-252 X 265 X 12
34-252 X 94 X 12
35-1893 X 265 X 12
36-1893 X 265 X 12
37-1176 X 265 X 12
38-1893 X 65 X 12
39-1190 X 260 X 15
40-1913 X 269 X 3
41-1195 X 269 X 3

Ferragens/Herraje/Hardware:

330	A	Cavilhas 6 x 30 Wood Peg		82
0289	B	Parafuso 3,5 x 40 Tornillo Screw		66
-----	C	Puxador 192 mm CROMADO Tirador Handle		06
0285	D	Parafuso 3,5 x 25 flangeado Tornillo Screw		14
0477	E	Cola Pegamento Glue		01
2331	F	Pistão pneumático 50N Pistón Neumático Pneumatic Piston		02
0283	G	Parafuso 3,5 x 12 c/c Tornillo Screw		98
0296	H	Taxa 10 x 7 Clavo 10 x 7 Nail 10 x 7		110
151	I	Dobradiça metal Bisagra Hinge		14
0538	J	Porca cilíndrica Tuerca cilíndrica Cylindrical nut		29
0438	K	Cantoneira Esquinera Cantoneira		13
-----	L	Pés Pies Feet		05
0555	M	Parafuso 5 X 50 Tornillo Screw		05
0279	N	Fixador De Costa Fixador de Espalda Fix Back		31
5372	O	Kit Fixador de Parede Kit Fijación del Pared Wall Mounting Kit		03
1549	P	Articulador Articulador Articulador		02
3049	Q	Corrediça metálica slim 350mm Rieles Slides		01
4738	R	Cantoneira Plástica Refuerzo de plástico Plastic gusset		01
0286	S	Parafuso 3,5 x 22 c/c Tornillo Screw		01
0744	T	Taxa 13 x 15 Clavo 13 x 15 Nail 13 x 15		04
-----	U	Perfil 588 mm Perfil Profile		01

Parafuso 3,5 x 25 c/c opcional para juntar os modulo.
Tornillo 3,5 x 25 c/c opcional para unificar los modulos.
Optional 3,5 x 25 c/c for joining modules.

Montagem da gaveta Armado de los cajones Drawer Assembly

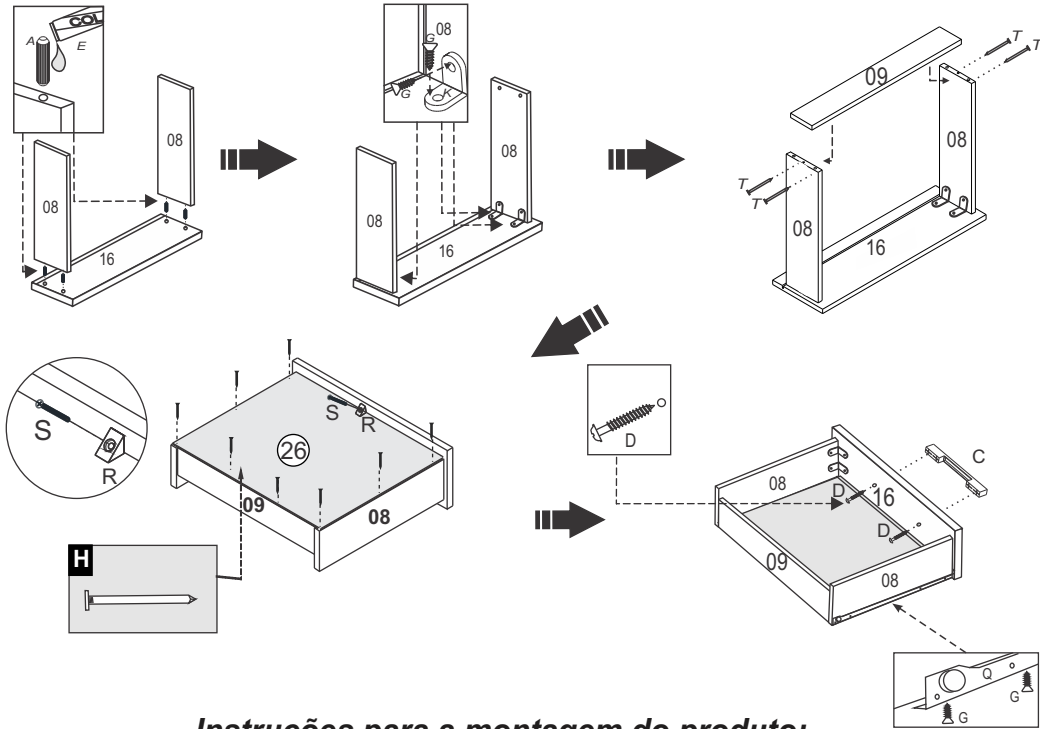

Instruções para a montagem do produto:

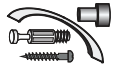

Separe as peças e acessórios de maneira organizada.
Separate the parts and accessories in an organized way.
Separe las piezas y accesorios de forma organizada

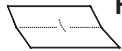

Forrar o chão com o papelão das embalagens.
Cover the floor with the cardboard from the pack.
Cubre el suelo con el cartón de los bultos.



É necessário duas pessoas para montar o produto.
It's necessary two people to assembly the product.
Se requiere dos personas para montar el producto.

Ferramentas necessárias (não fornecidas)

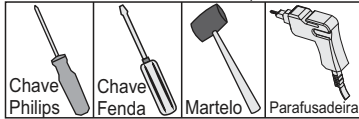

Chave Philips Chave Fenda Martelo Parafusadeira

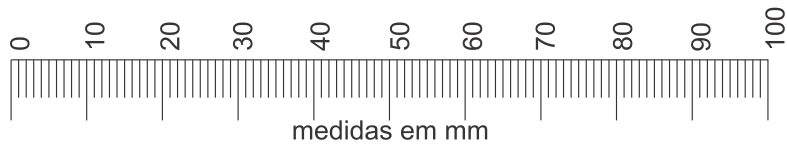

**1º Passo
1º Paso
1º Step**

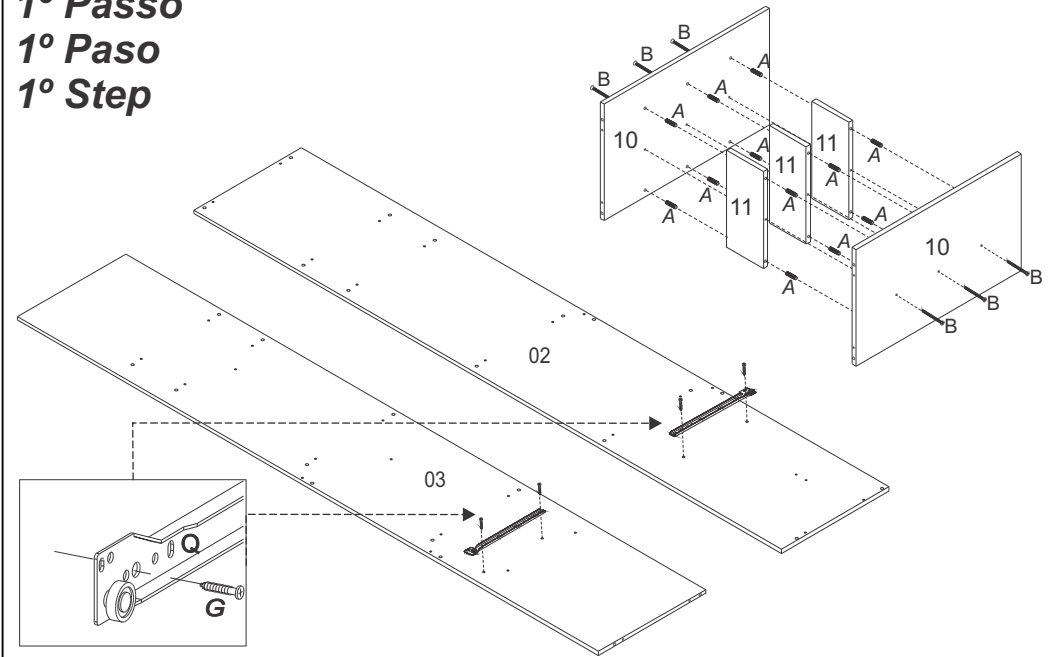

Atenção! ao parafusar a correção ,cuidar o lado certo. **Atención! al atornillar la corredera, cuidar para que esté en el lado correcto** **Attention! When screwing the slide, take care to do the right side**

**2º Passo
2º Paso
2º Step**

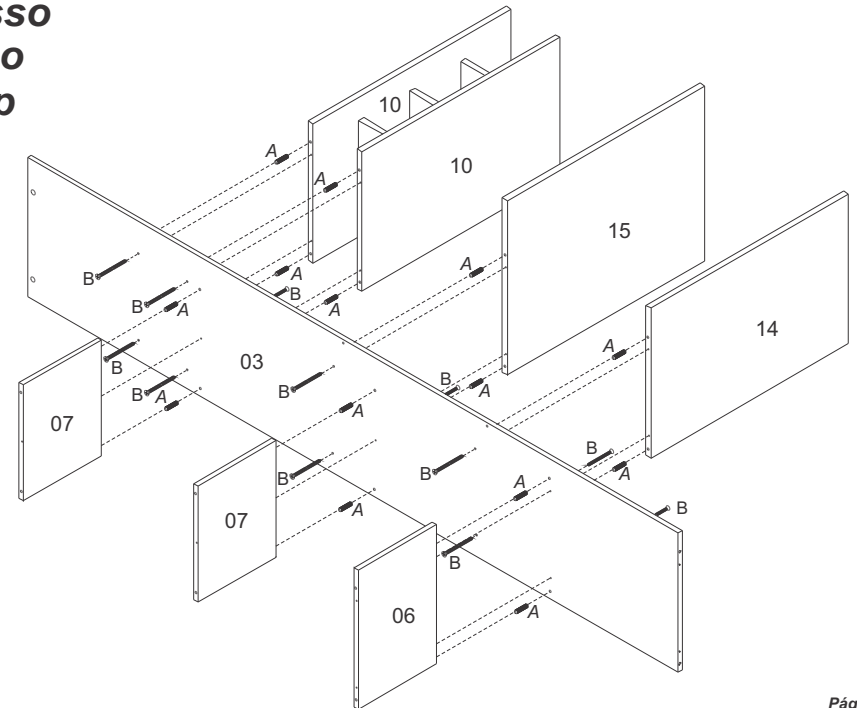

3° Passo

3° Paso

3° Step

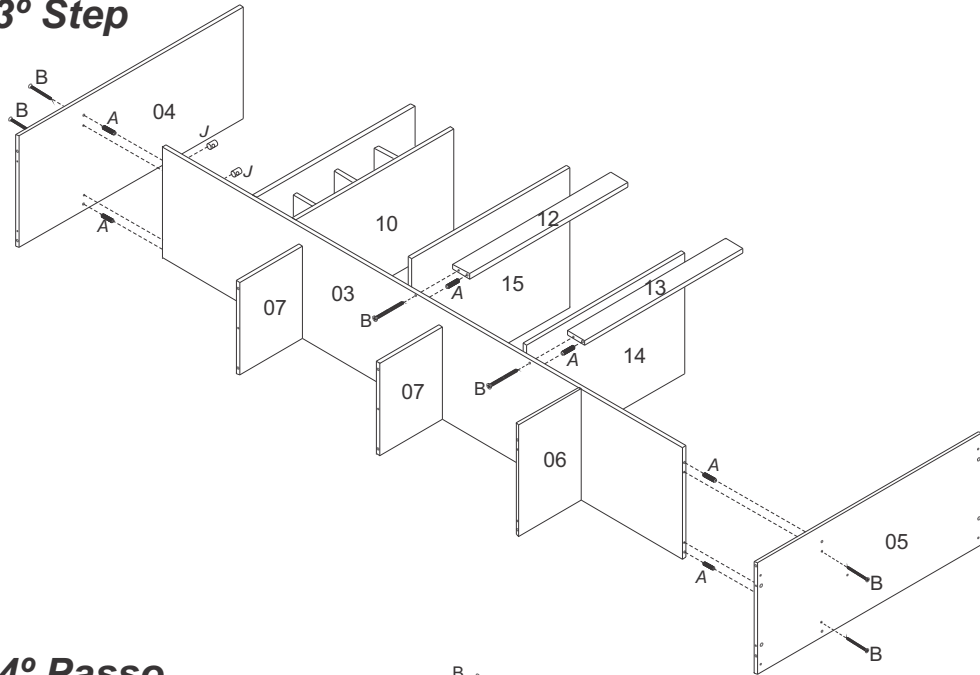

4° Passo

4° Paso

4° Step

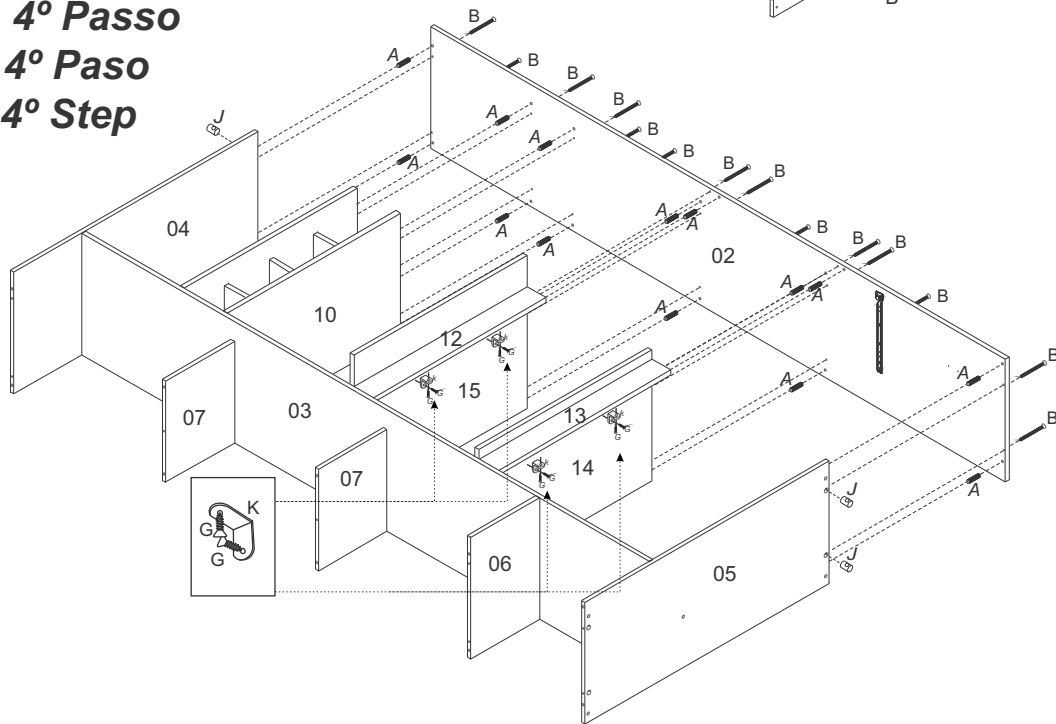

5° Passo

5° Paso

5° Step

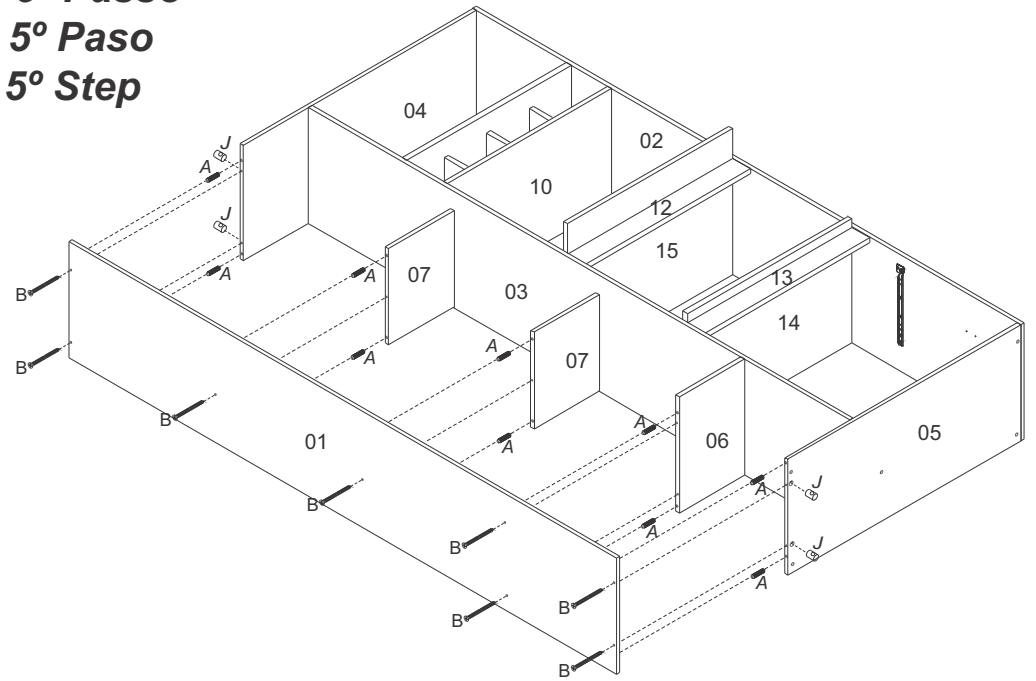

6° Passo

6° Paso

6° Step

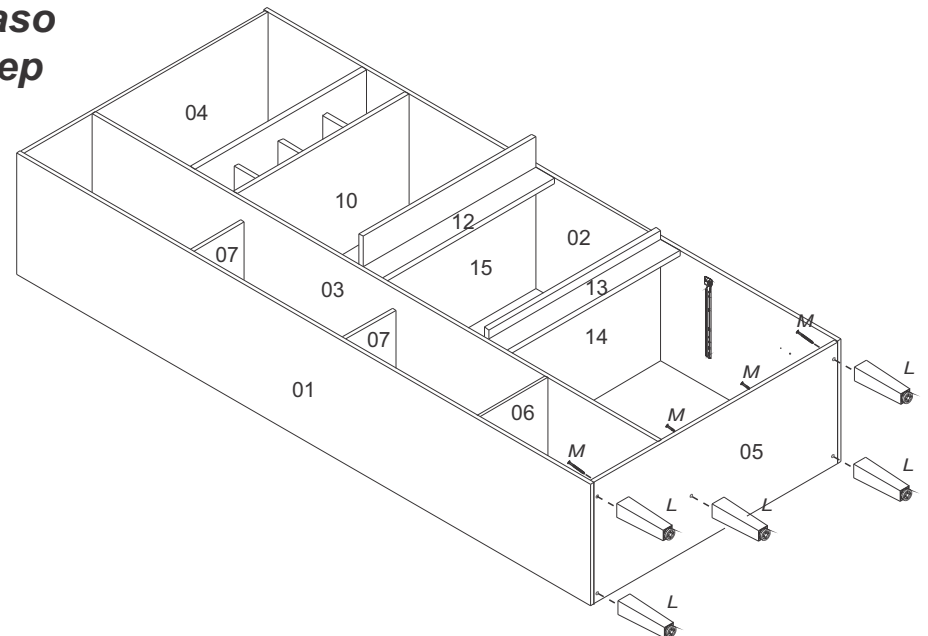

7º Passo
7º Paso
7º Step

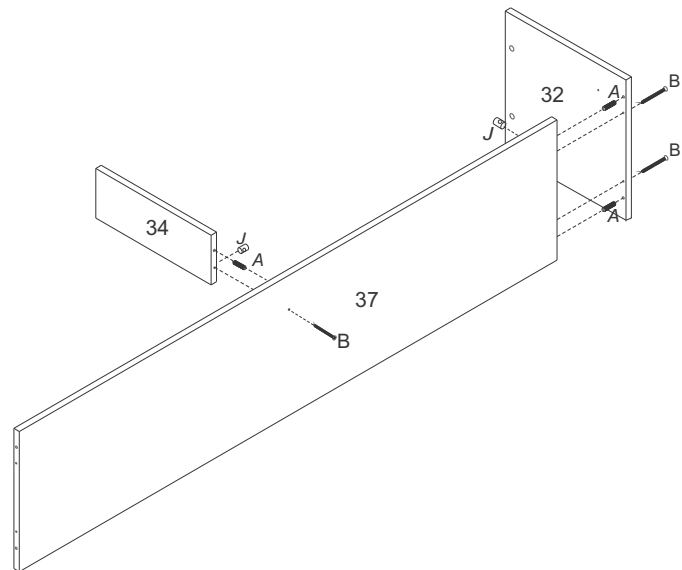

8º Passo
8º Paso
8º Step

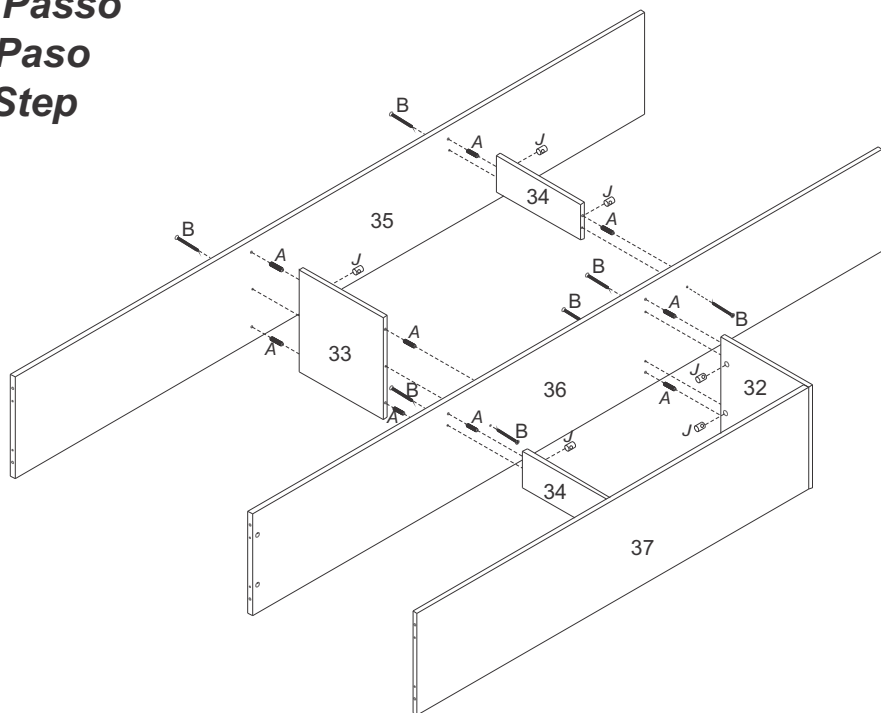

9º Passo
9º Paso
9º Step

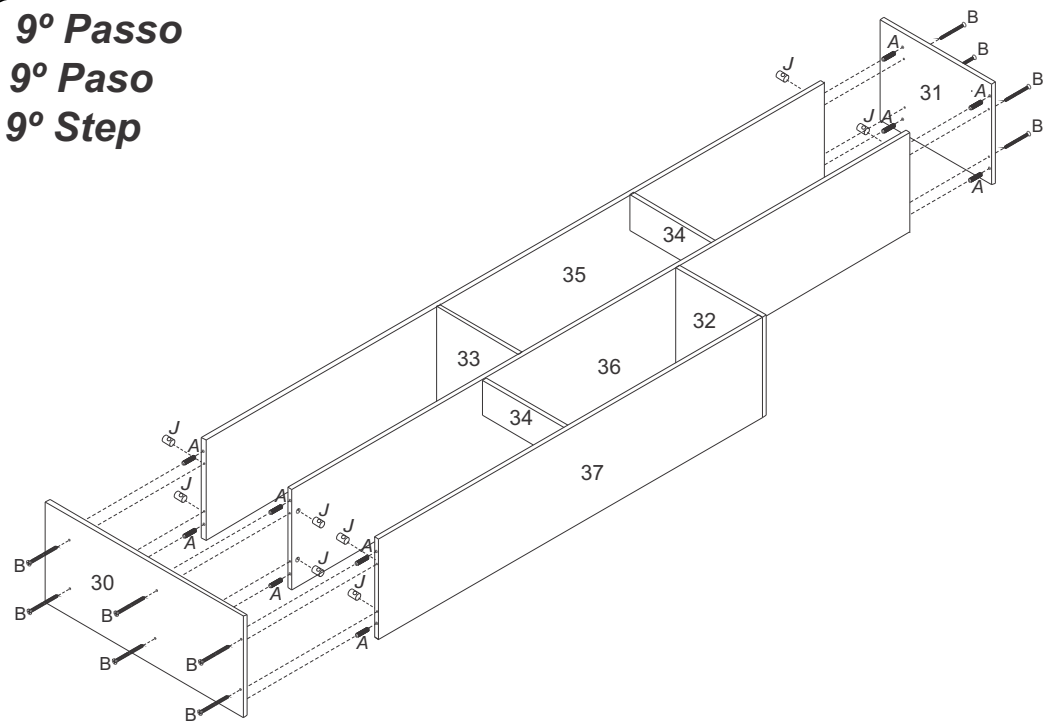

10º Passo
10º Paso
10º Step

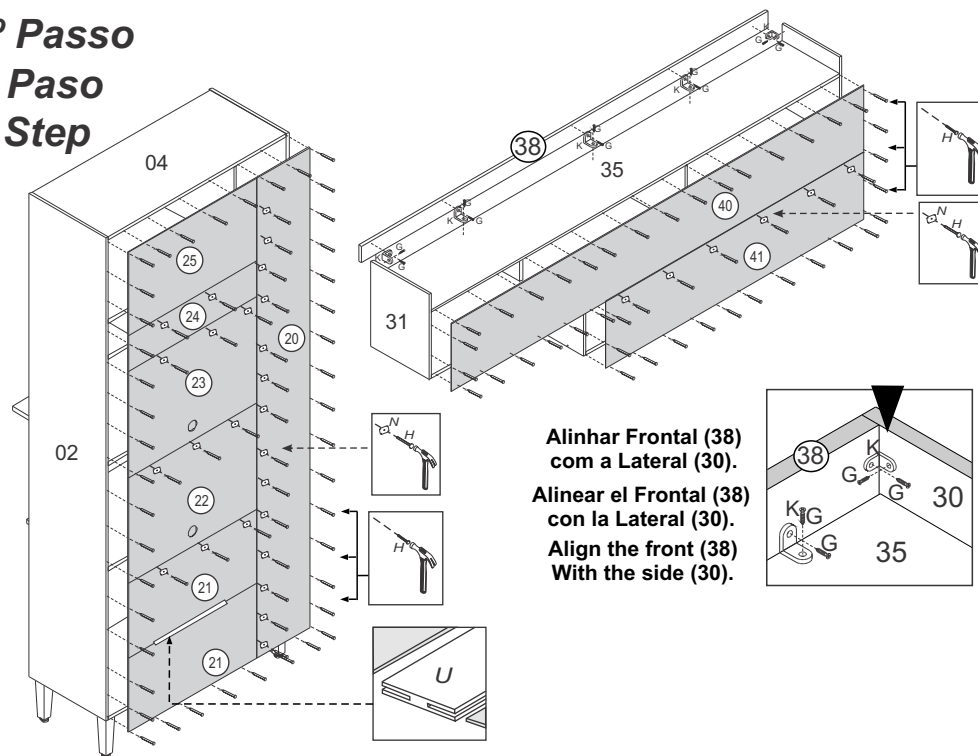

Alinhar Frontal (38)
com a Lateral (30).
Alinear el Frontal (38)
con la Lateral (30).
Align the front (38)
With the side (30).

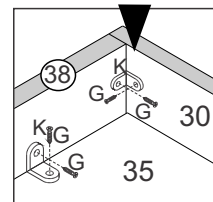

11º Passo

Montagem das dobradiças nas portas (17,18,19,39) colocando calço e dobradiça.

11º Paso

Montaje de las bisagras en las puertas (17,18,19,39) Poner la base y bisagra.

11º Step

The assembly of the Hinge in the door (17,18,19,39) putting the base of Hinge and hinge.

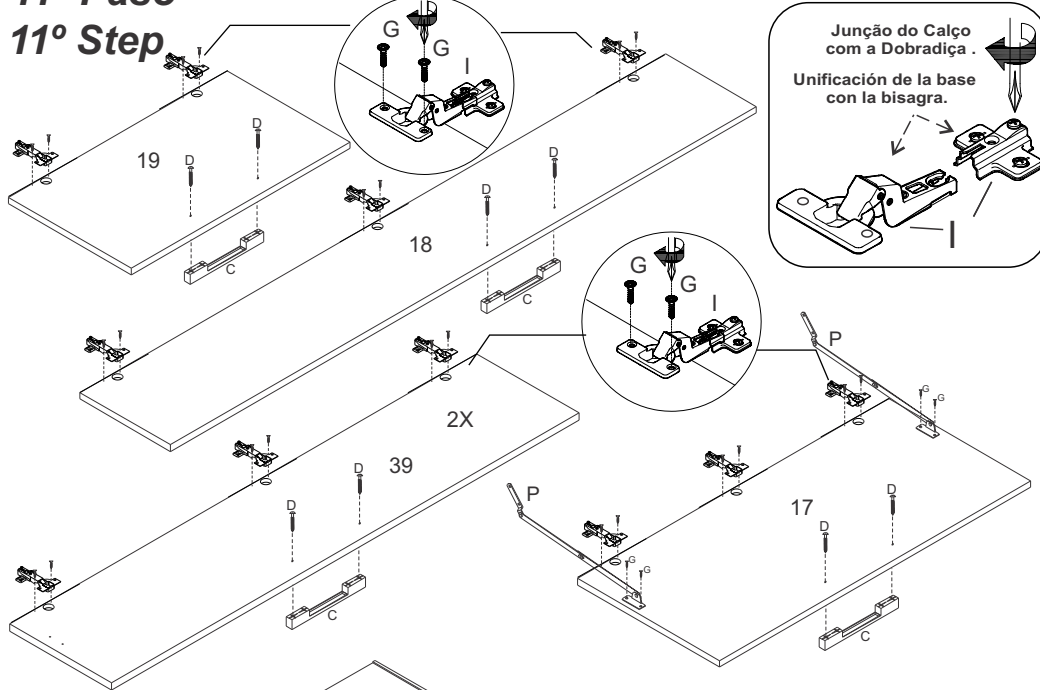

12º Passo

12º Paso

12º Step

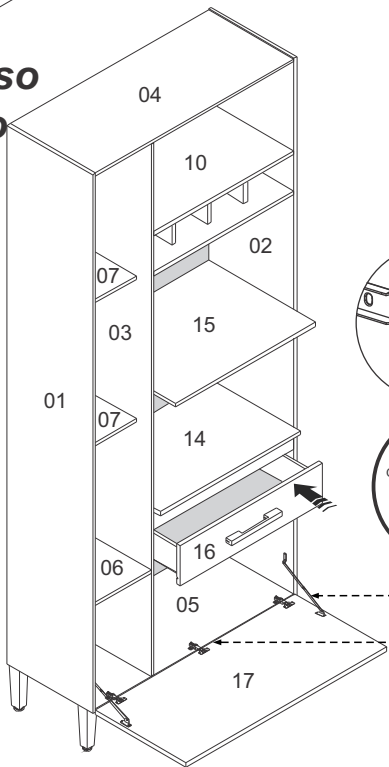

EM TODAS AS PORTAS DA MESMA MANEIRA
EN TODAS LAS PUERTAS DE LA MISMA MANERA
ON ALL DOORS THE SAME WAY

REGULAGEM / REGLAJE / ADJUSTMENT

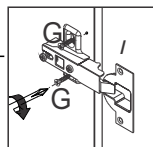
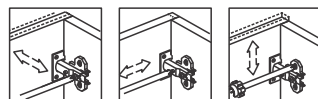

13º Passo

13º Paso

13º Step

EM TODAS AS PORTAS DA MESMA MANEIRA
EN TODAS LAS PUERTAS DE LA MISMA MANERA
ON ALL DOORS THE SAME WAY

REGULAGEM / REGLAJE / ADJUSTMENT

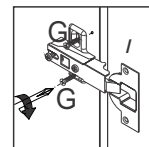
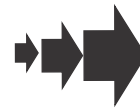
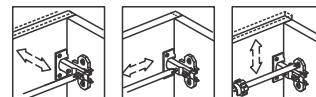

Para uma boa montagem das portas, deixar o Aéreo 100% nivelado.

Para el armado de las puertas, dejar el aereo 100% nivelado.

For a good mounting of the doors, leave the air 100% level.

14º Passo

14º Paso

14º Step

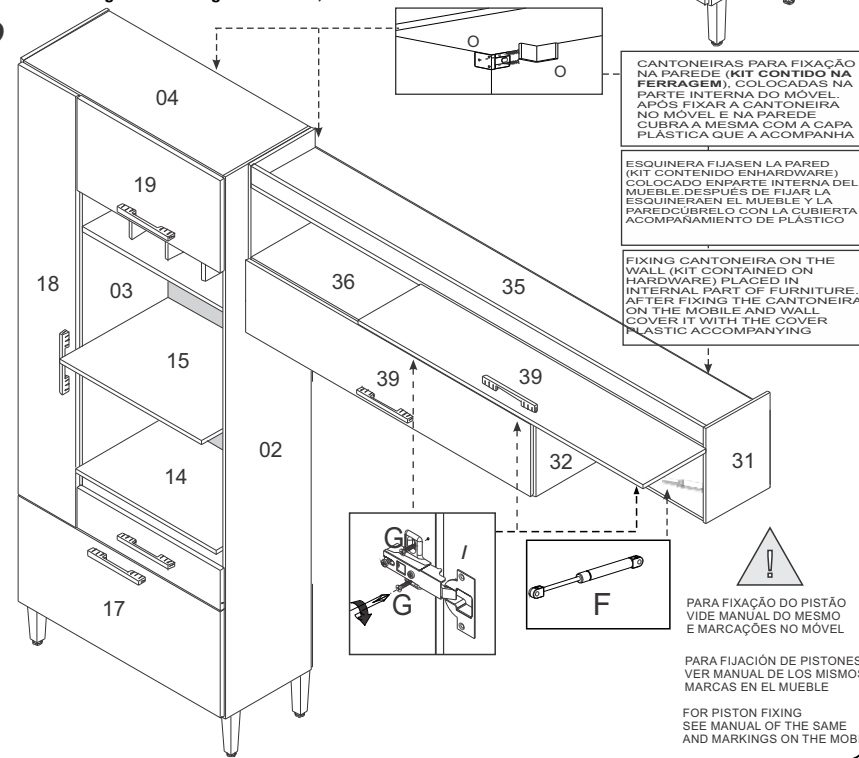

CANTONEIRAS PARA FIXAÇÃO NA PAREDE (KIT CONTIDO NA FERRAGEM). COLOCADAS NA PARTE INTERNA DO MÓVEL. APOS FIXAR A CANTONEIRA NO MÓVEL E NA PAREDE CUBRIR A MESMA COM A CAPA PLÁSTICA QUE A COMPANHA

ESQUINERA FIJASEN LA PARED (KIT CONTENIDO ENHARDWARE) COLOCADO ENPARTE INTERNA DEL MUEBLE DESPUES DE FIJAR LA ESQUINERA EN EL MUEBLE Y LA PAREDCUBRELO CON LA CUBIERTA ACCOMPANIAMIENTO DE PLÁSTICO

FIXING CANTONEIRA ON THE WALL (KIT CONTAINED ON HARDWARE) PLACED IN INTERNAL PART OF FURNITURE. AFTER FIXING THE CANTONEIRA ON THE MOBILE AND WALL COVER IT WITH THE COVER PLASTIC ACCOMPANYING

PARA FIXAÇÃO DO PISTÃO VIDE MANUAL DO MESMO E MARCAÇÕES NO MÓVEL

PARA FIJACIÓN DE PISTONES VER MANUAL DE LOS MISMOS MARCAS EN EL MUEBLE

FOR PISTON FIXING SEE MANUAL OF THE SAME AND MARKINGS ON THE MOBILE

Balcão/Mostrador/Counter

NEVADA

BC-4040

- 01-Lateral Esquerda
- 02-Lateral Direita
- 03-Divisão Esquerda
- 04-Divisão Direita
- 05-Tampo Inferior
- 06-Prateleira
- 07-Lateral de Gaveta (4x)
- 08-Traseiro de Gaveta (2x)
- 09-Travessa Frontal
- 10-Travessa Traseira
- 11-Travessa Toalheiro
- 12-Frente de Gaveta (2x)
- 13-Porta Direita
- 14-Porta (2x)
- 15-Costa Esquerda (2x)
- 16-Costa Direita
- 17-Costra Estreita
- 18-Fundo de Gaveta (2x)

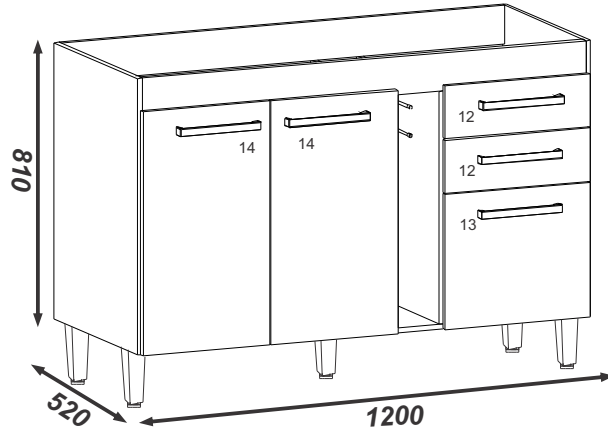

DIMENSÕES PEÇAS PRONTAS
DIMENSIONES DE LAS PEZAS PRONTAS
DIMENSIONS READY MADE PARTS

- 01-681 X 500 X 12 MM
- 02-681 X 500 X 12 MM
- 03-574 X 499 X 12 MM
- 04-574 X 499 X 12 MM
- 05-1176 X 499 X 12 MM
- 06-667 X 386 X 12 MM
- 07-338 X 95 X 12 MM
- 08-328 X 65X 12 MM
- 09-1176 X 95 X 15 MM
- 10-1176 X 95 X 15 MM
- 11-109 X 95 X 15 MM
- 12-384 X 147 X 15 MM
- 13-384 X 300 X 15 MM
- 14-600 X 336 X 15 MM
- 15-680 X 295 X 3 MM
- 16-590 X 391 X 3 MM
- 17-590 X 121 X 3 MM
- 18-350 X 341 X 3 MM

- 01-Left Side
- 02-Right Side
- 03-Left Division
- 04-Right Division
- 05-Lower Top
- 06-Shelf
- 07-Drawer Side (4x)
- 08-Drawer Back (2x)
- 09-Front Traverse
- 10-Back Traverse
- 11-Towel Rack Traverse
- 12-Drawer Front (2x)
- 13-Right Door
- 14-Door (2x)
- 15-Left Back Panel (2x)
- 16-Right Back Panel
- 17-Close Back Panel
- 18-Drawer Bottom (2x)

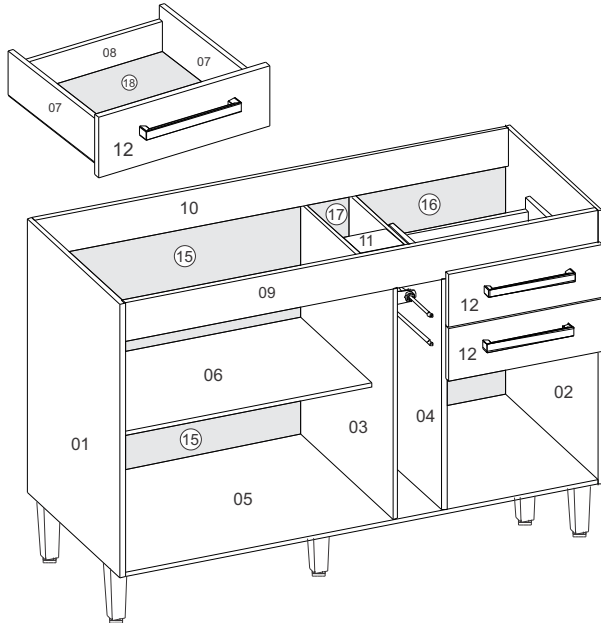

- 01-Lateral Izquierda
- 02-Lateral Derecha
- 03-División Izquierda
- 04-División Derecha
- 05-Tapa Inferior
- 06-Estante
- 07-Lateral del Cajón (4x)
- 08-Traseiro del Cajón (2x)
- 09-Travessaño Frontal
- 10-Travessaño Traseiro
- 11-Travessaño Toallero
- 12-Frente del Cajón (2x)
- 13-Puerta Derecha
- 14-Puerta (2x)
- 15-Dorso Izquierdo (2x)
- 16-Dorso Derecho
- 17-Dorso Pequeño
- 18-Fondo del Cajón (2x)

MANUAL DE MONTAGEM INSTRUCCIONES DE ARMADO ASSEMBLY INSTRUCTIONS

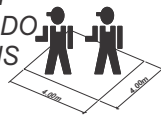

FERRAMENTAS NECESSÁRIAS
HERRAMIENTAS NECESARIAS
TOOLS NECESSARY

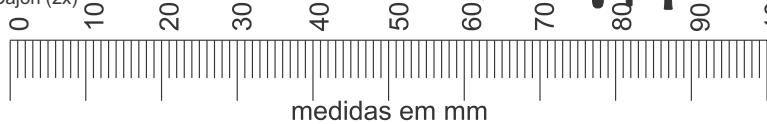

Montagem das Gavetas

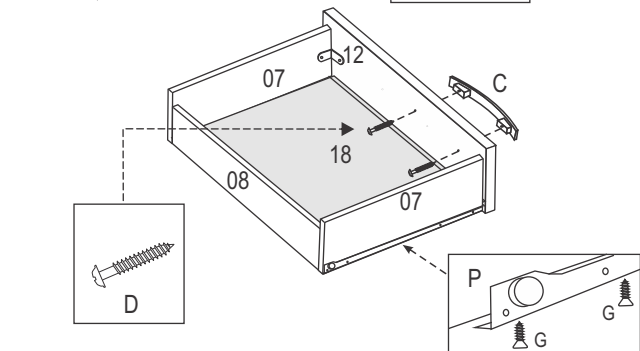
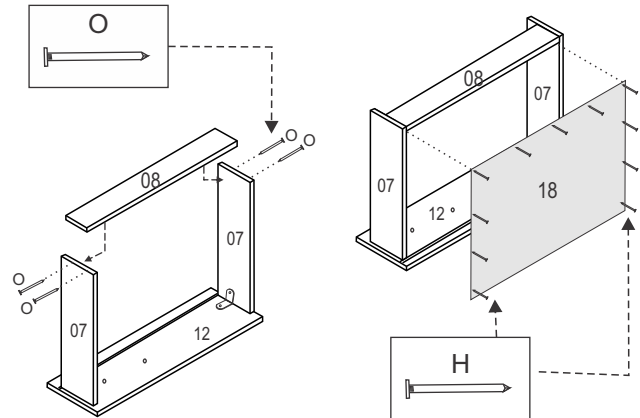
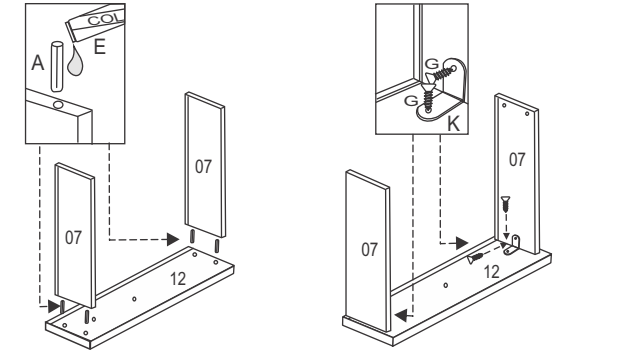

Ferragens/Herraje/Hardware:

330	A	Cavilhas 6 x 30 Wood Peg		27
0289	B	Parafuso 3,5 x 40 Tornillo Screw		16
-----	C	Puxador 192 mm Tirador Handle		05
0285	D	Parafuso 3,5 x 25 flangeado Tornillo Screw		10
0477	E	Cola Pegamento Glue		01
0283	G	Parafuso 3,5 x 12 c/c Tornillo Screw		59
0296	H	Taxa 10 x 7 Clavo 10 x 7 Nail 10 x 7		50
151	I	Dobradilha metal Bisagra Hinge		06
0538	J	Porca cilíndrica		08
0438	K	Cantoneira Esquina Cantoneira		08
-----	L	Pés Pies Feet		05
0555	M	Parafuso 5 X 50 Tornillo Screw		05
0279	N	Fixador De Costa Fixador de Espalda Fix Back		08
0744	O	Taxa 13 x 15 Clavo 13 x 15 Nail 13 x 15		08
160	P	Corrediça 350 mm Rieles Slides		02
4457	Q	Toalheiro		01

1º Passo

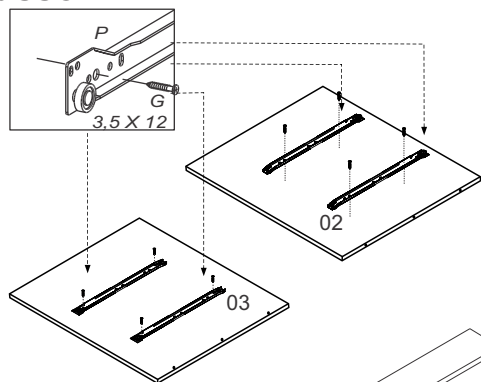

2º Passo

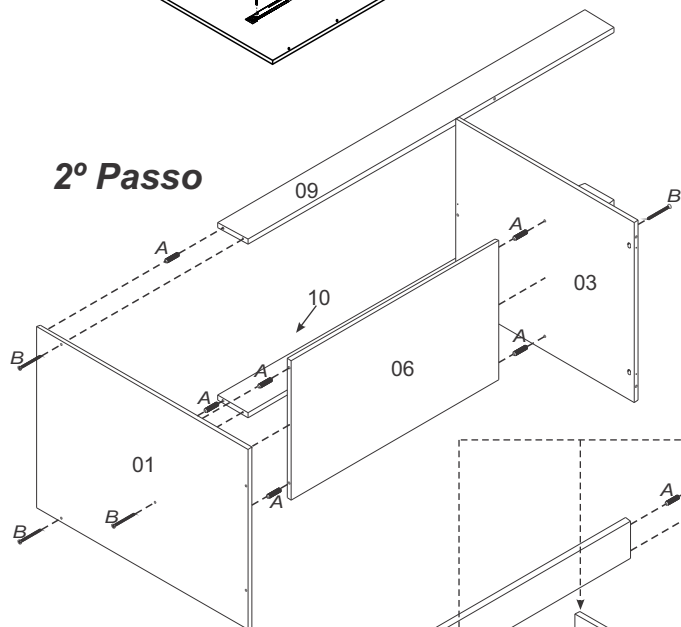

3º Passo

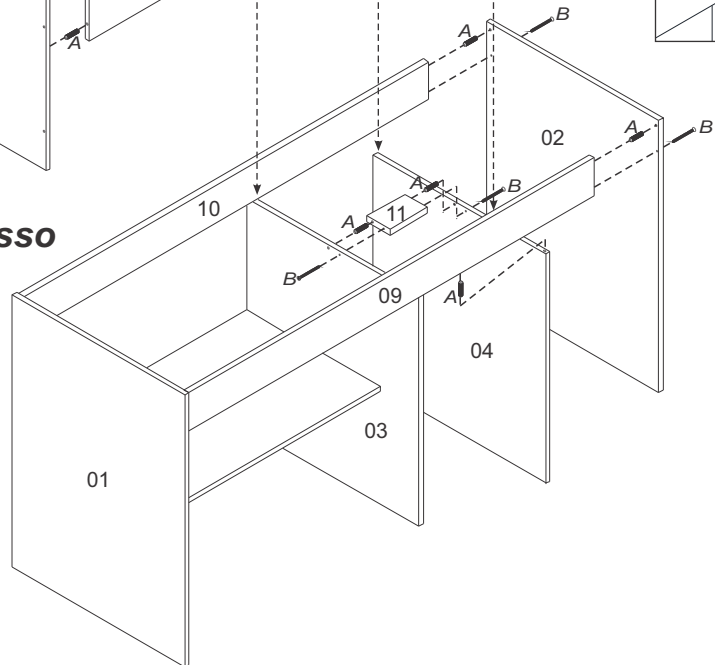

4º Passo

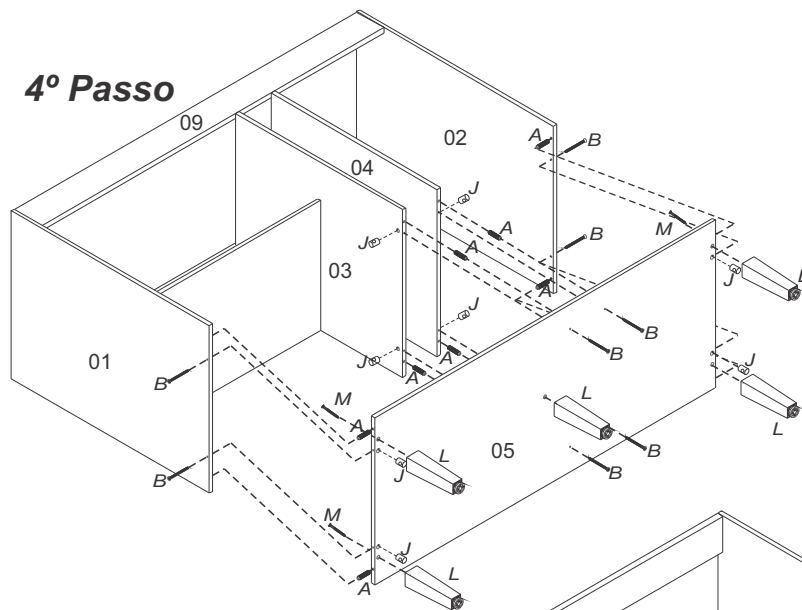

Montagem das Portas

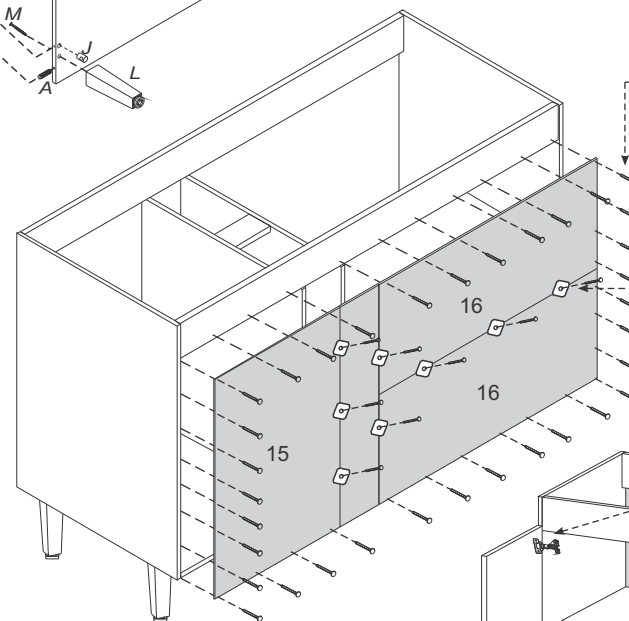
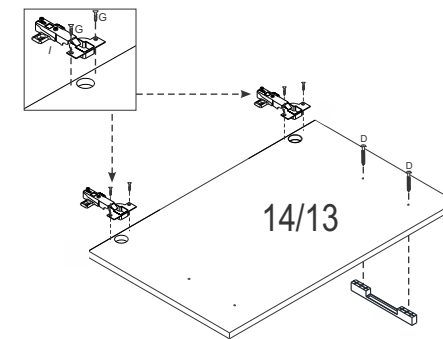

REGULAGEM / REGLAJE / ADJUSTMENT

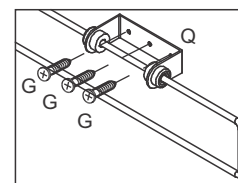
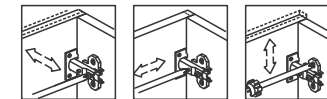

Para colocação do toalheiro,
seguir marcação da peça nº03