

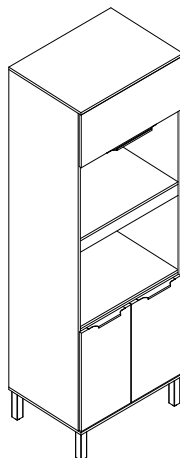

Rodovia SC-492 - Km 10 - B. Industrial
89905-000 - Bandeirante - SC
Fone: (49) 3622-4549
e-mail: mxmoveis@mxmoveis.com.br



Ref. TVE02

Torre Quente
Armario p/hornos
Cozinha/Cocina
Verace

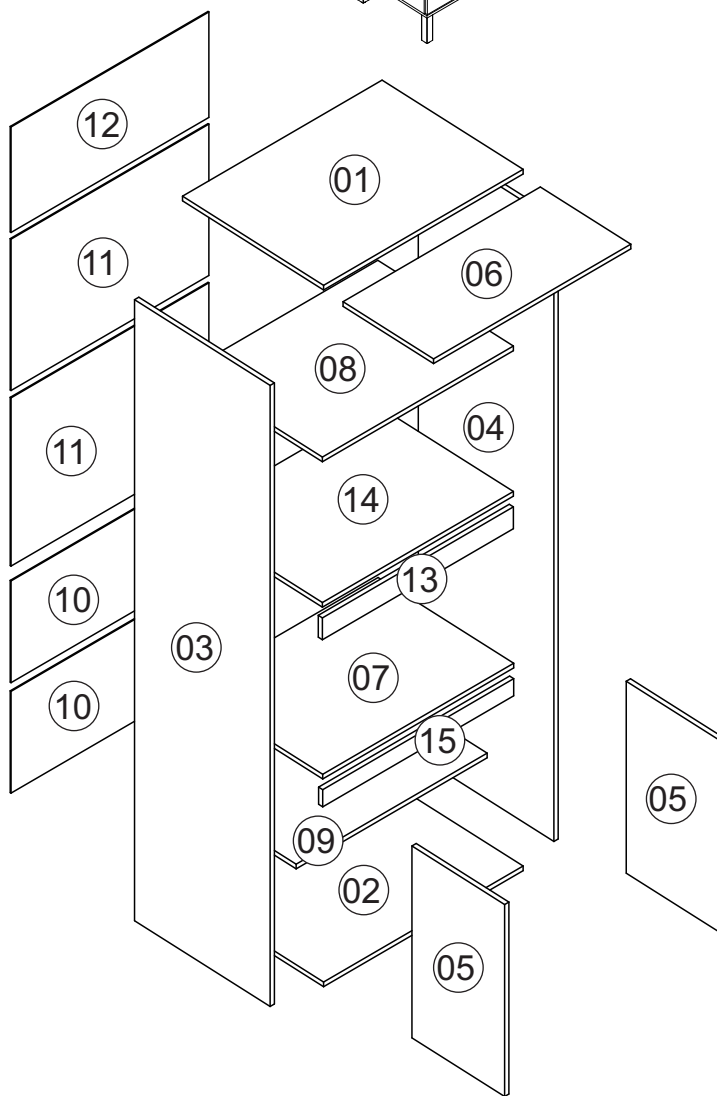

Nº	CÓDIGO ASSISTÊNCIA	NOME DA PEÇA/DESCRIPCIÓN PIEZAS	MEDIDAS (mm)	QTD.	CÓDIGO DAS PEÇAS/CÓDIGO PIEZAS					
					HAVANA	TAUPE	TAUPE	OFF WHITE	TITANIO	TAUPE
01	TVE02.05.00	Base superior/Base superior	700x516x15	01	52268		52387		48347	
02	TVE02.01.00	Base inferior/Base inferior	700x516x15	01	66143		66196		48348	
03	TVE02.18.00	Lateral externa esquerda/Lateral izquierda	1990x496x15	01	52270		52389		48349	
04	TVE02.17.00	Lateral externa direita/Lateral derecha	1990x496x15	01	52271		52390		48350	
05	TVE02.25.01	Porta/Puerta	615x339x15	02		64569		64569		48351
06	TVE02.25.00	Porta aereo basculante/Puerta	692x331x15	01		64570		64570		48352
07	TVE02.33.00	Tampo/Tapa	616x339x25	01	52393		52393		48353	
08	TVE02.01.01	Base basculante/Base	670x496x15	01	64571		52394		48354	
09	TVE02.27.02	Prateleira interna/Repisa	670x400x15	01	64538		47481		47481	
10	TVE02.13.01	Forro balcão/Revés	694x326x2.5	02	47482		47482		47482	
11	TVE02.13.04	Forro forno/Revés horno	694x513x2.5	02	52274		52395		48355	
12	TVE02.13.02	Forro aereo basculante/Revés superior	694x338x2.5	01	58715		58715		58715	
13	TVE02.28.00	Ripa frontal/Travesaño delantero	670x70x15	01	64958		64573		48357	
14	TVE02.02.00	Base micro/Base	670x496x15	01	52277		52398		48358	
15	TVE02.37.00	Ripa balcão/Travesaño	670x55x15	01	64559		64574		48359	

Ferragens/Herrajes

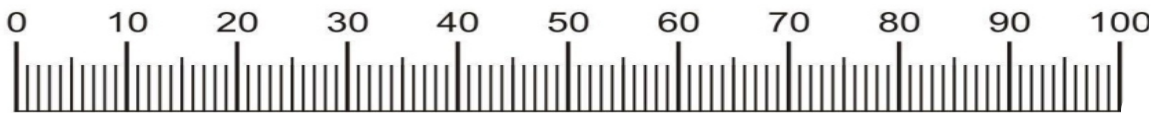
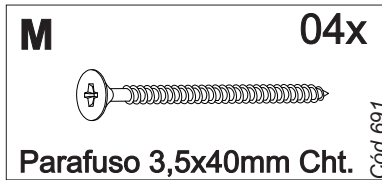
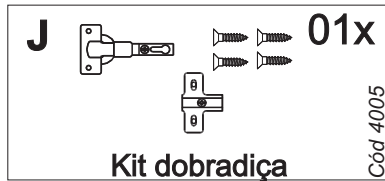
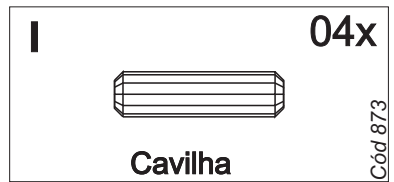
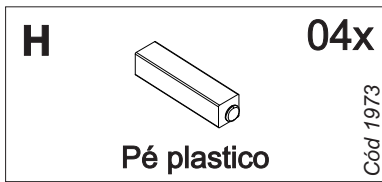
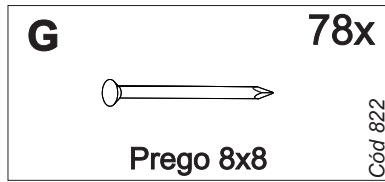
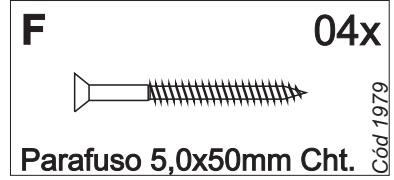
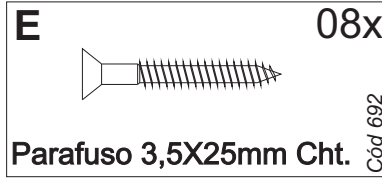
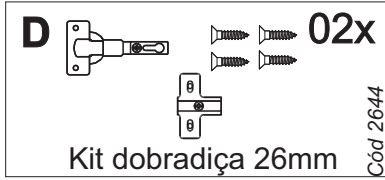
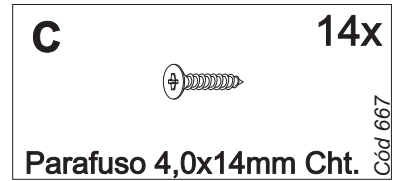
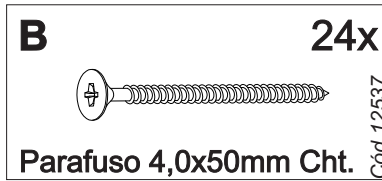
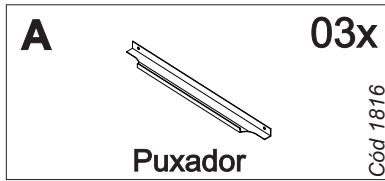

Medidas em mm

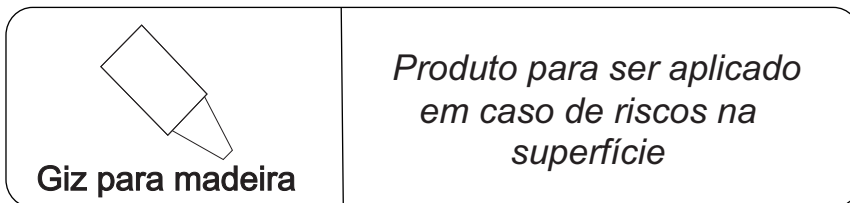
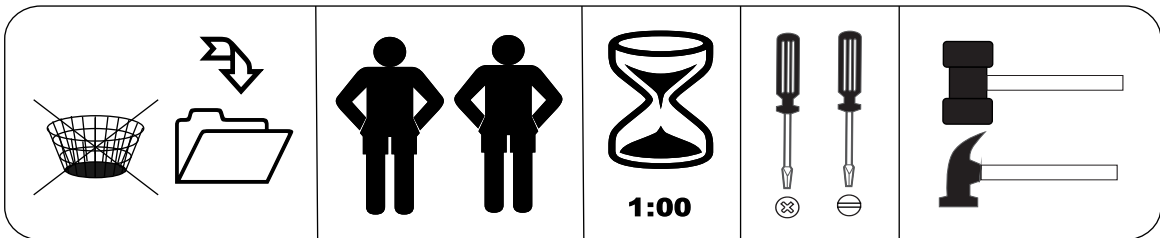

Pré-Montagem/Preparación Piezas

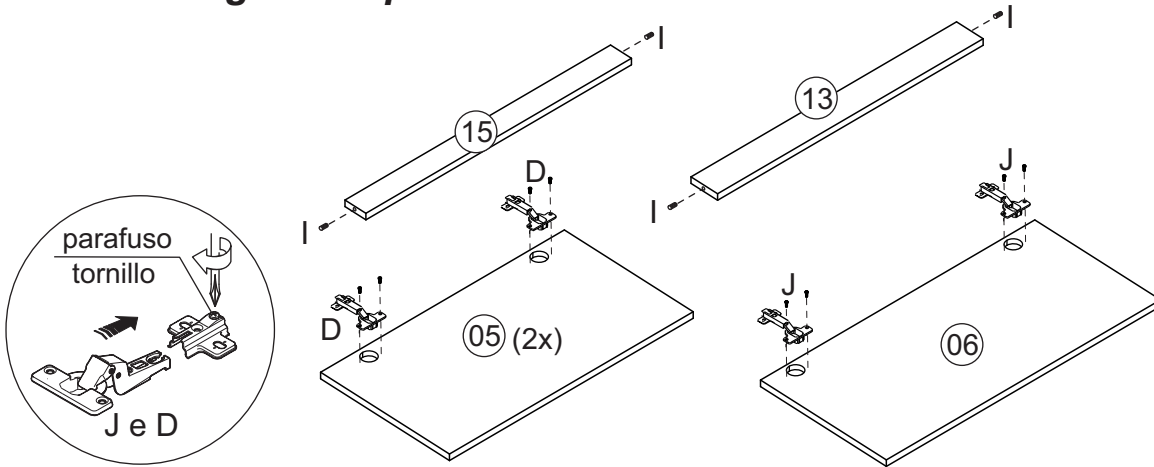

Montagem/Montaje

01

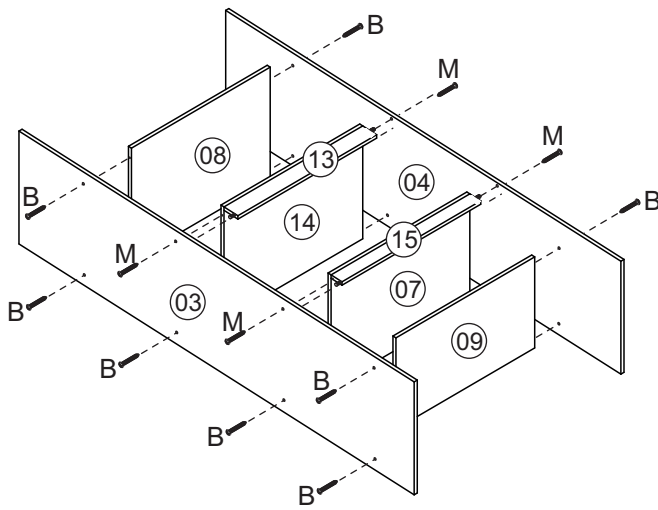

02

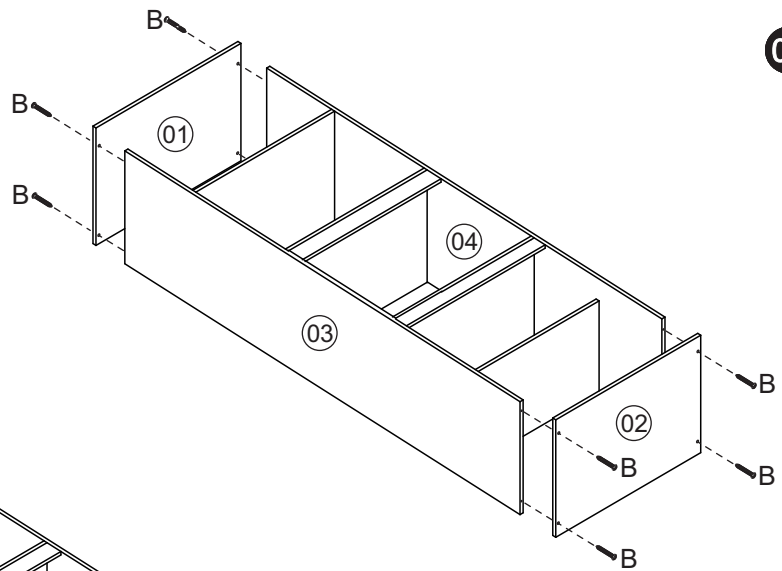

03

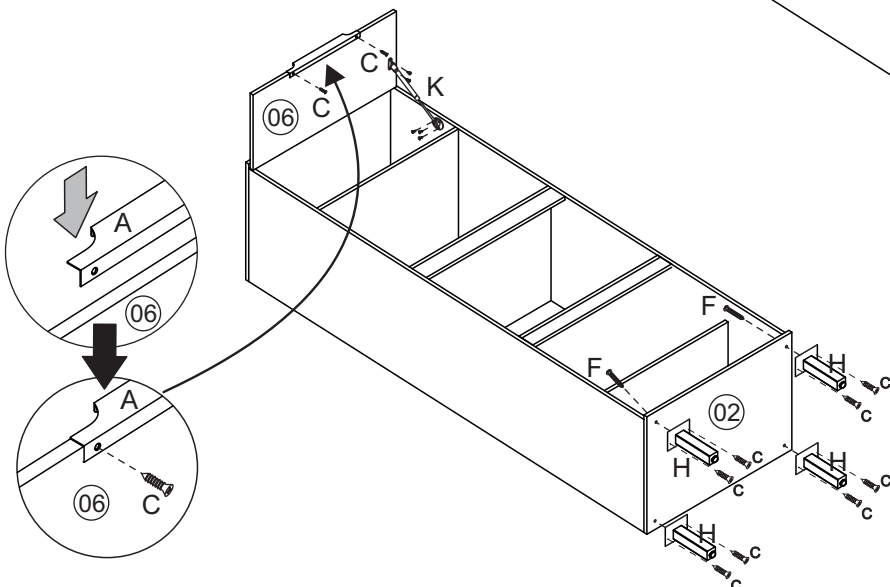

Montagem/Montaje

04

ATENÇÃO!!!

É importante colocar o móvel no esquadro antes de fixar as costas. Para isto utilize uma trena observando que a medida 1 deve ser igual à medida 2.

ATENCIÓN!!!

Es importante hacer una escuadra perfecta entre el fondo y la estructura del mueble. Observe que la medida 1 debe ser la misma que la medida 2.

Quando usar forno não fixar este forro (11)
Cuando usar el horno no utilice este revés (11)

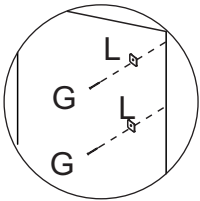
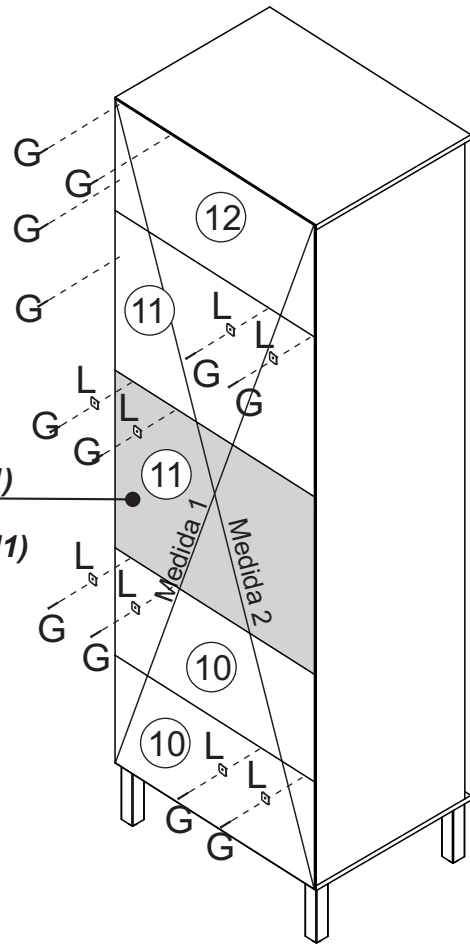

*Usar o prego (G) e a junção (L) a cada 100mm.

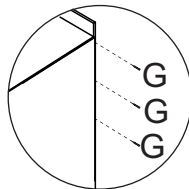

*Colocar um prego (G) a cada 100mm.

05

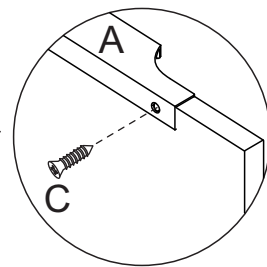
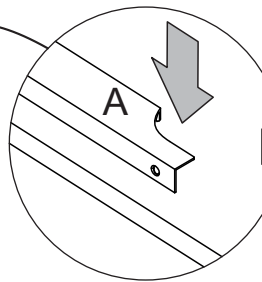
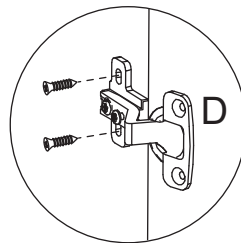
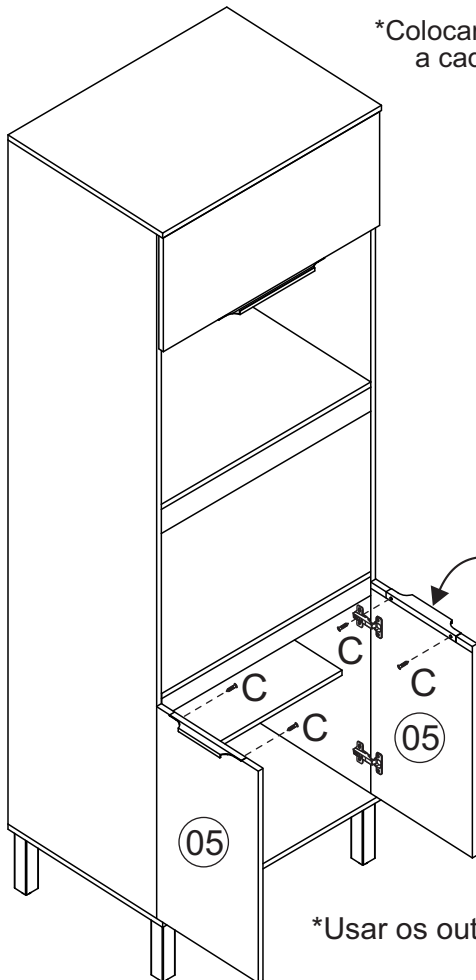

*Usar os outros 4 parafusos (E) para unir este módulo a outro.
 Usar los otros tornillos (E) para unirse este modulo a otro.

Limpeza/Limpieza

- ✘ Use um pano levemente umedecido com água, seguido de pano seco.
- ✘ Use solamente un paño húmedo con agua y después un paño seco.
- ✘ Nunca utilize produtos químicos ou abrasivos.
- ✘ No utilice productos quimicos o abrasivos.