

Aéreo Canto
Armario Esquinero
Cozinha/Cocina
Verace

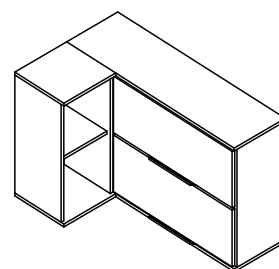

Direito/Derecho

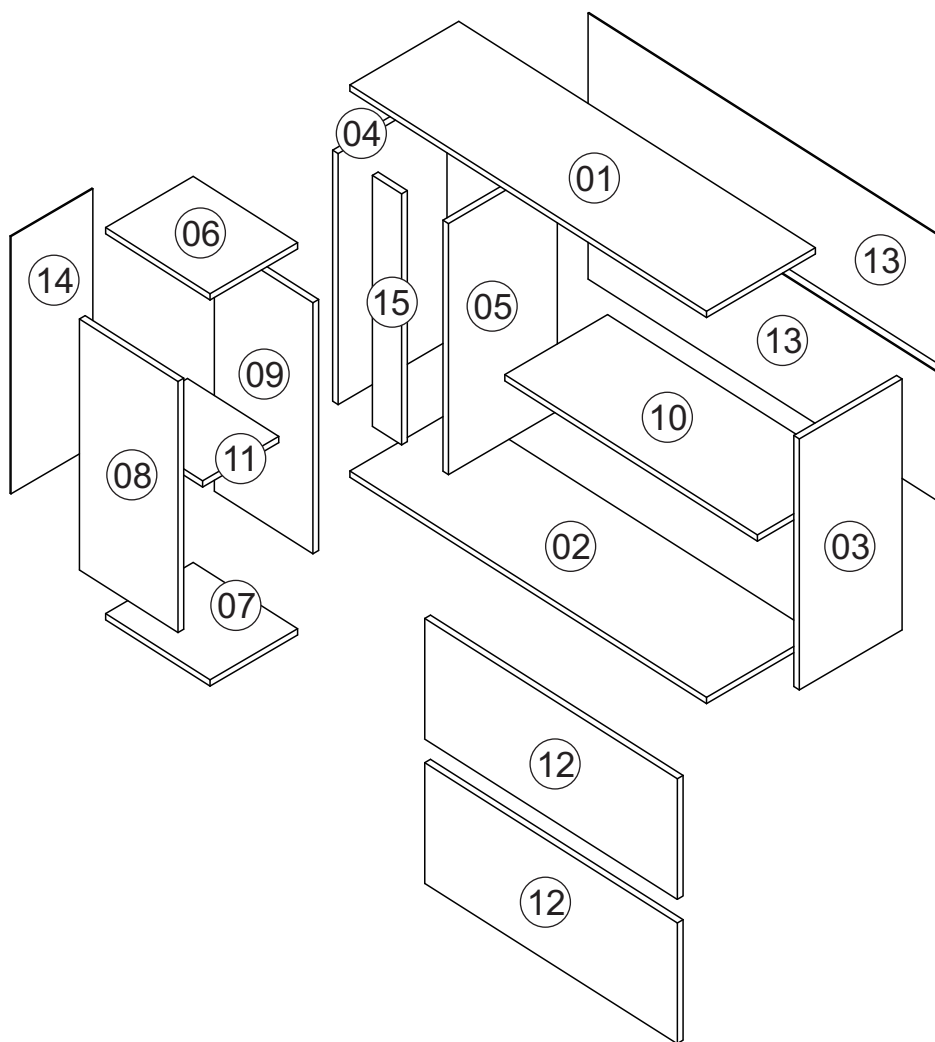

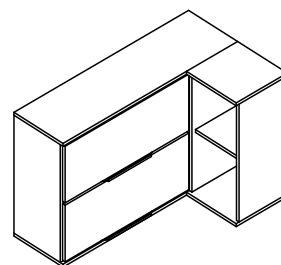

Esquerdo/Izquierdo

| Nº | CÓDIGO ASSISTÊNCIA | NOME DA PEÇA/DESCRIPCIÓN PIEZAS | MEDIDAS (mm) | QTD. | CÓDIGO DAS PEÇAS/CÓDIGO PIEZAS | | | | | |
|----|--------------------|------------------------------------------|--------------|------|--------------------------------|-------|-------|-----------|---------|-------|
| | | | | | HAVANA | TAUPE | TAUPE | OFF WHITE | TITANIO | TAUPE |
| 01 | AVE06.05.00 | Base superior/Base superior | 977x286x15 | 01 | 48100 | | 53308 | | 51628 | |
| 02 | AVE06.01.00 | Base inferior/Base inferior | 977x286x15 | 01 | 48101 | | 53309 | | 51629 | |
| 03 | AVE06.18.00 | Lateral menor/Lateral pequeña | 600x270x15 | 01 | 48102 | | 53310 | | 51630 | |
| 04 | AVE06.17.00 | Lateral maior/Lateral mayor | 600x286x15 | 01 | 48103 | | 53311 | | 51631 | |
| 05 | AVE06.19.00 | Lateral interna/Divisoria | 600x286x15 | 01 | 48104 | | 53312 | | 51632 | |
| 06 | AVE06.05.01 | Base superior/Base superior | 290x286x15 | 01 | 48105 | | 53313 | | 51633 | |
| 07 | AVE06.01.01 | Base inferior/Base inferior | 290x286x15 | 01 | 48106 | | 53314 | | 51634 | |
| 08 | AVE06.18.01 | Lateral adega esquerda/Lateral izquierda | 600x270x15 | 01 | 48107 | | 53315 | | 51635 | |
| 09 | AVE06.17.01 | Lateral adega direita/Lateral derecha | 600x270x15 | 01 | 48108 | | 53316 | | 51636 | |
| 10 | AVE06.27.00 | Prateleira interna/Repisa | 684x270x15 | 01 | 48109 | | 64674 | | 64707 | |
| 11 | AVE06.27.01 | Prateleira adega/Repisa | 260x255x15 | 01 | 48110 | | 53318 | | 51638 | |
| 12 | AVE06.25.00 | Porta/Puerta | 692x290x15 | 02 | | 64696 | | 64675 | | 64696 |
| 13 | AVE06.13.00 | Forro maior/Revés mayor | 710x313x2.5 | 02 | 47451 | | 47451 | | 47451 | |
| 14 | AVE06.13.01 | Forro adega/Revés | 620x284x2.5 | 01 | 65687 | | 65787 | | 65818 | |
| 15 | AVE06.06.00 | Ripa batente/Travesaño | 600x80x15 | 01 | 46010 | | 46010 | | 46010 | |

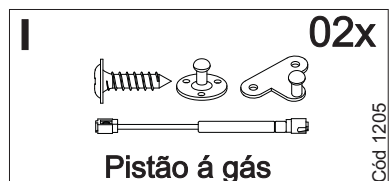
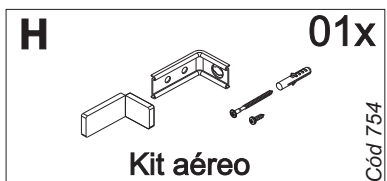
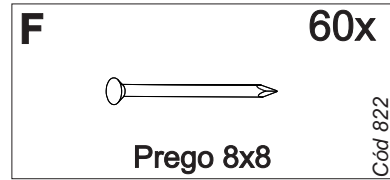
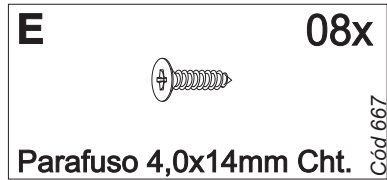
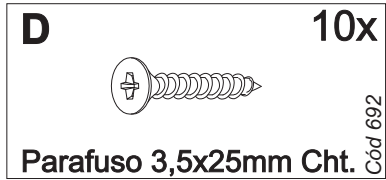
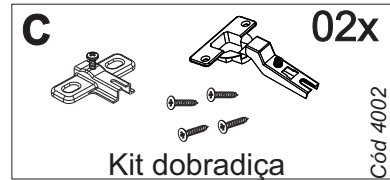
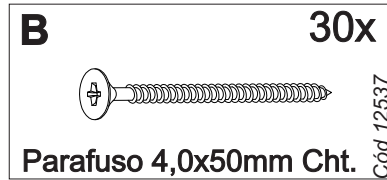
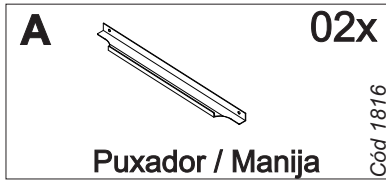
Ferragens/Herrajes



 *Usar os parafusos (D) para unir este módulo a outro. Usar los tornillos (D) para unirse este módulo a otro. 

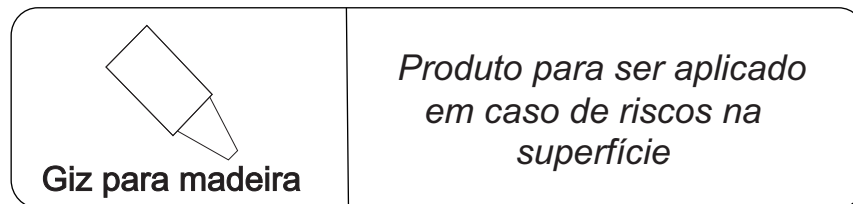
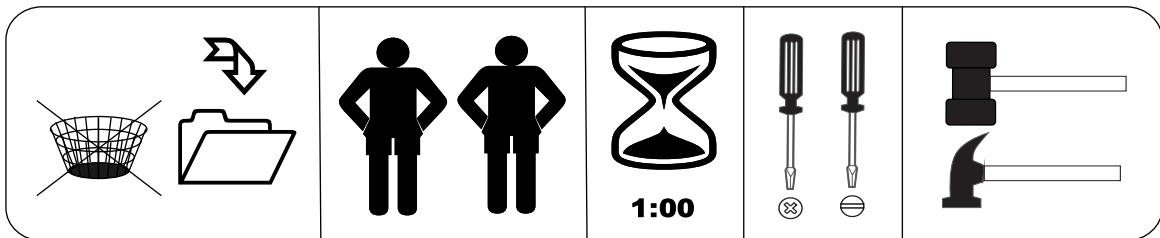

Pré-Montagem/Preparación Piezas

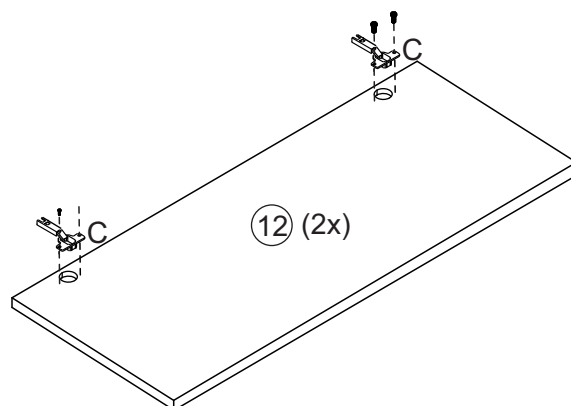

Montagem/Montaje

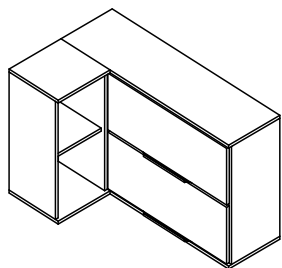

Direito/Derecho

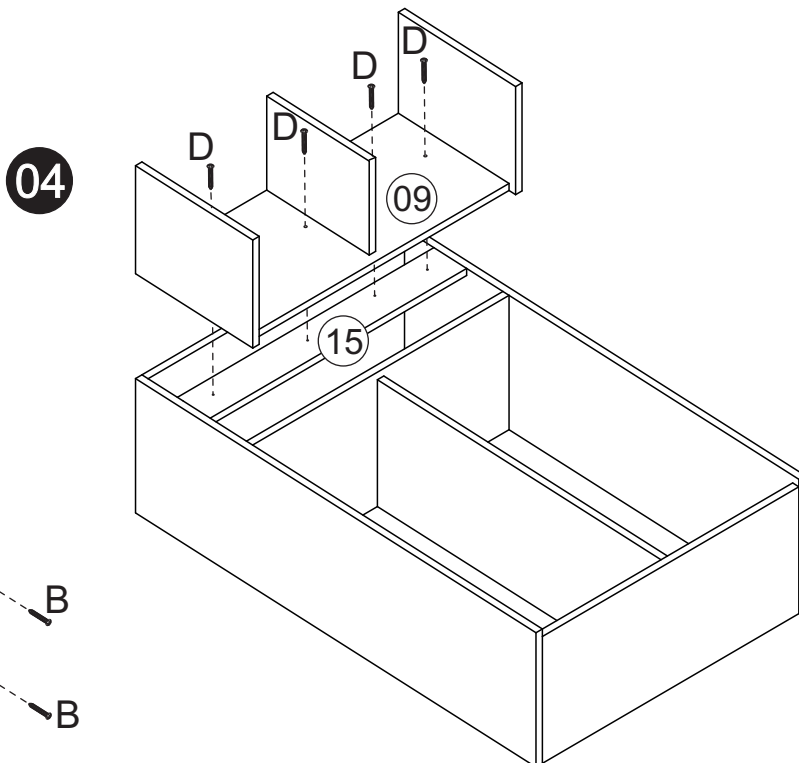
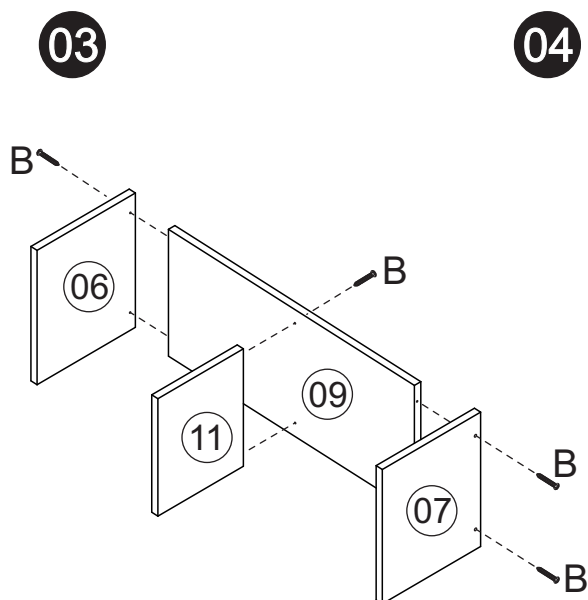
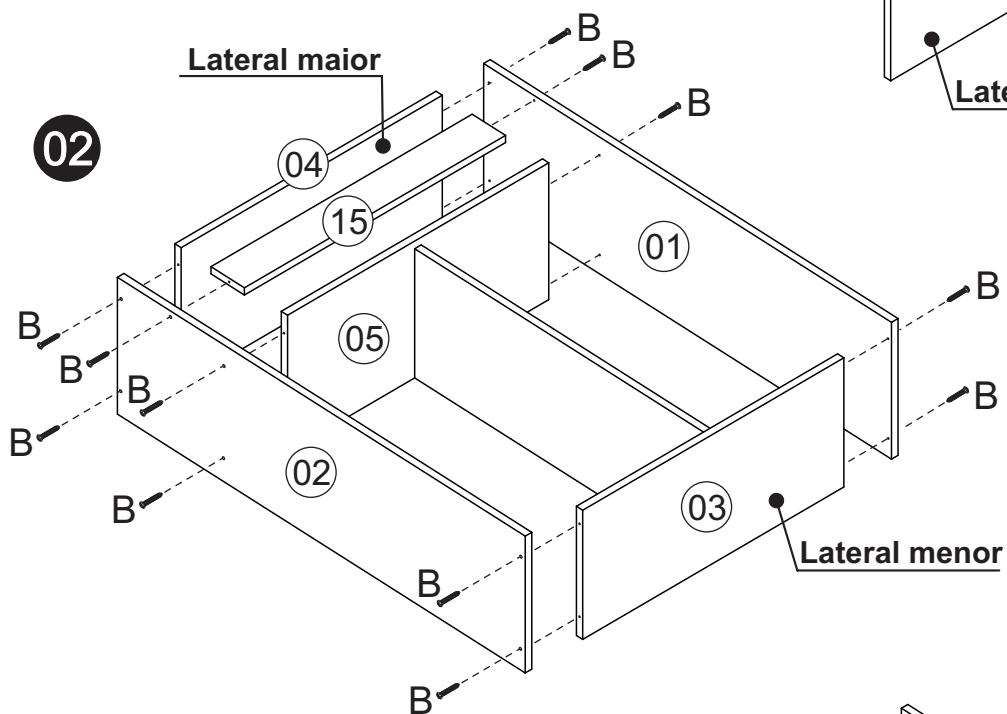
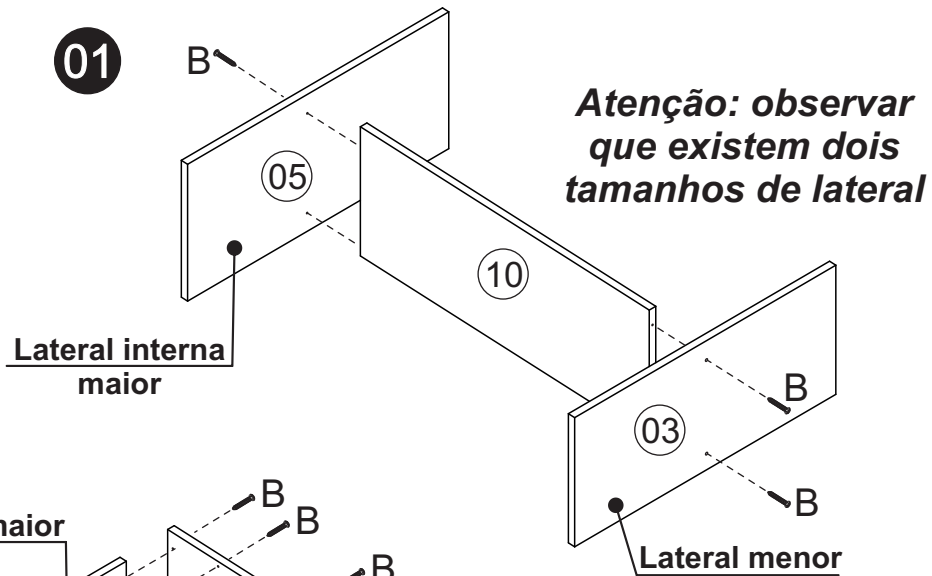

Montagem/Montaje

05

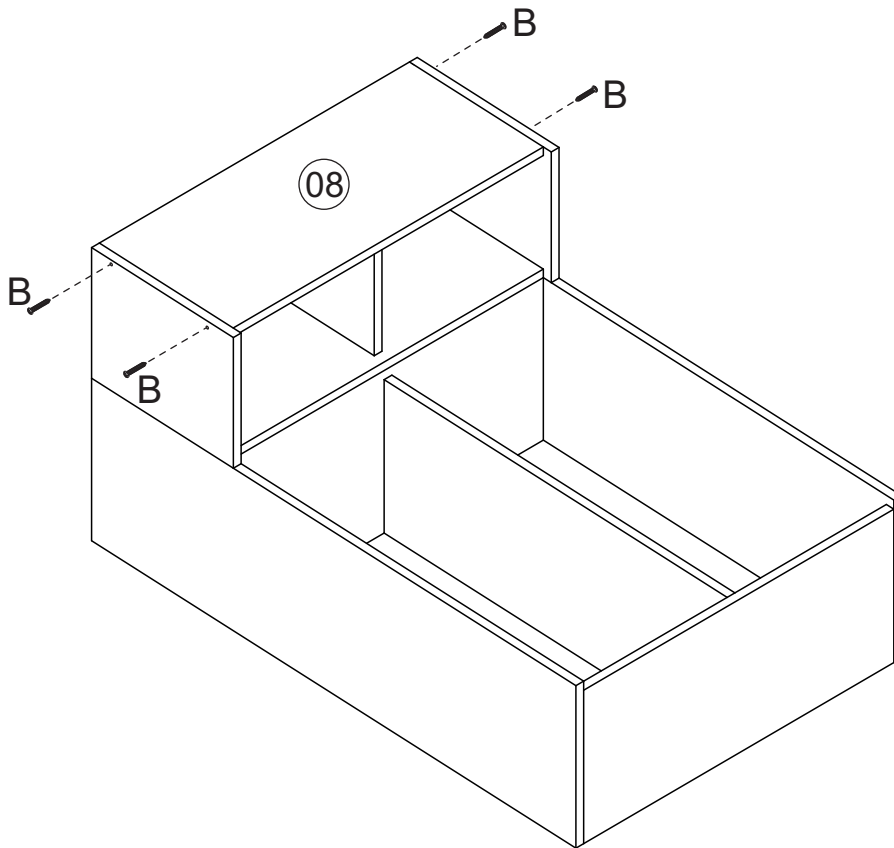

06

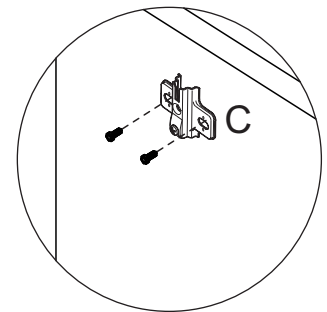
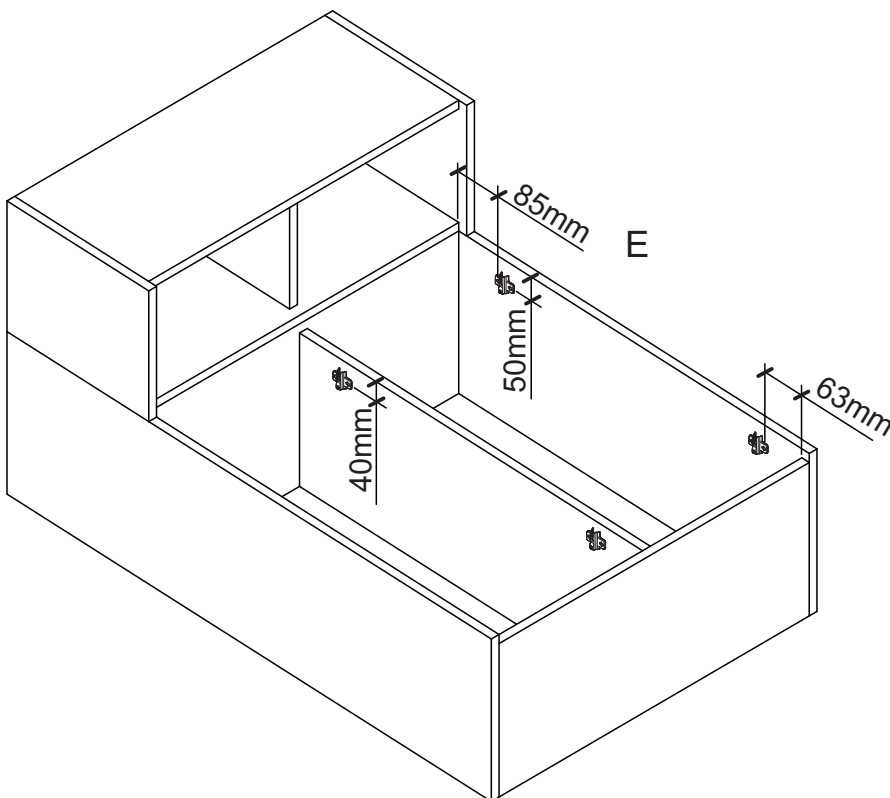

Atenção: observar medidas indicadas para fixação do calço

Montagem/Montaje

07

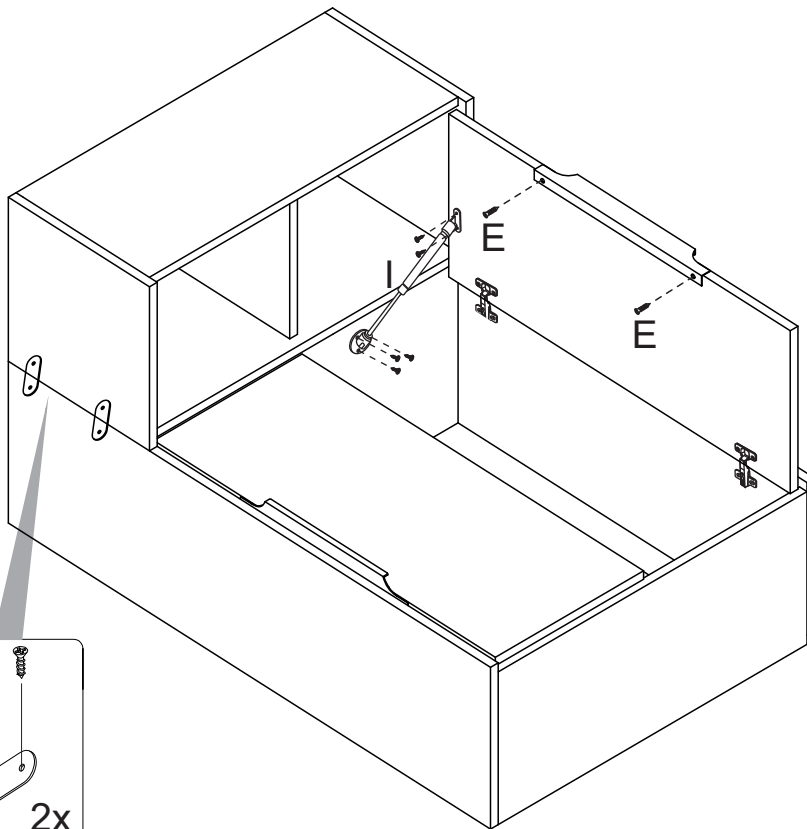

08

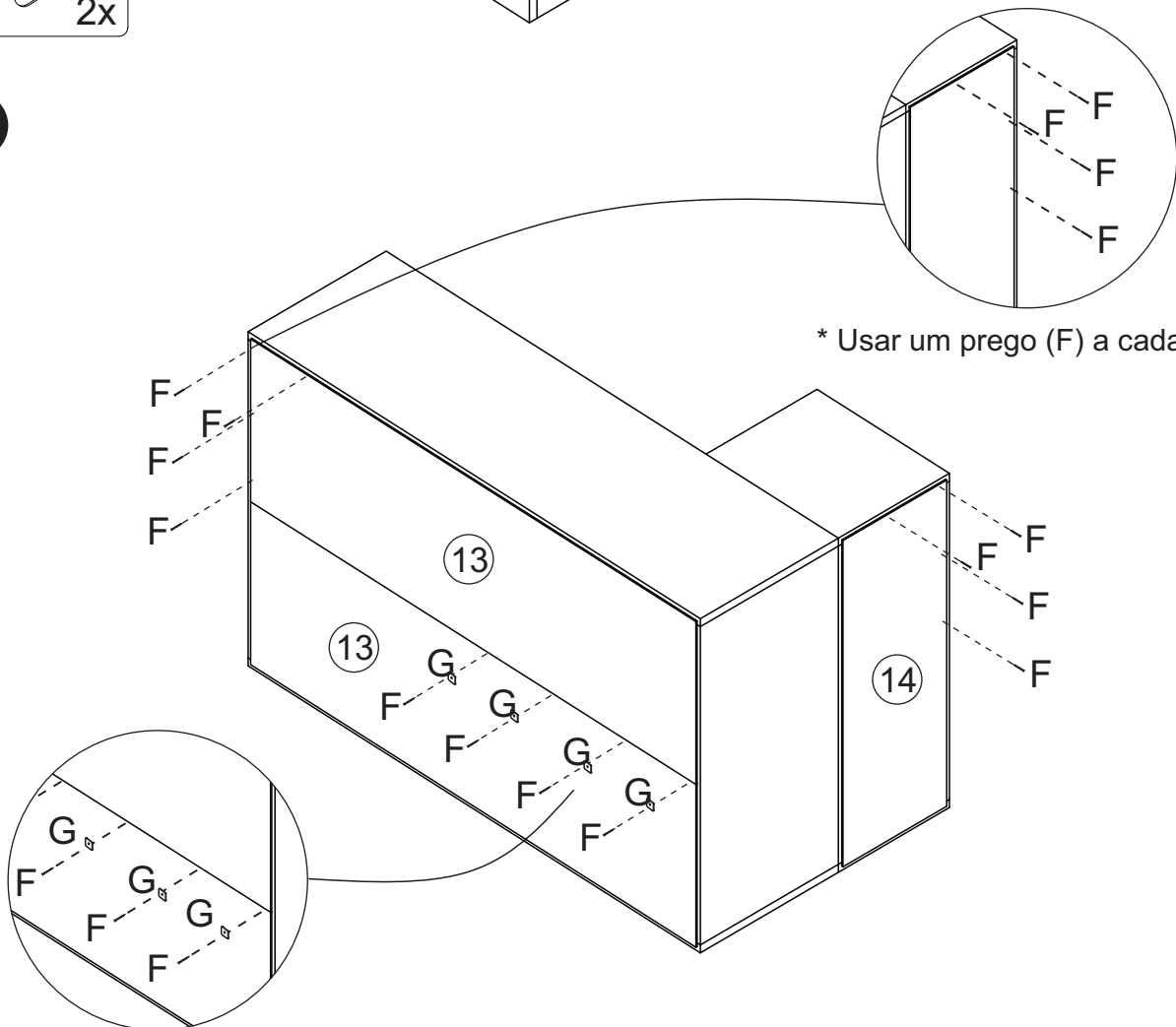

* Usar um prego (F) a cada 100mm

* Usar um prego (F) e um junção (G) a cada 100mm

Montagem/Montaje

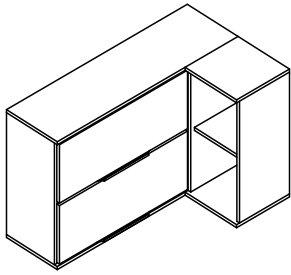

Esquerdo/Izquierdo

01

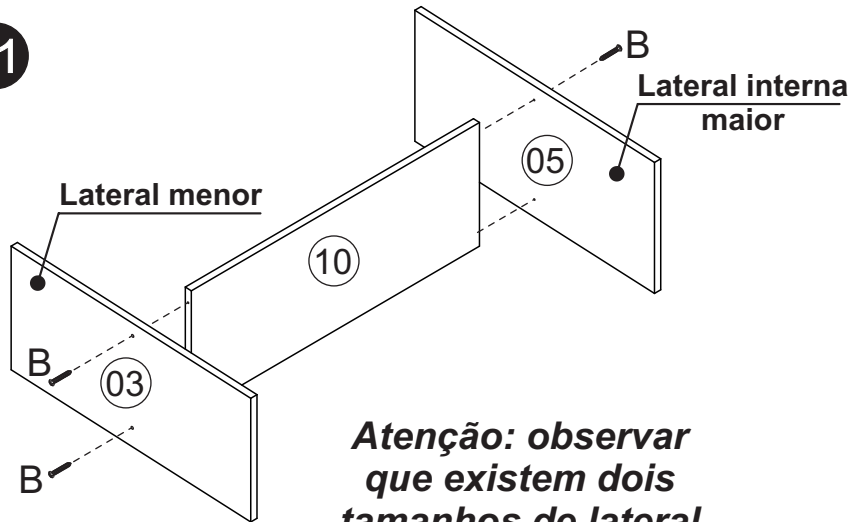

Atenção: observar que existem dois tamanhos de lateral

02

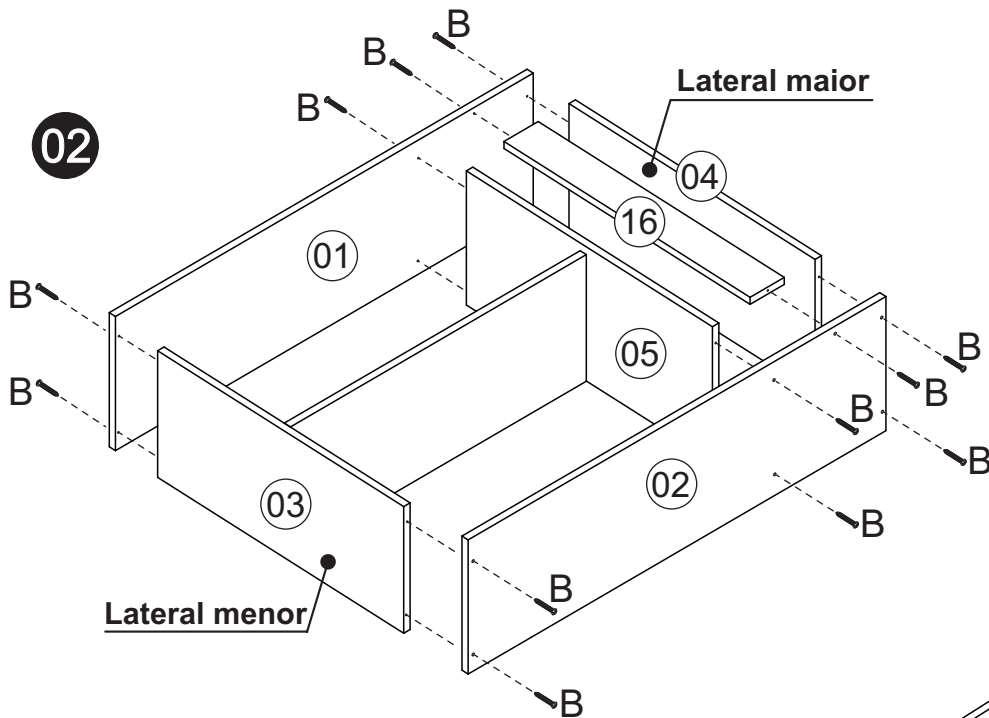

03

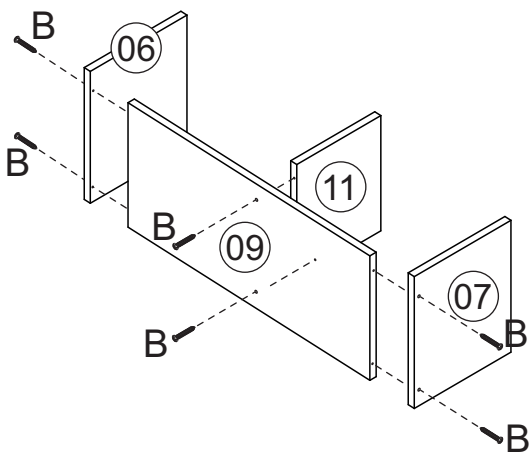

04

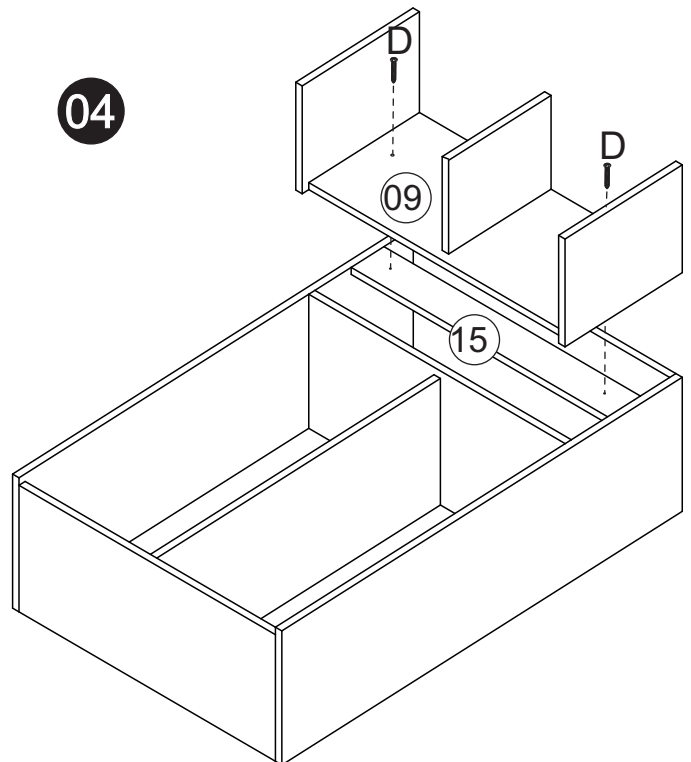

Montagem/Montaje

05

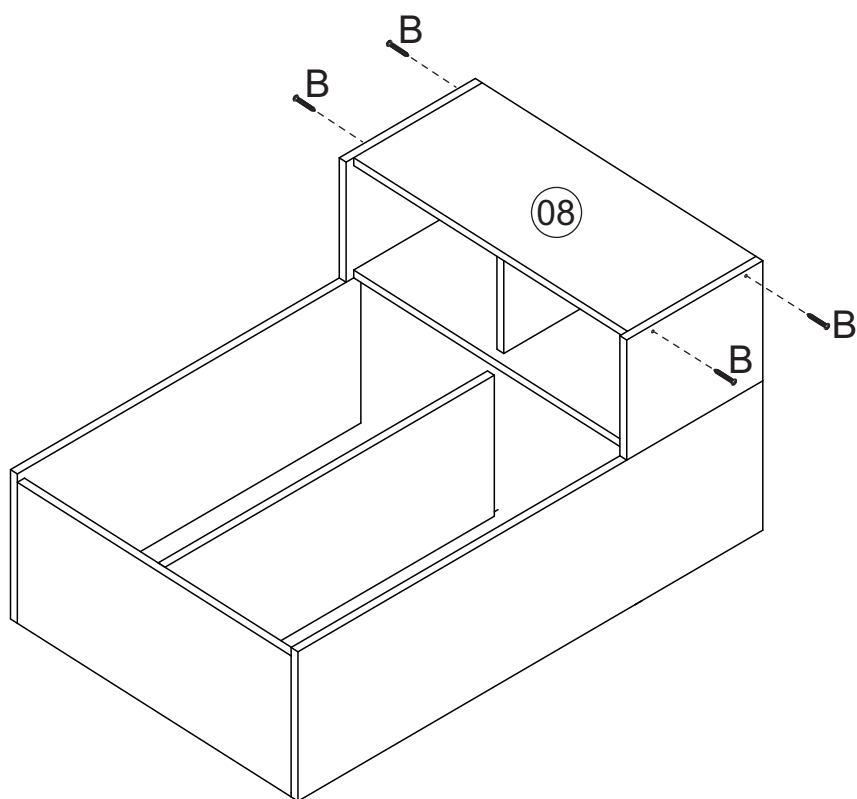

06

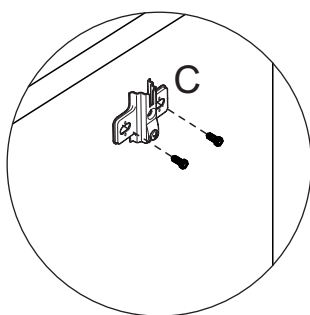

Atenção: observar medidas indicadas para fixação do calço

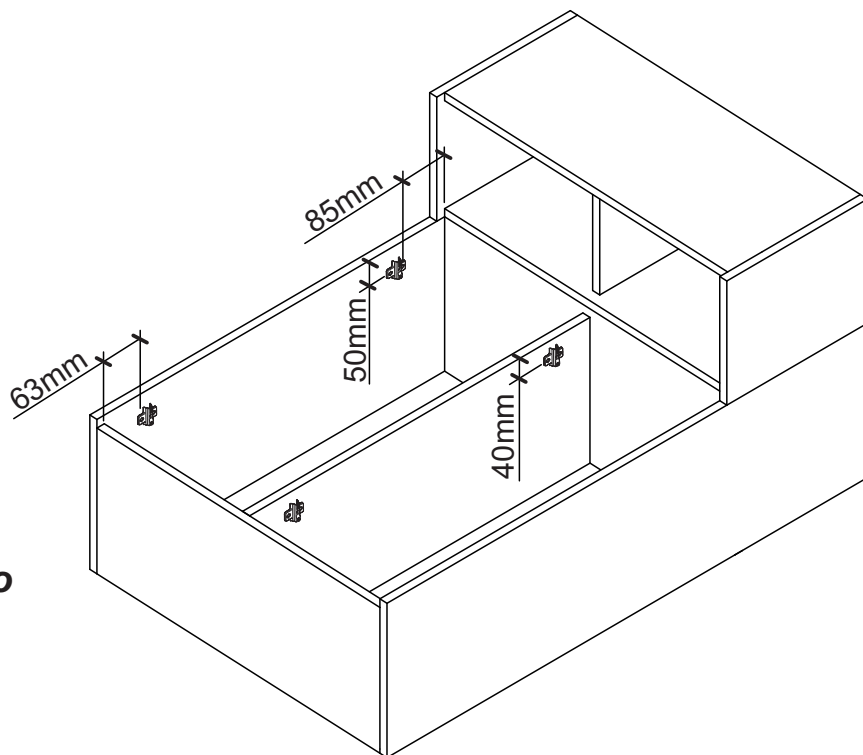

Montagem/Montaje

07

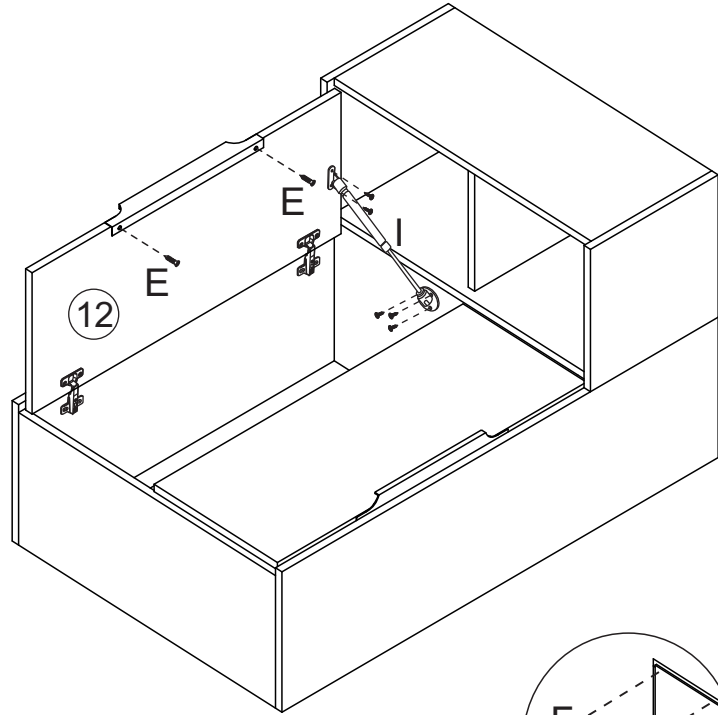
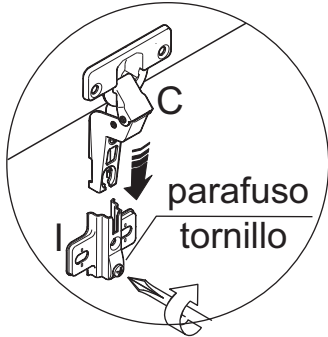

08

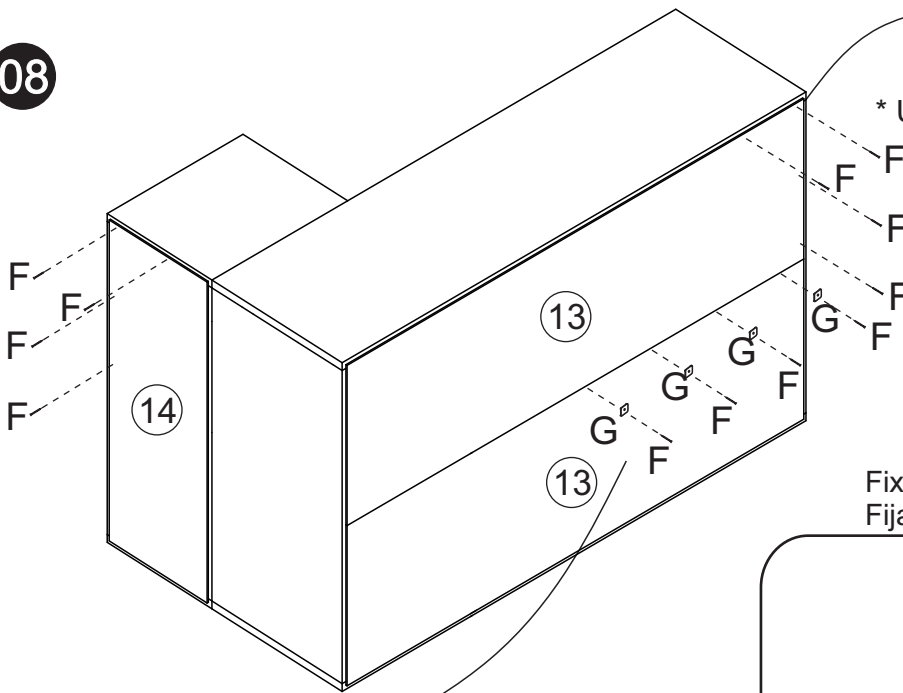

* Usar um prego (F) a cada 12mm

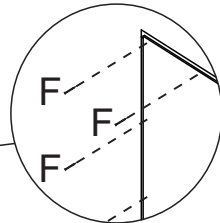

Fixação na parede
Fijación en la pared

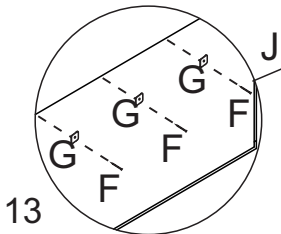
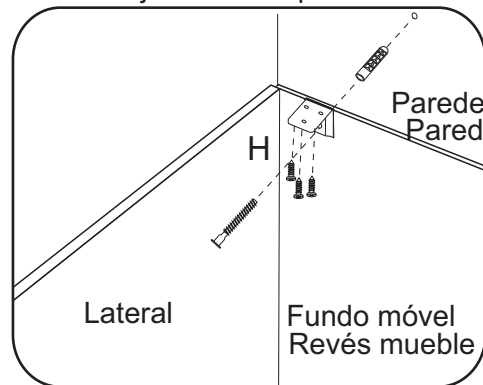

13

* Usar um prego (F) e uma junção (G) a cada 12mm

*Fixar a cantoneira na parte interna do móvel.
Fijar la pieza «L» en el interior del mueble.

*Usar os outros 4 parafusos (D) para unir este módulo a outro.
Usar los otros tornillos (D) para unirse este modulo a otro.

Limpeza/Limpieza

- ≠ Use um pano levemente umedecido com água, seguido de pano seco.
- ≠ Use solamente un paño húmedo con agua y después un paño seco.
- ≠ Nunca utilize produtos químicos ou abrasivos.
- ≠ No utilice productos químicos o abrasivos.