

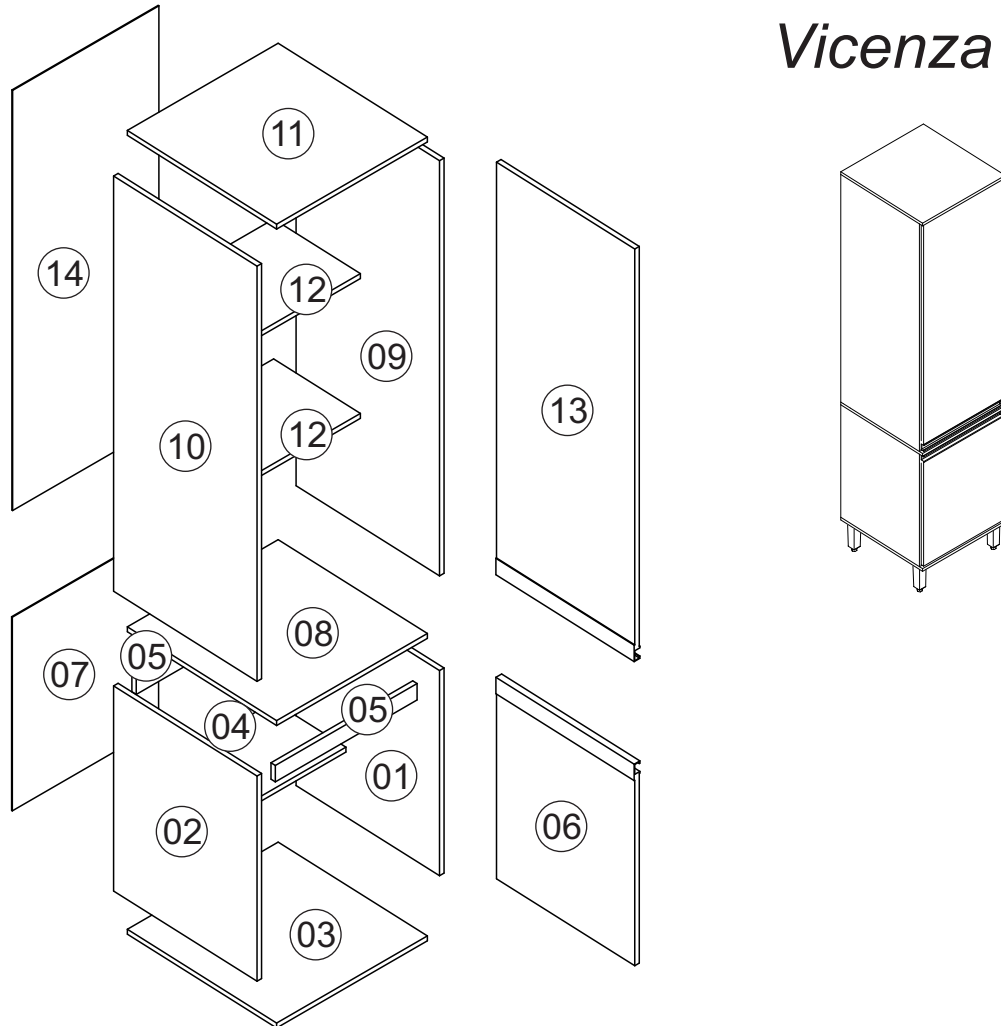

Paneleiro Cozinha Vicenza

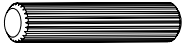

Nº	Código	NOME DA PEÇA/DESCRIPCIÓN PIEZAS	Medidas (mm)	QTD.	CÓDIGO PEÇAS/PIEZAS	
					DAKAR	SONORA
01	PVI01.17.01	Lateral balcão direita/Lateral derecha	625x496x15	01	61770	61783
02	PVI01.18.01	Lateral balcão esquerda/Lateral izquierda	625x496x15	01	61771	61784
03	PVI01.01.00	Base inferior/Base inferior	516x490x15	01	29800	35291
04	PVI01.27.01	Prateleira interna/Repisa inferior	460x250x15	01	61774	61787
05	PVI01.28.00	Ripa sustentação/Traviesa balcón	460x50x15	02	61773	66203
06	PVI01.25.01	Porta balcão/Puerta balcón	580x470x15	01	61778	61791
07	PVI01.13.01	Forro balcão/Revés balcón	596x477x2,5	01	61768	61781
08	PVI01.33.00	Tampo paneleiro/Tapa	516x490x15	01	61777	61790
09	PVI01.17.00	Lateral paneleiro direito/Lateral superior derecho	1265x496x15	01	61769	61782
10	PVI01.18.00	Lateral paneleiro esquerdo/Lateral superior izquierdo	1265x496x15	01	61776	61789
11	PVI01.05.00	Base superior/Base superior	516x490x15	01	61775	61788
12	PVI01.27.00	Prateleira paneleiro/Repisa superior	460x300x15	02	61772	61785
13	PVI01.25.00	Porta paneleiro/Puerta superior	1221x470x15	01	61779	61791
14	PVI01.13.00	Forro superior /Revés superior	1288x477x2,5	01	61767	61780

Ferragens/Herrajes

A  **08x**
Cavilha Ø6,0x30mm Cód 873

B  **24x**
Parafuso 4,0x50mm Cht. Cód 12537

C  **02x**
Puxador/Manija Cód 827

D  **01x**
Kit dobradiça 26mm Cód 2644

E  **12x**
Parafuso 4,0x14mm Cht. Cód 667

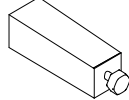
F  **04x**
Pé plástico Everest Cód 796

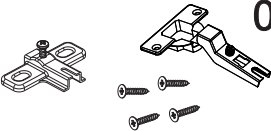
G  **01x**
Kit dobradiça 26mm Cód 3278

H  **04x**
Parafuso 5,0x50mm Cht. Cód 1979

I  **08x**
Parafuso 3,5x25mm Cht. Cód 692

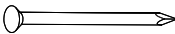
J  **50x**
Prego 8x8 Cód 822

K  **04x**
Cantoneira metálica Cód 7847

L  **04x**
Parafuso 4,0x40mm Cht. Cód 691



M  **13x**
Parafuso 3,5x12mm Cht. Cód 808



*Usar os parafusos (I) para unir este módulo a outro.
Usar los tornillos (I) para unirse este módulo a otro.

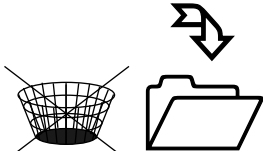
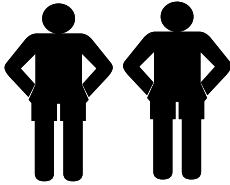

Medidas em mm

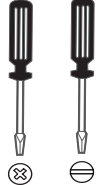
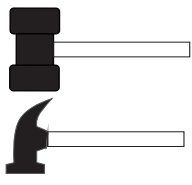
				
---	---	---	--	---

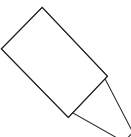
	<p>Produto para ser aplicado em caso de riscos na superfície</p>
---	--

Pré-Montagem/Preparación Piezas

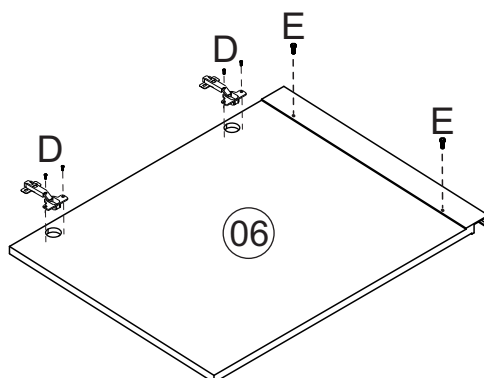
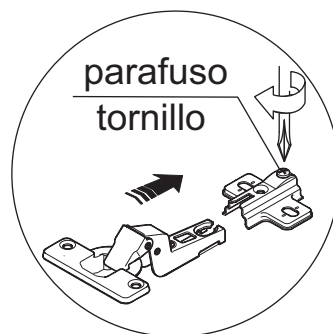
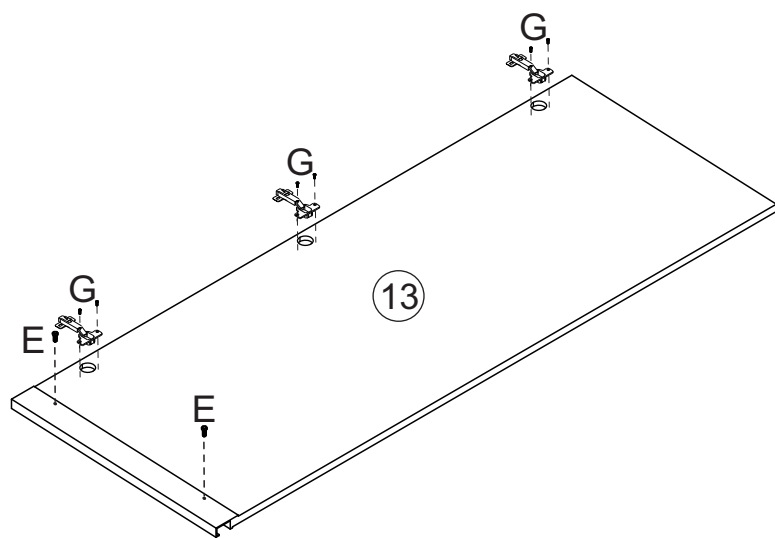
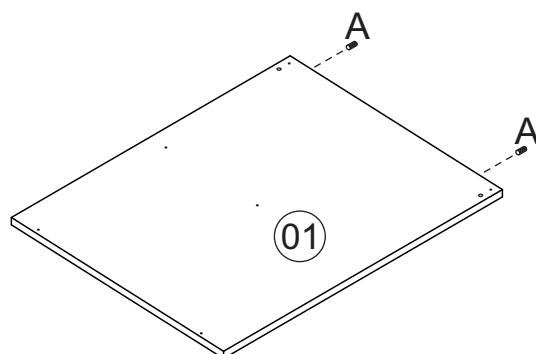
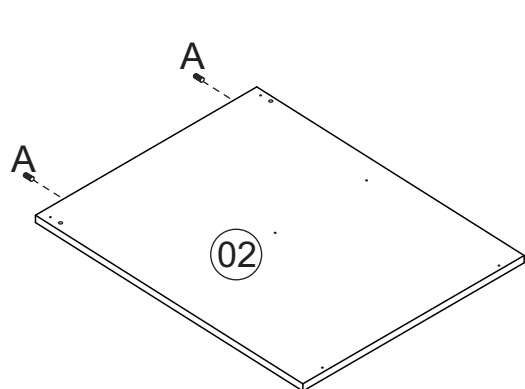
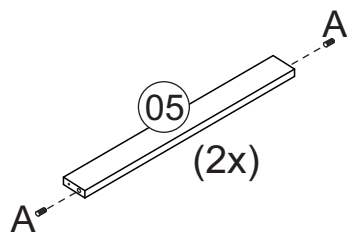

Montagem/Montaje

01

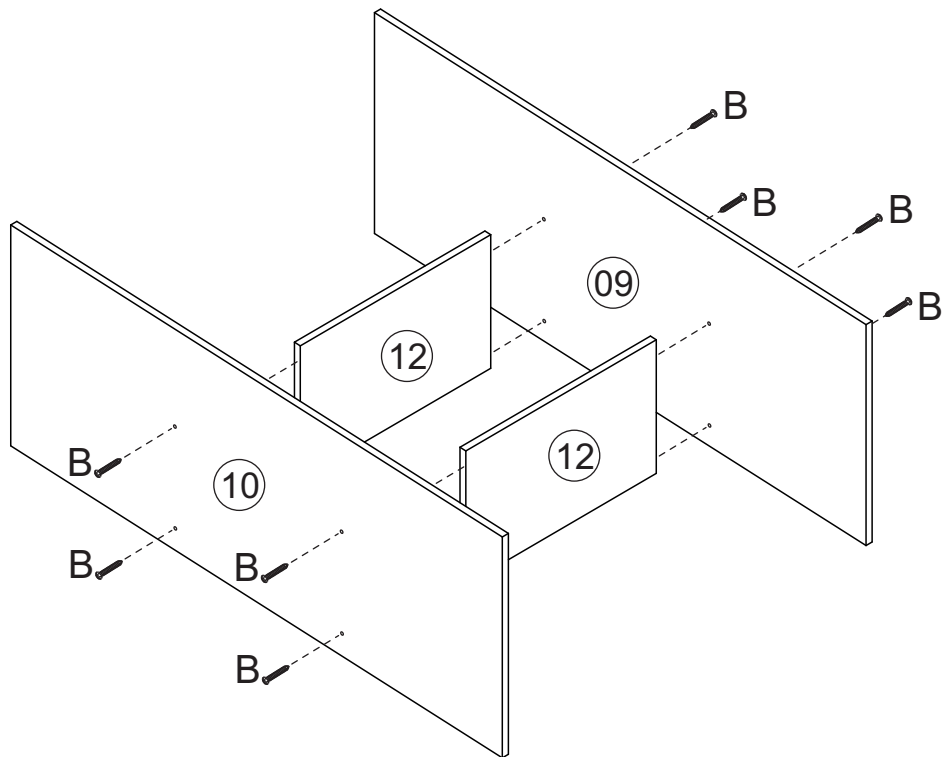

02

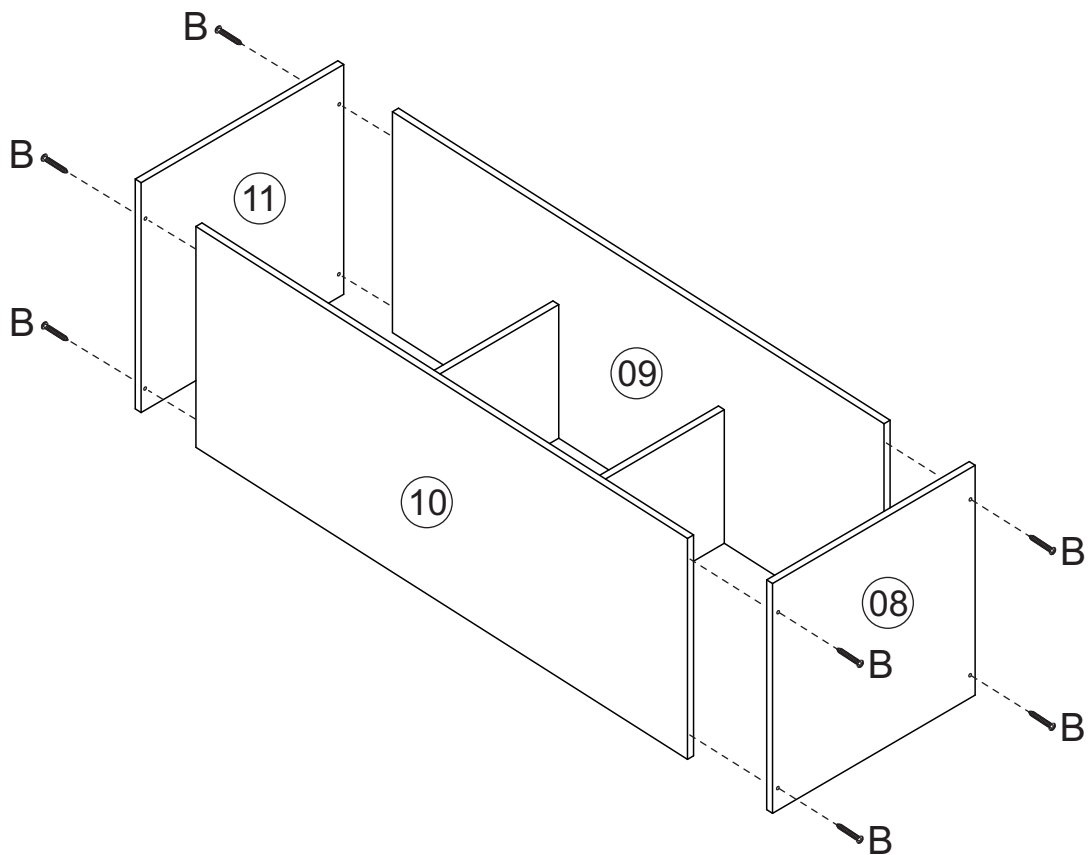

Montagem/Montaje

03

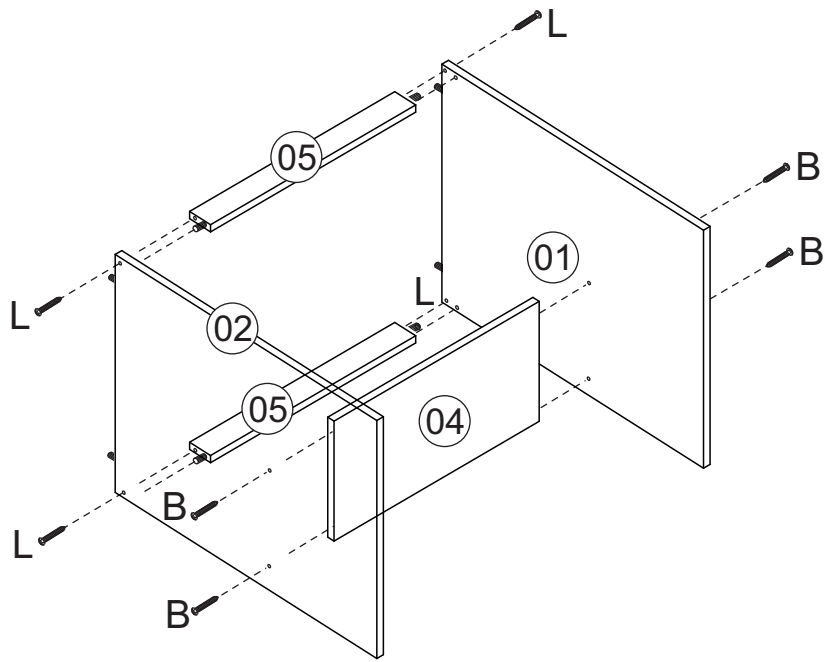

04

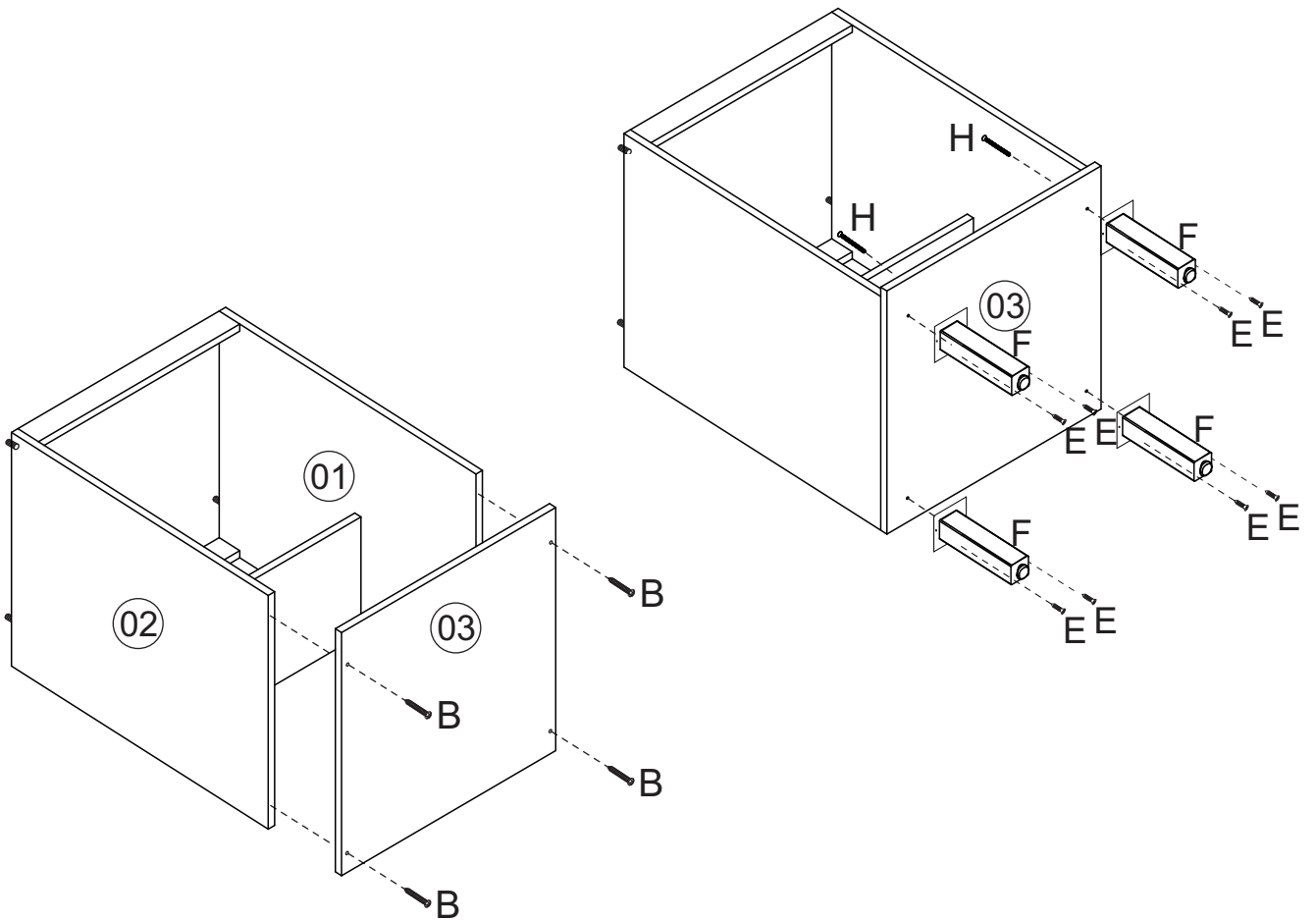

Montagem/Montaje

05

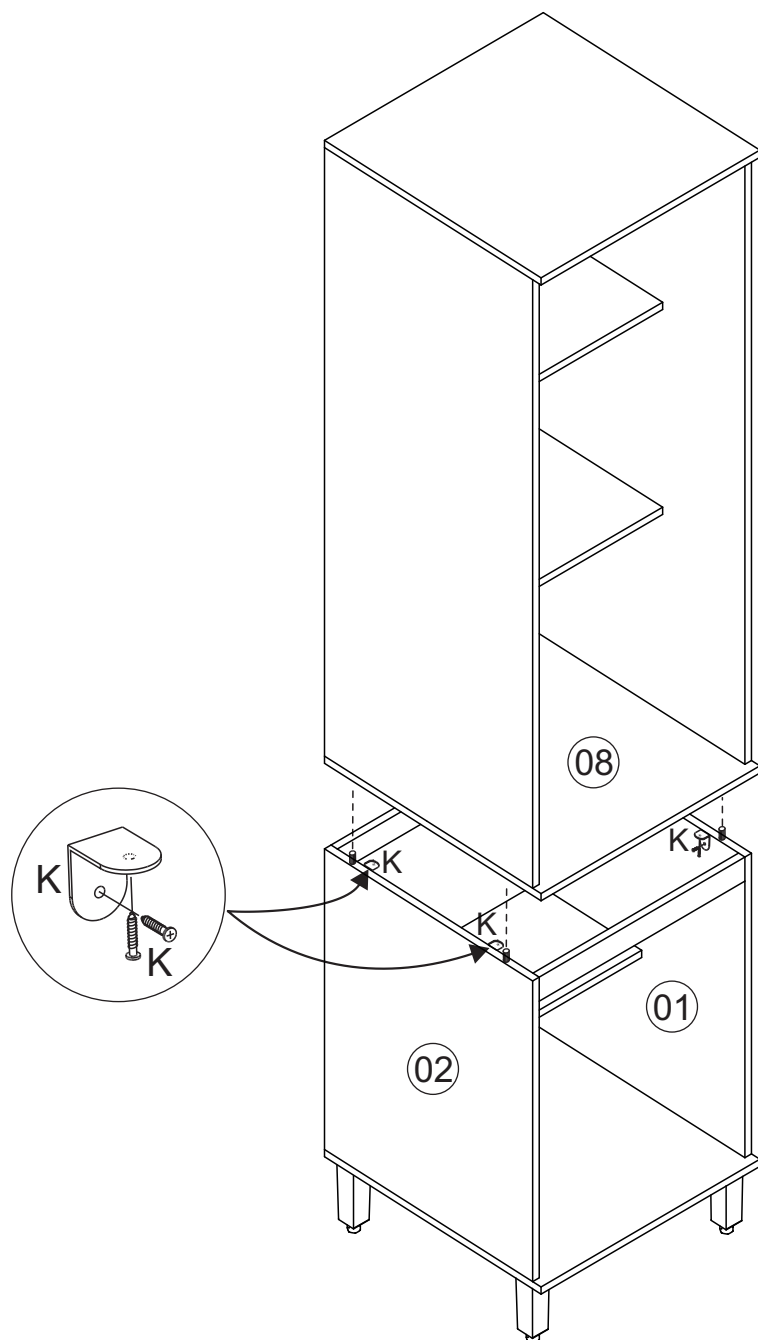

Montagem/Montaje

06

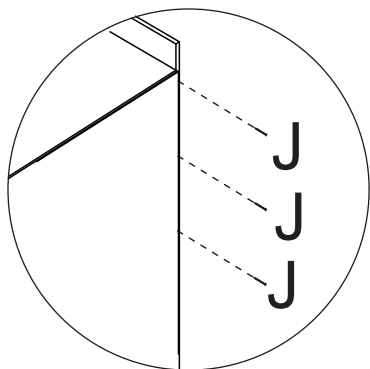
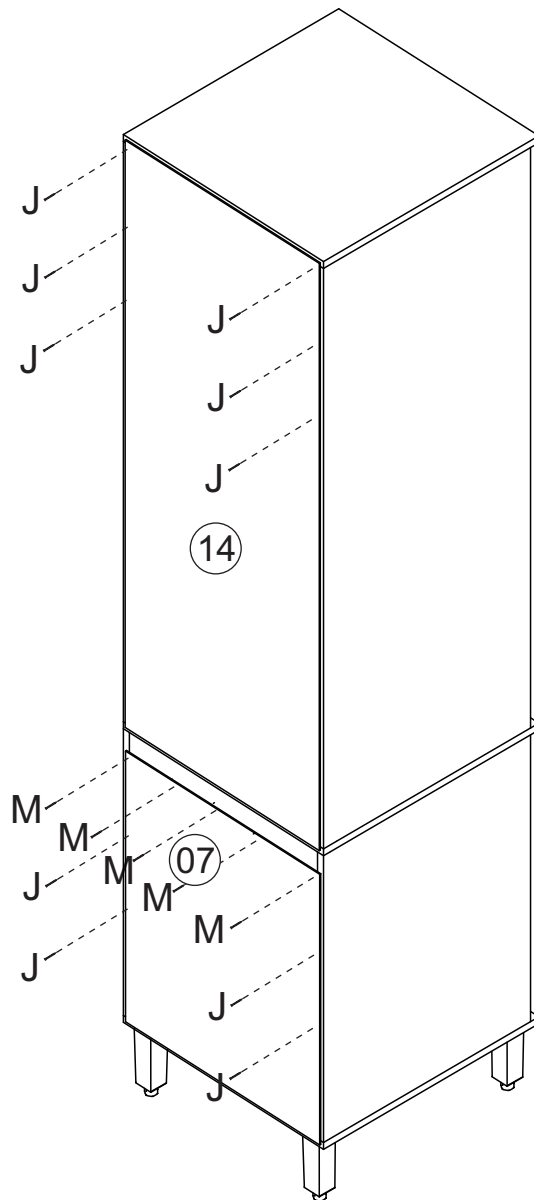

*Colocar um prego (J)
a cada 100mm.

Montagem/Montaje

07

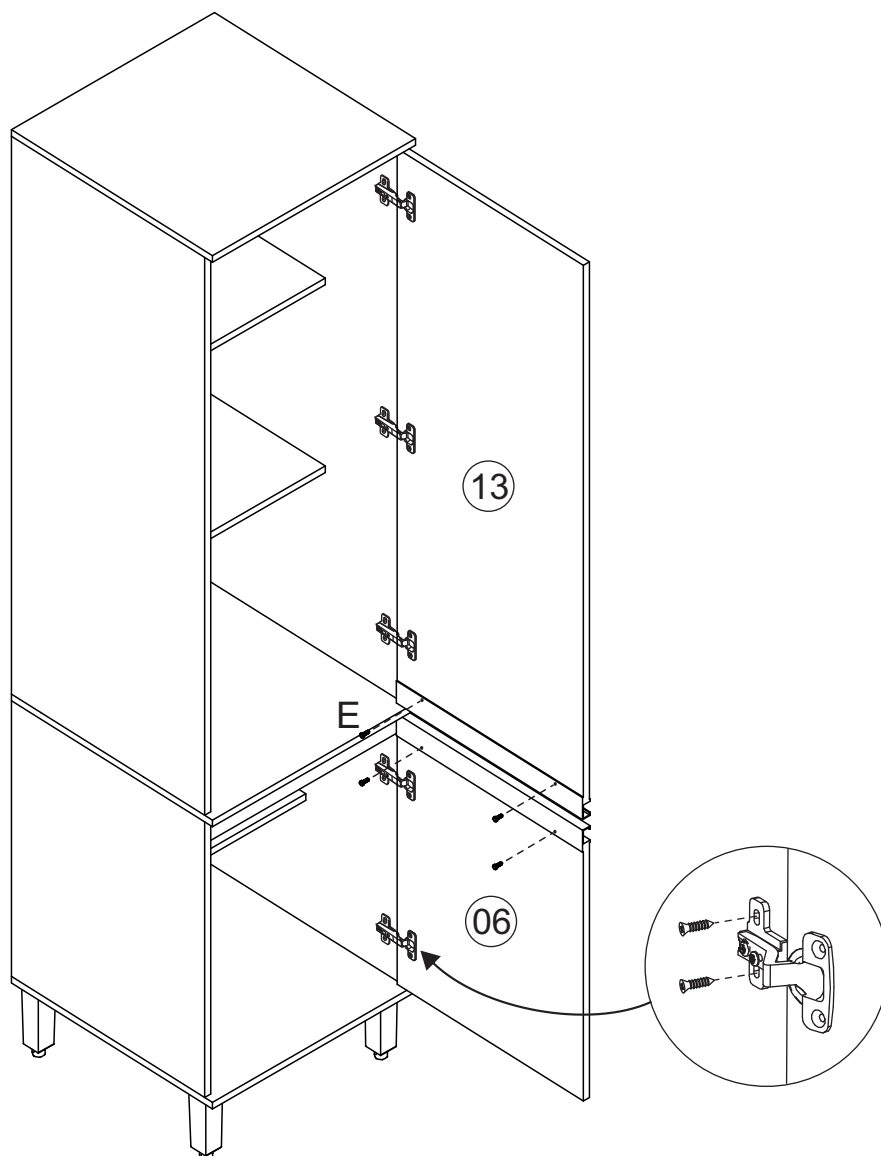

Limpeza/Limpieza

- ☞ Use um pano levemente umedecido com água, seguido de pano seco.
- ☞ Use solamente un paño húmedo con agua y después un paño seco.
- ☞ Nunca utilize produtos químicos ou abrasivos.
- ☞ No utilice productos químicos o abrasivos.