

# Mesa de Escritório / Mesa de Trabajo / Desk

## 3GAV.ESC03

### BC-5105

## MANUAL DE MONTAGEM

### INSTRUCCIONES DE ARMADO

### ASSEMBLY INSTRUCTIONS

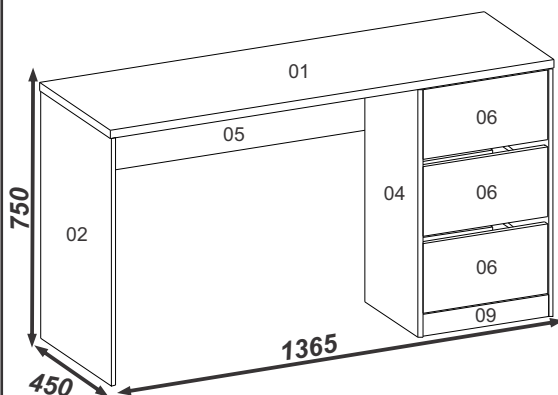

#### Ferramentas necessárias (não fornecidas)

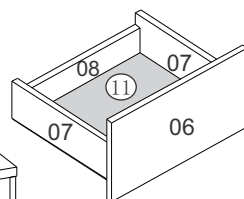
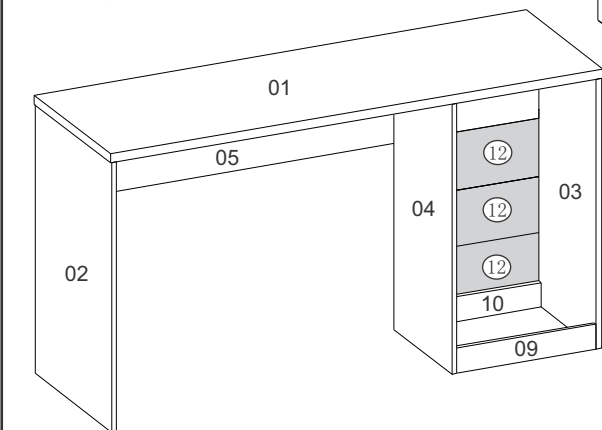
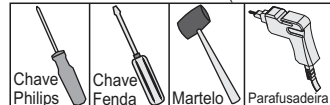

#### Ferragens/Herraje/Hardware:

330	A	Cavilhas 6 x 30 Clavija Bowel		24
0289	B	Parafuso 3,5 x 40 c/c Tornillo Screw		06
0290	C	Parafuso 3,5 x 14 c/c Tornillo Screw		42
0115	D	Parafuso minifix Tornillo Screw		10
0350	E	Tambor minifix 15 mm Minifix 15 mm Minifix 15 mm		10
0296	I	Taxa 10 x 7 Clavo 10 x 7 Nail 10 x 7		40
0477	J	Cola Pegamento Glue		01
4738	K	Cantoneira Plástica Refuerzo de plástico Plastic gusset		06
0438	L	Cantoneira Esquinera Cantoneira		09
0744	M	Taxa 13 x 15 Clavo 13 x 15 Nail 13 x 15		12
3945	O	Corrediça 300 MM Slim Rieles Slides		03
-----	P	Tapa Furo Adesivo 18mm COR 1 Pegatina Para Agujeros 18mm COLOR 1 Slap hole adesivo 18mm color 1		06
-----	Q	Sapata U 15 X 15 Pata Feet		06
0286	R	Parafuso 3,5 x 22 c/c Tornillo Screw		06

#### Dimensões Peças Prontas

#### Dimensiones de Las Piezas Prontas

#### Dimensions Ready Part

01-1363 X 450 X 25
02-723 X 448 X 15
03-723 X 448 X 15
04-723 X 337 X 15
05-1328 X 238 X 15
06-381 X 204 X 15
07-299 X 95 X 15
08-331 X 65 X 15
09-386 X 65 X 15
10-386 X 65 X 15
11-360 X 304 X 3
12-399 X 145 X 3

#### POR.

- 01-Tampo
- 02-Lateral Esquerda
- 03-Lateral Direita
- 04-Divisão
- 05-Travessa Trazeiro
- 06-Frente de Gaveta (3x)
- 07-Lateral de Gaveta (6x)
- 08-Trazeiro de Gaveta (3x)
- 09-Rodapé Frontal
- 10-Rodapé Traseiro
- 11-Fundo de Gaveta (3x)
- 12-Costas (3x)

#### ESP.

- 01-Tapa
- 02-Lateral Izquierda
- 03-Lateral Derecha
- 04-Division
- 05-Travessaño Trasero
- 06-Frente del Cajón (3x)
- 07-Lateral Del Cajón (6x)
- 08-Trasero Del Cajón (3x)
- 09-Zócalo Frontal
- 10-Zócalo Trasero
- 11-Fondo Del Cajón (3x)
- 12-Dorsos (3x)

#### ENG.

- 01-Top
- 02-Left Side
- 03-Right Side
- 04-Division
- 05-Back Crossbar
- 06-Drawer Front (3x)
- 07-Drawer Side (5x)
- 08-Drawer Back (3x)
- 09-Front Base Board
- 10-Back Base Board
- 11-Drawer Bottom (3x)
- 12-Back Panel (3x)

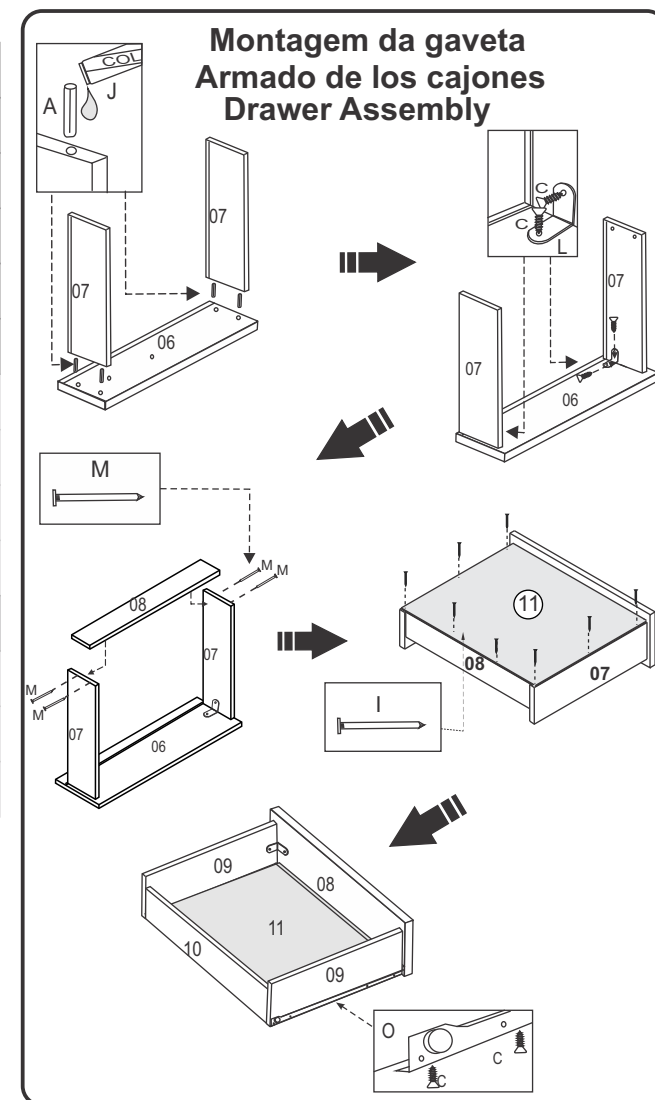

#### Instruções para a montagem do produto:

- Separe as peças e acessórios de maneira organizada.**  
Separate the parts and accessories in an organized way.  
Separe las piezas y accesorios de forma organizada

- Forrar o chão com o papelão das embalagens.**  
Cover the floor with the cardboard from the pack.  
Cubre el suelo con el cartón de los bultos.



- É necessário duas pessoas para montar o produto.**  
It's necessary two people to assembly the product.  
Se requiere dos personas para montar el producto.



medidas em mm  
measure in mm

### 1º Passo

### 1º Paso

### 1º Step

Atenção! ao parafusar a correia,  
cuidar o lado certo.

Atención! al atornillar la corredera,  
cuidar para que esté en el lado correcto

Attention! When screwing the slide,  
take care to do the right side

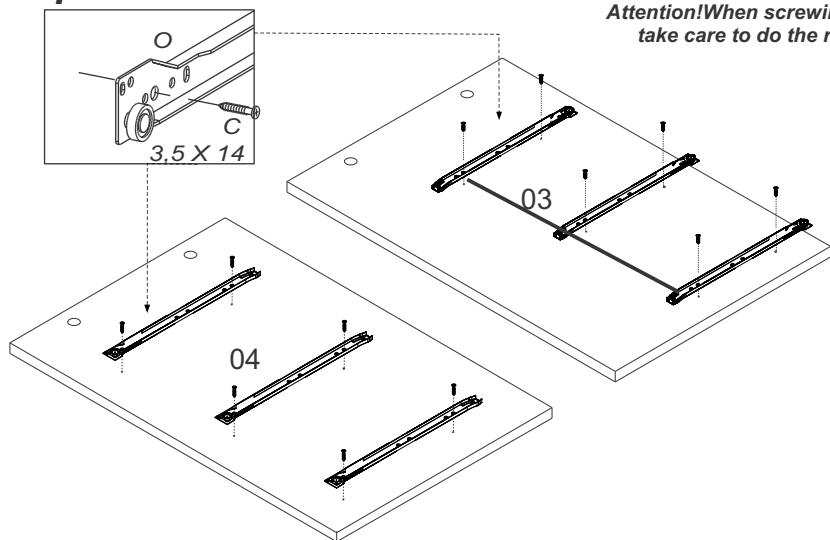

### 2º Passo

### 2º Paso

### 2º Step

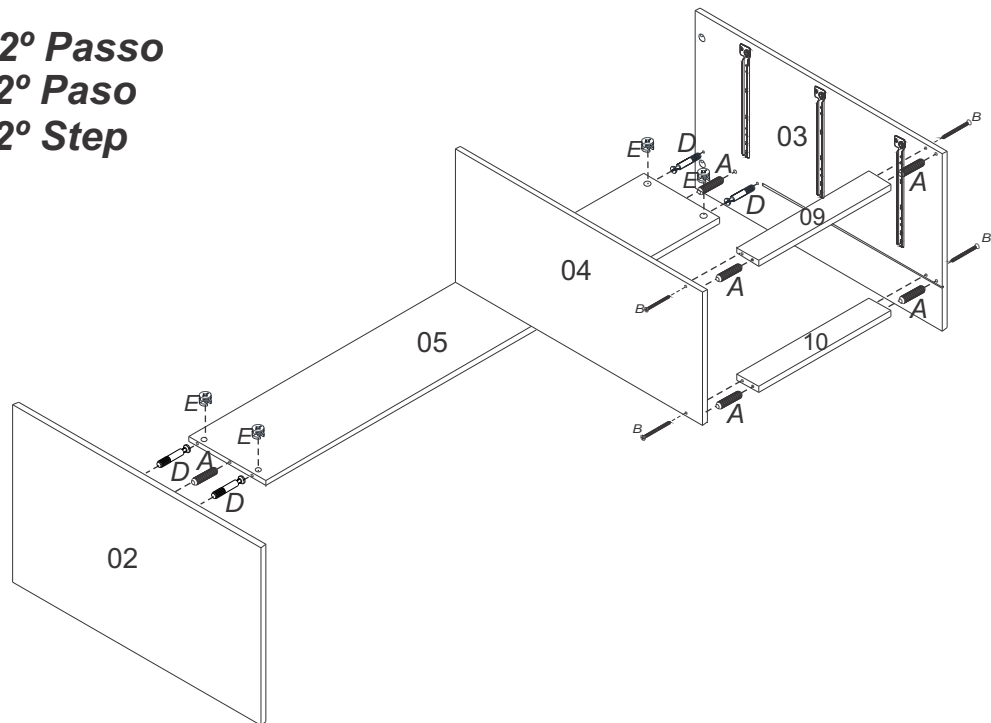

### 3º Passo

### 3º Paso

### 3º Step

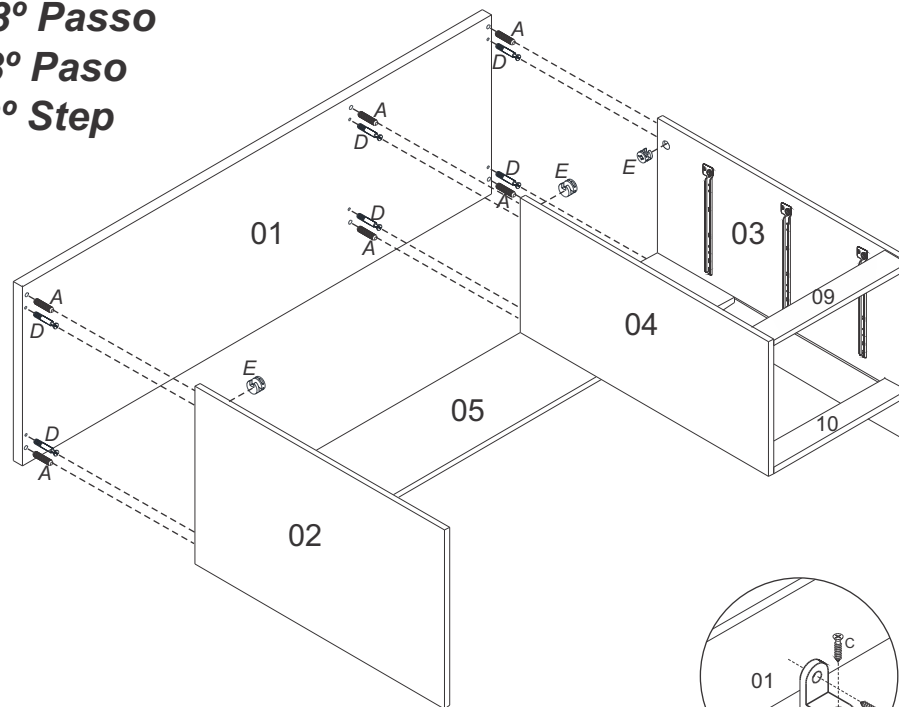

### 4º Passo

### 4º Paso

### 4º Step

Vista Traseira  
Vista Trasera  
Back View

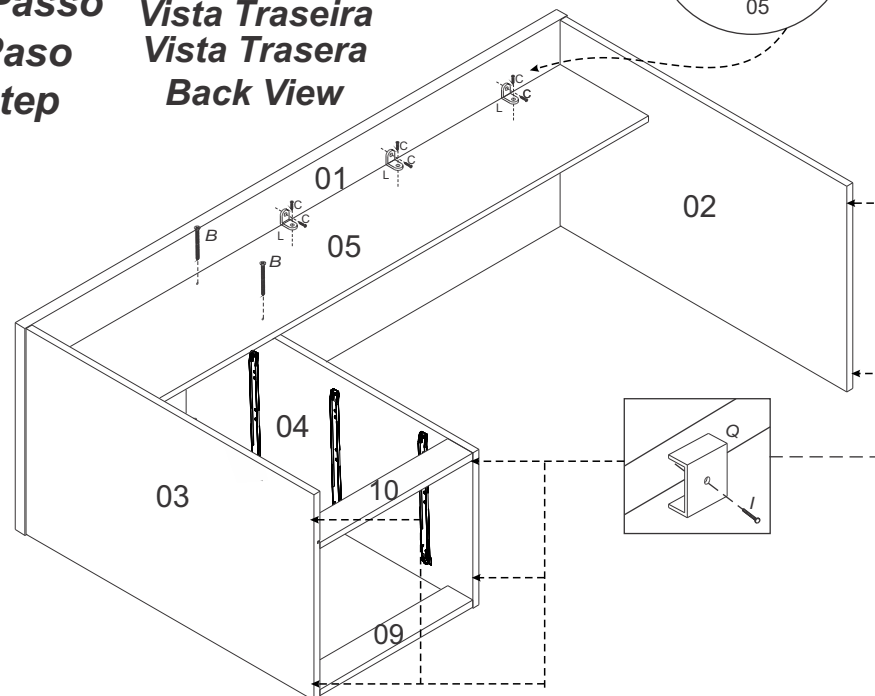

**5º Passo**

**5º Paso**

**5º Step**

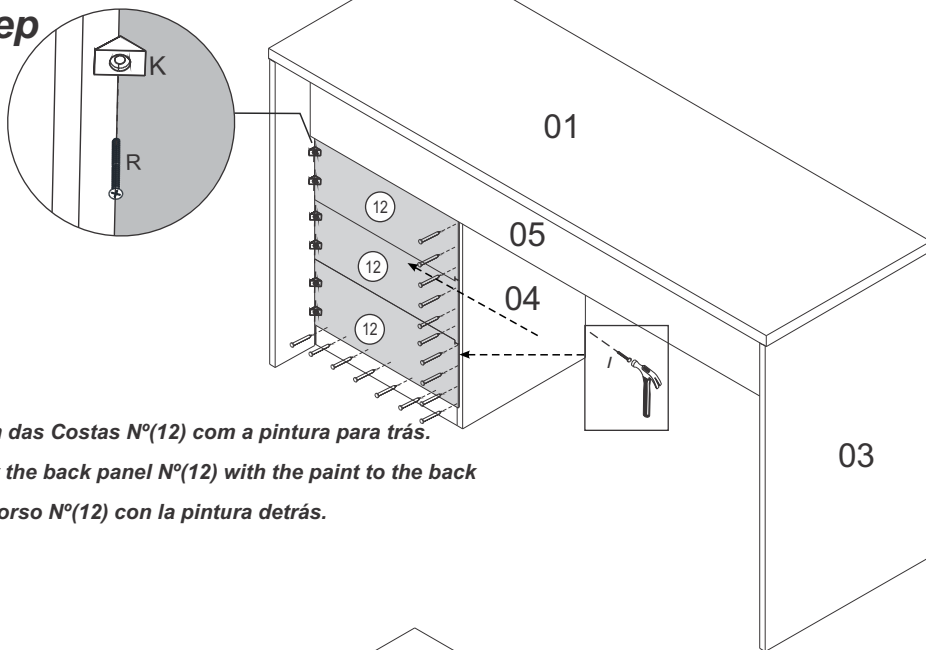

*Montagem das Costas Nº(12) com a pintura para trás.*

*Assembly the back panel Nº(12) with the paint to the back*

*Montaje dorso Nº(12) con la pintura detrás.*

**6º Passo**

**6º Paso**

**6º Step**

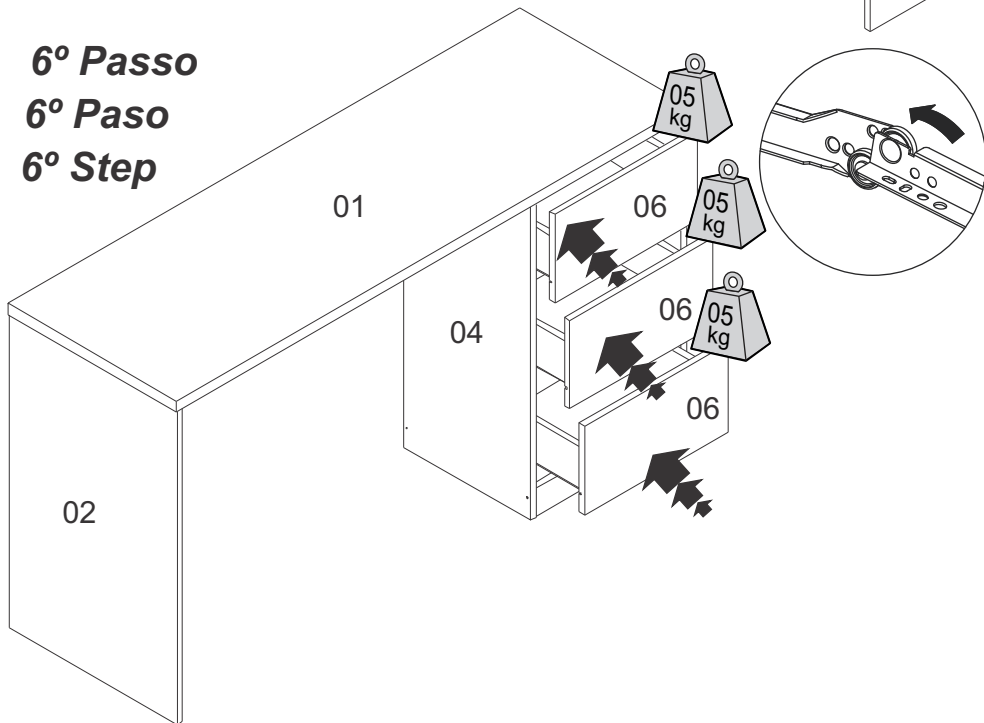

**7º Passo**

**7º Paso**

**7º Step**

