

Peça Pieze	Branco	Carvalho	Descrição	Description	Descripción	Qtd Qty	Compr Length	Larg. Width	Esp. Thickness
1	P17514	P16386	Lateral Esquerda	Left Panel	Lateral Izquierda	1	2036	436	12
2	P17515	P16389	Lateral Direita	Right Panel	Lateral Derecha	1	2036	436	12
3	P17512	P16380	Divisão Esquerda	Left Division	Division Izquierda	1	2036	468	12
4	P17513	P16385	Divisão Direita	Right Division	Division Derecha	1	2036	468	12
5	P15474	P14735	Moldura Sup. Central	Central Beam Frame	Marco suprimido	1	803	92	25
6	P15476	P14736	Moldura Sup. Menor	Smallest Sup. Frame	Marco Sup. Menor	2	505	60	25
7	P15475	P14737	Moldura Sup. Lateral	Side Superstructure	Lámpara Sup. Lateral	2	401	30	25
8	P16390	P16390	Tampo Inf Central	Top Inf Central	Tapa Inf Central	1	779	468	12
9	P16387	P16387	Tampo Sup/Inf Lat.	Sup / Inf Lateral Top	Tapa Sup / Inf Lateral	4	493	436	12
10	P16384	P16384	Tampo Intermediário	Intermediate Top	Tapa	1	779	450	12
11	P16383	P16383	Tampo (1ld s/Pintura)	Cover (One ld s/ painted)	Tapa (1ld s/ pintura)	1	779	450	12
12	P16388	P16388	Tampo Lateral	Lateral Top	Tapa lateral	8	493	436	12
13	P15473	P14727	Frete Pé Central	Front Center Foot	Frete Pie Central	1	779	72	15
14	P15472	P14726	Frete Pé Lateral	Front Side Foot	Del lado derecho	2	493	72	15
15	P16392	P16392	Frete Gaveta	Drawer Frontal	Frete del Cajón	2	723	149	12
16	P16060	P16060	Lateral Gaveta	Side Drawer	Lateral del Cajón	4	385	88	12
17	P16393	P16393	Fundo Gaveta	Bottom Drawer	Fondo del Cajón	2	704	403	2,5
18	P16391	P16391	Traseiro Gaveta	Rear Drawer	Traseiro del Cajón	2	704	88	12
19	P16381	P16381	Fundo Central	Central Fund	Fondo Central	2	1964	392	2,5
20	P16382	P16382	Fundo Lateral	Lateral Background	Fondo Lateral	4	1964	251	2,5
21	P14731	P14731	Traseiro Pé Central	Rear Center Foot	Trasero Pie Central	1	779	72	15
22	P14728	P14728	Traseiro Pé Lateral	Rear Foot	Trasero Pie Lateral	2	493	72	15
23	P17543	P17543	Tampo Sup Central	Top Sup Central	Tapa Sup Central	1	779	468	12
24	P17510	P16394	Porta Lateral	Side Door	Puerta Lateral	2	1952	495	15
25	P17511	P16395	Porta Central	Central Door	Puerta Central	2	1952	394	15

Atenção com a cor do acabamento!
Em caso de assistência solicitar o código de acordo com a cor da peça/
Pay attention to the color of the finish!
In case of assistance request the code according to the color of the part/
Atención con el color del acabado!
En caso de asistencia solicitar el código de acuerdo con el color de la pieza.

Cod. Qnt.

A 10	B 24	C 2	D 6	E 76	F 36	G 4	H 28	I 2
Parafuso Biofix 33160	Parafuso 3,5x12 CP 33297	Puxador Ponto Canaan 34530 - Cromado	Parafuso Soberbão 7x40 25691	Parafuso 4,0x12 CC 30189	Parafuso 4,0x45 CF 33292 - Zincado Amarelo 33194 - Zincado Branco	Parafuso 4,0x45 CC 33696 - Zincado Amarelo 33002 - Zincado Branco	Cavilha 6x30 24603	Parafuso 3,5x25 CF (Puxador Ponto Canaan)
J 10	K 4	L 4	M 18	N 10	O 30	P 130	Q 8	R 2
Parafuso 4,0x35 CF 29815	Parafuso 3,5x10 CC 36722 (Emb. c/ Sup. Cabideiro)	Parafuso 3,5x30 CF 25700 (Puxador Citrino)	Parafuso 3,5x14 CP 34125 - Zincado Branco	Paraf. Minifix Haste Dupla 30198	Presilha Fundo 24099	Prego 10x10 20179	Sapata Plástica 12x12 33640 - Carvalho 32278 - Branco	Sache de cola 10g 25676
S 6	T 24	U 24	V 4	W 2	X 40	Y 8	Z 16	AA 16
Tambor Minifix 15mm 22388	Tambor Minifix 12mm 30182	Tampa Tambor Minifix 36012 - Linho	Tampa Soberbão 33290 - Carvalho 27089 - Branco	Suporte Triangular 30094	Porca Cilíndrica 36008 - Linho	Cantoneira Plástica 36010 - Linho	Calço p/ Dobradilha 23273	Dobradilha Baixa 23271
AB 2	AC 1	AD 2	AE 2	AF 2	AG 2	AH 1	AI 3	AJ 2
Suporte Cabideiro 36611	Adesivo Logotipo THB 31363	Corrediza Macho Dir. 21611	Corrediza Macho Esq. 21611	Corrediza Fêmea Esq. 21611	Corrediza Fêmea Dir. 21611	Cab. Oblongo 772mm 35138	Perfil H 1964mm 34804 - Champagne	Puxador Citrino 312mm 24904 - Alumínio 28717 - Ponteira Crom.

Espelhos Splendore New Plus Glass

26	34849	Espelho Maior	DoorLarge Mirror	Espejo Mayor	2	974	350	3
27	34850	Espelho Menor	Small Mirror	Espejo Menor	4	487	350	3

Espelhos Splendore New Glass

27	30938	Espelho Maior	DoorLarge Mirror	Espejo Mayor	2	1348	350	3
----	-------	---------------	------------------	--------------	---	------	-----	---



Ferramentas necessárias (Não fornecidas)
Tools Required (Not Provided)
Herramientas necesarias (no incluidas)



Medidas em mm

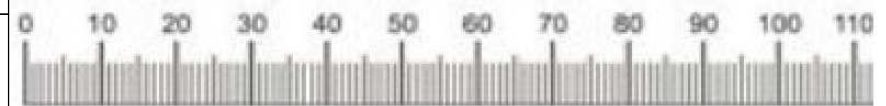

AK 8	-	-	-	-	-
Distanciador 25mm 37492					

Roupeiro Splendore New 4 Portas / Wardrobe Splendore New 4 Doors / Ropero Splendore New 4 Puertas

1º Passo / Step / Paso

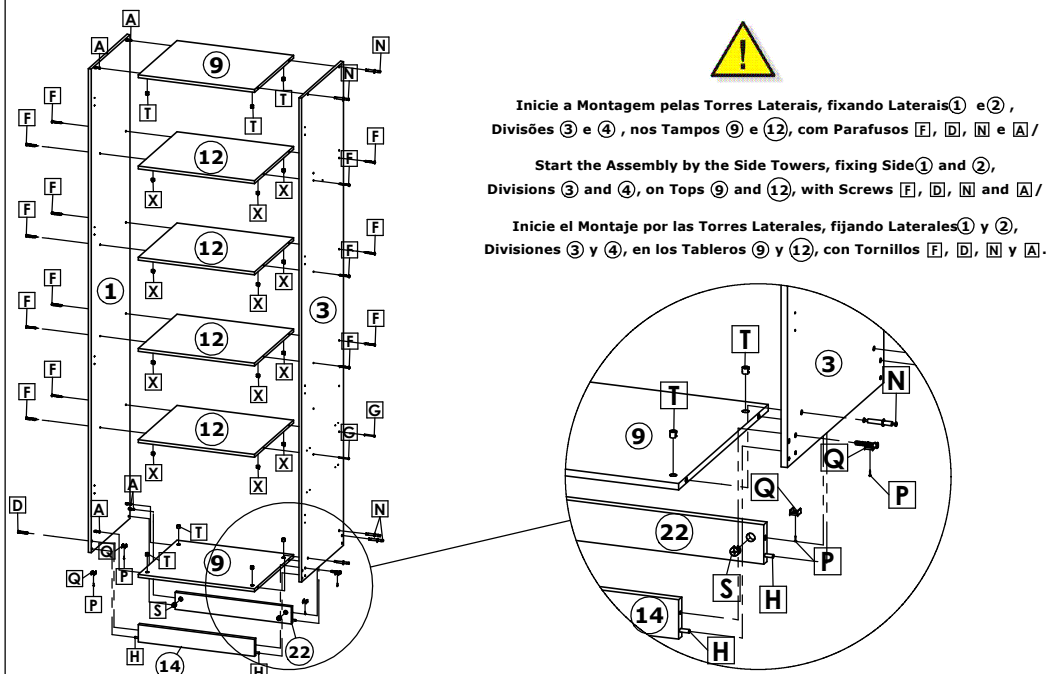

2º Passo / Step / Paso

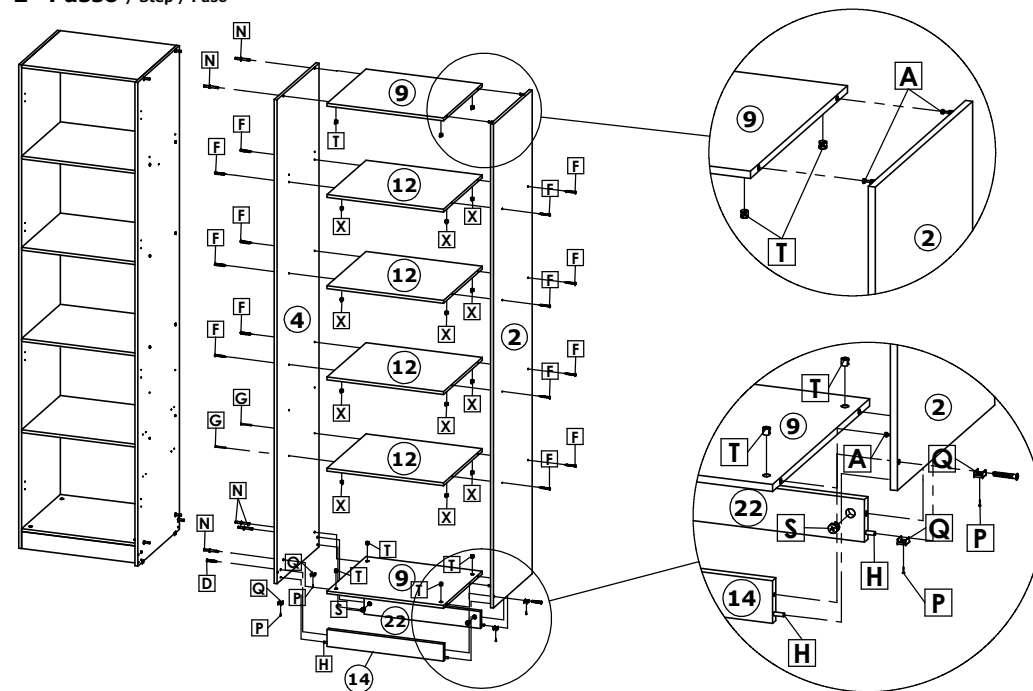

3º Passo / Step / Paso

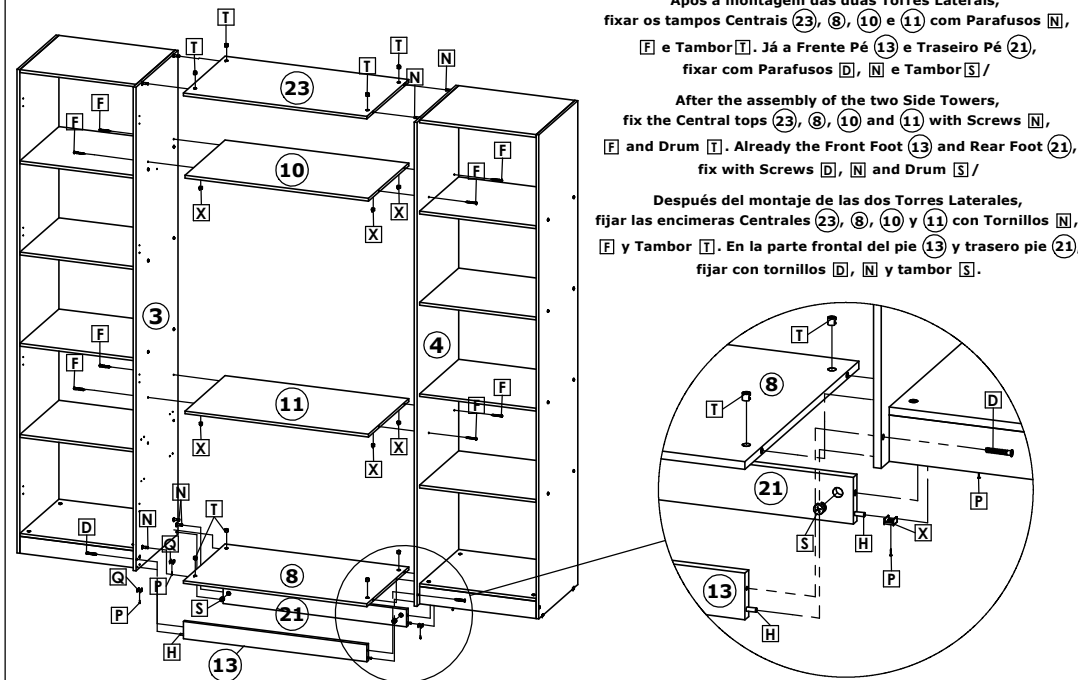

4º Passo / Step / Paso

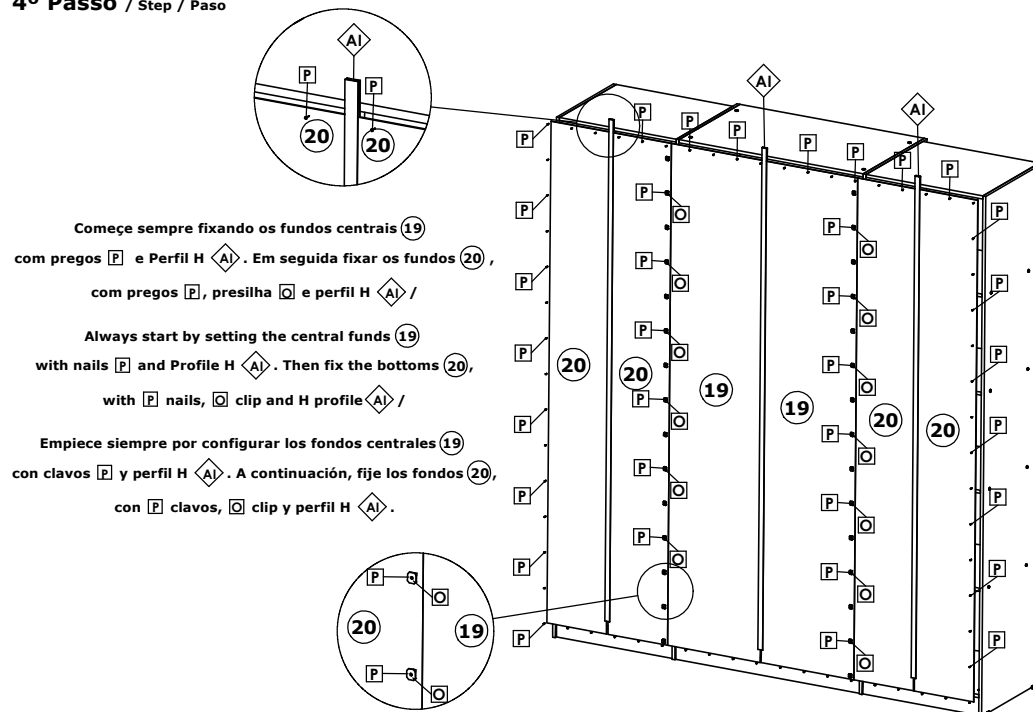

Roupeiro Splendore New 4 Portas / Wardrobe Splendore New 4 Doors / Ropero Splendore New 4 Puertas

5º Passo / Step / Paso

Após posicionar as Molduras Superior ⑤, ⑥ e ⑦, fixa-las com Parafuso J /
 After positioning the Top Frames ⑤, ⑥ and ⑦, secure them with Screw J /
 Después de colocar los Marcos Superior ⑤, ⑥ y ⑦, fijarlos con Tornillo J.

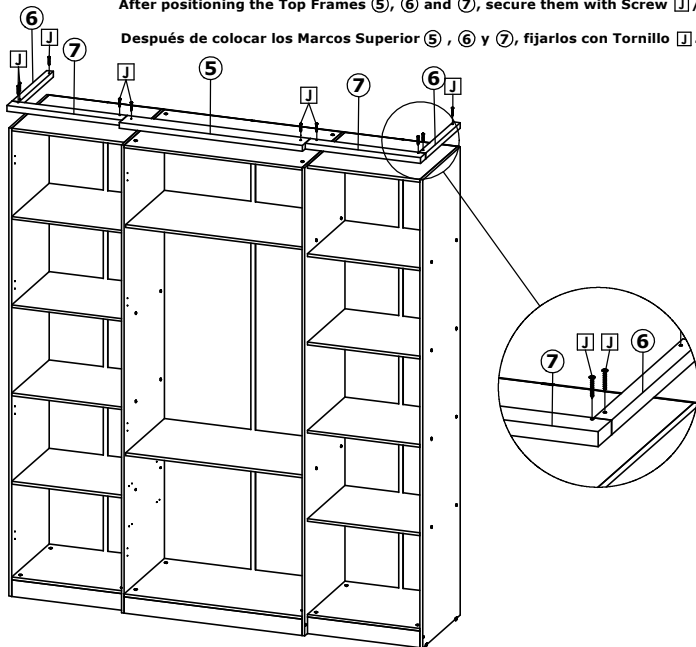

6º Passo / Step / Paso

Montagem das Gavetas / Mounting the Drawers / Montaje del Cajón.

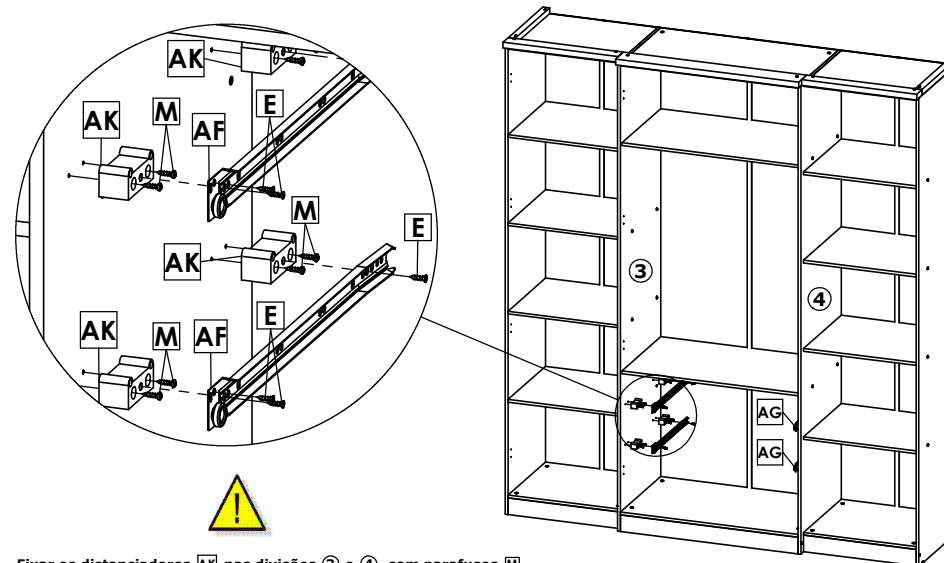
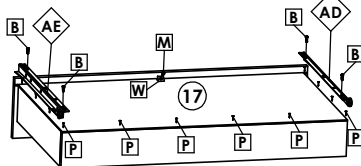
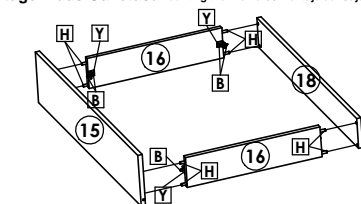

Fixar os distanciadores AK nas divisões ③ e ④, com parafusos M.
 Logo fixar as correijas AF e AG nos distanciadores AK com parafusos E /
 Fix spacers AK in divisions ③ and ④, with screws M.
 Then fix the slides AF and AG on the spacers AK with screws E /
 Fije los espaciadores AK en las divisiones ③ y ④, con tornillos M.
 Luego fije las diapositivas AF y AG en los espaciadores AK con tornillos E.

7º Passo / Step / Paso

Peso Suportado / Weight supported / peso que soporta



Fixar Suportes de Cabideiro AB, com Parafuso K nas Divisões ③ e ④ /
 Attach Clothes Rack AB with Screw K in Divisions ③ and ④ /
 Fijar Soportes de Cabelzal AB, con Tornillo K en las Divisiones ③ y ④.

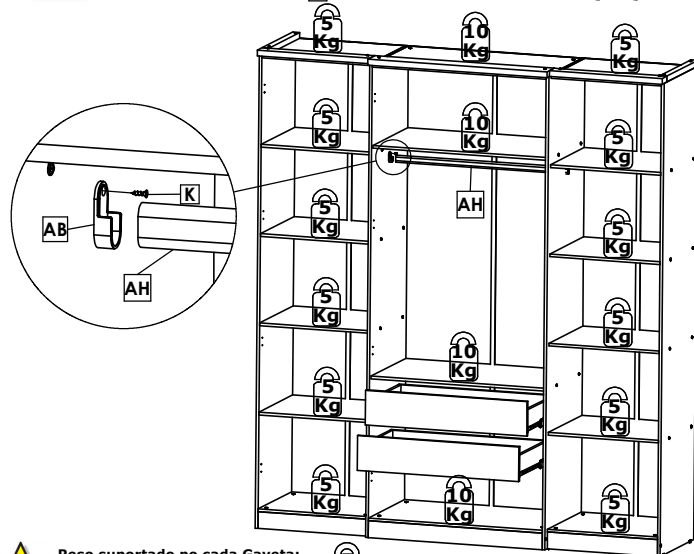

Peso suportado po cada Gaveta:
 Weight supported by each Drawer:
 Peso suportado por cada Cajón:



Montagem Portas Splendore New / Splendore New Doors / Puertas Splendore New

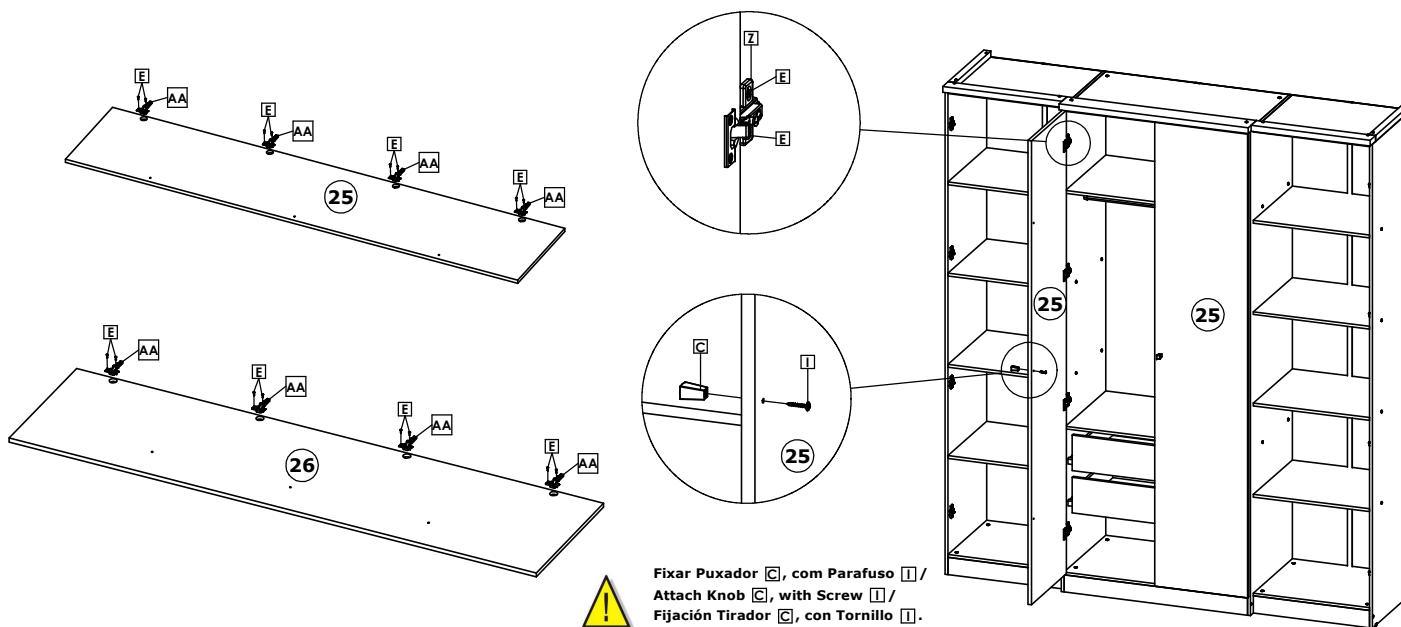

Fixar Puxador C, com Parafuso I /
 Attach Knob C, with Screw I /
 Fijación Tirador C, con Tornillo I.

Roupeiro Splendore New 4 Portas / Wardrobe Splendore New 4 Doors / Ropero Splendore New 4 Puertas

Montagem Portas Splendore New/ Splendore New Doors / Puertas Splendore New

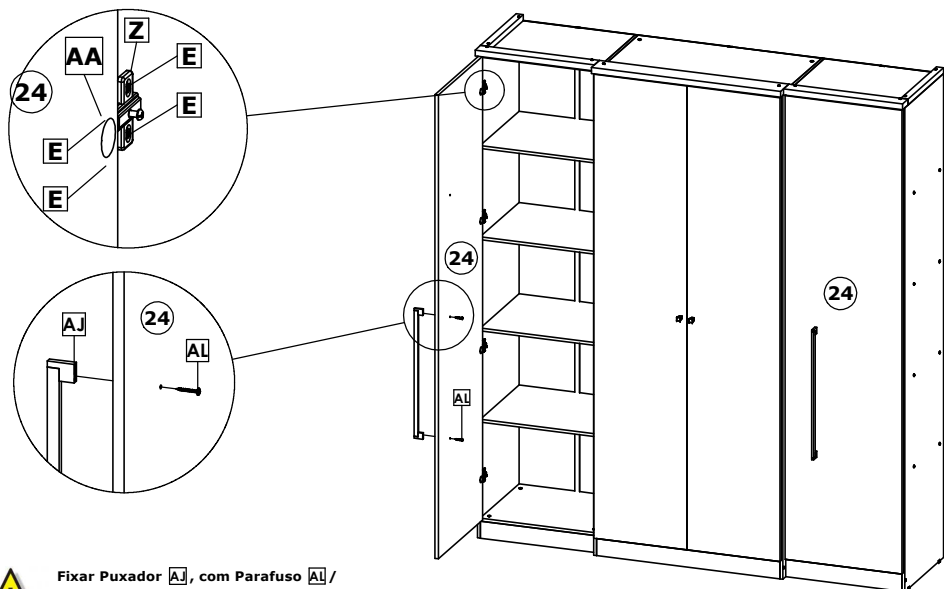

Fixar Puxador [AJ], com Parafuso [AL] /
Attach Knob [AJ], with Screw [AL] /
Fijación Tirador [AJ], con Tornillo [AL].

Inicie a montagem alinhando os Espelhos Superior (27), com a Lateral e topo da Porta (25).

Logo inserir os Espelhos (26) e (27), fixando-os com Parafusos [AM] e Suporte Vidro Pino [AL], deixando entre cada Espelho um espaçamento de 2mm /
Start the assembly by aligning the Top (27), Mirrors with the Side and Top of Door (25).
Then insert Mirrors (26) and (27), securing them with Screws [AM] and Glass Pin Support [AL], leaving between each Mirror a spacing of 2mm /

Inicie el montaje alineando los espejos (27) superior, con el lateral y la parte superior de la puerta (25).

Luego inserte los Espejos (26) y (27), fijándolos con Tornillos [AM] y Soporte Vidro Pino [AL], dejando entre cada espejo un espaciamento de 2mm.

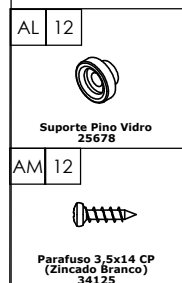
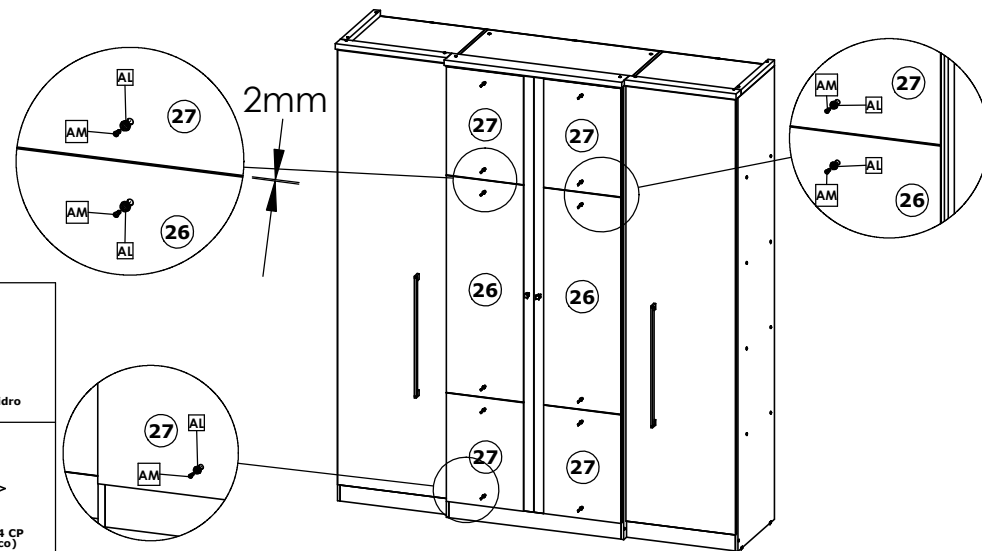

Posicione os Espelhos (26), á 302mm do Topo da Porta (25) e paralelo a lateral da Porta (25).

Logo fixe os Espelhos (26), com Parafusos [AN] e Suporte Vidro Pino [AM] /

Position Mirrors (26), 302mm from Top of Door (25) and parallel to side of Door (25).

Then secure the Mirrors (26), with Screws [AN] and Mount Glass Pin [AM] /

Coloque los espejos (26), a 302mm de la parte superior de la puerta (25) y paralelo al lateral de la puerta (25).

Luego fije los Espejos (26), con Tornillos [AN] y Soporte Vidro Pino [AM].

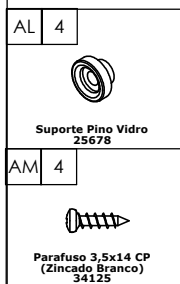
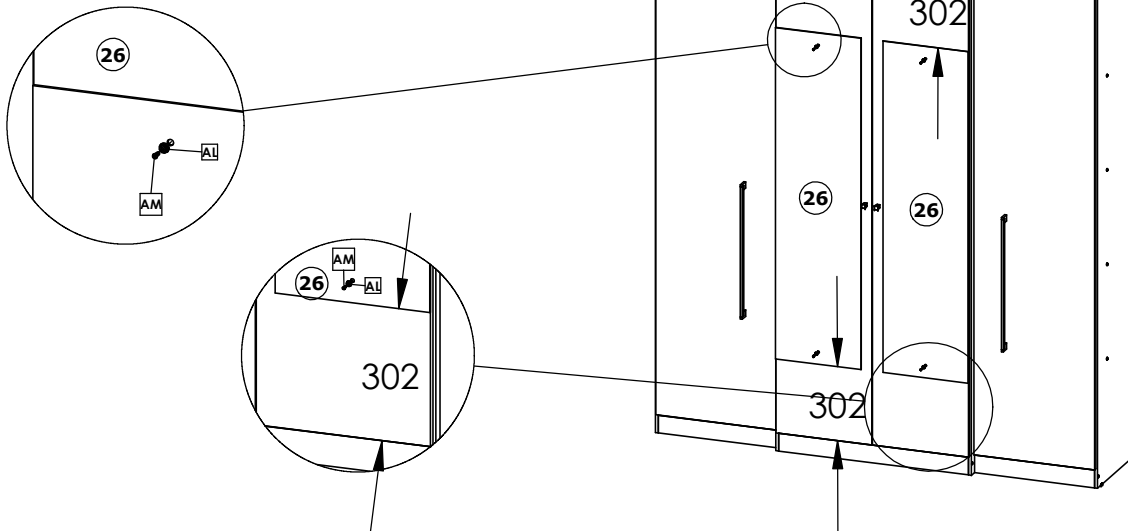

Splendore New

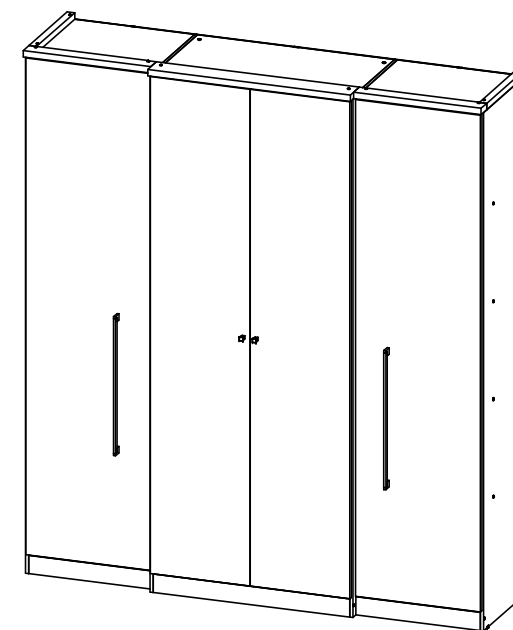

Splendore New Glass

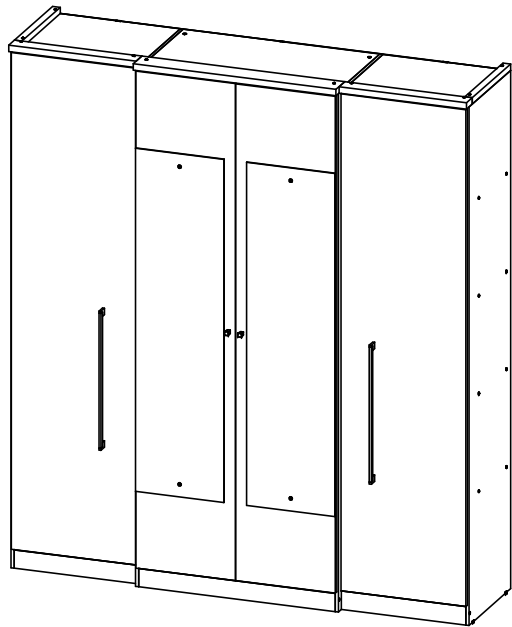

Splendore New

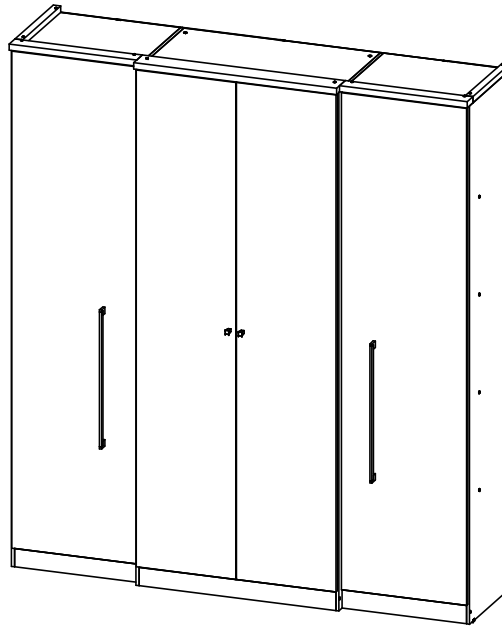

Splendore New Glass

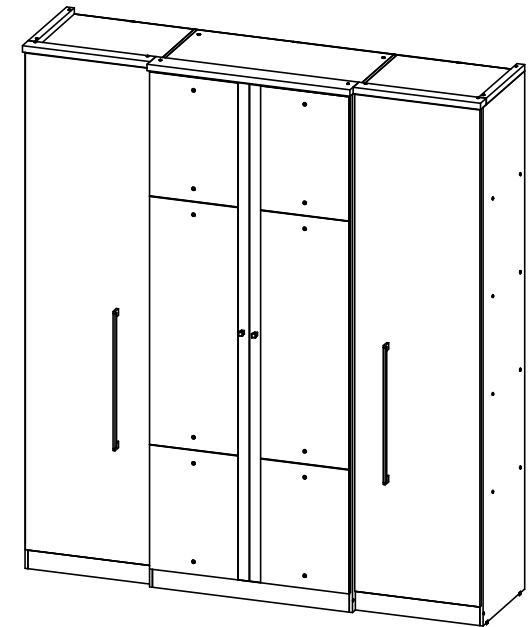

Montagem Pés Splendore New/ Mounting Feet Splendore New/ Montaje Pies Splendore New.

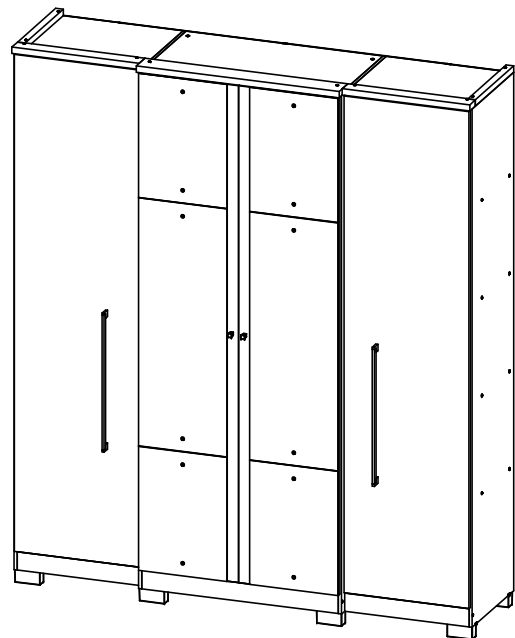

Os Pés são opcionais e podem ou não acompanhar o produto, depende da versão que você está adquirindo/
 Feet are optional and may or may not accompany the product, depending on the version you are purchasing/
 Los Pies son opcionales y pueden o no acompañar el producto, depende de la versión que usted está adquiriendo.

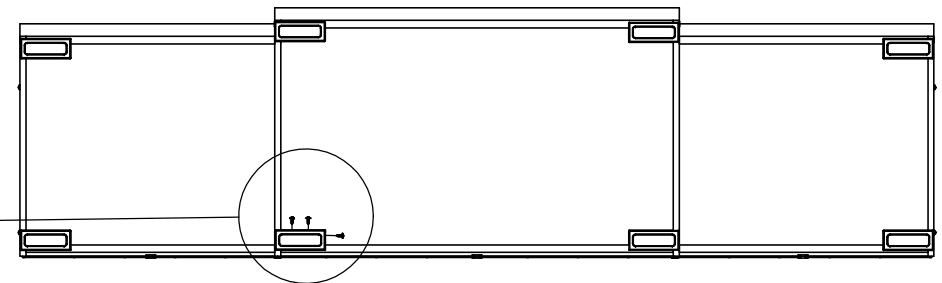
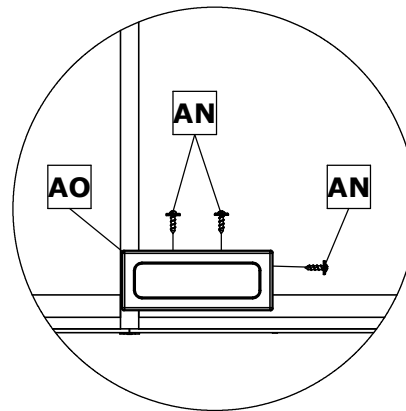

Na opção com Pés, fixar pés AO com Parafusos AN /
 In the option with Feet, fix feet AO with Screws AN /
 Na opção com Pés, fixar pés AO com Parafusos AN .

AN 24



Parafuso 4.0x12 CF 30518

AO 8



Pé Retangular 34700



Roupeiro Splendore New 4 Portas / Wardrobe Splendore New 4 Doors / Ropero Splendore New 4 Puertas

quarta-feira, 22 de junho de 2022

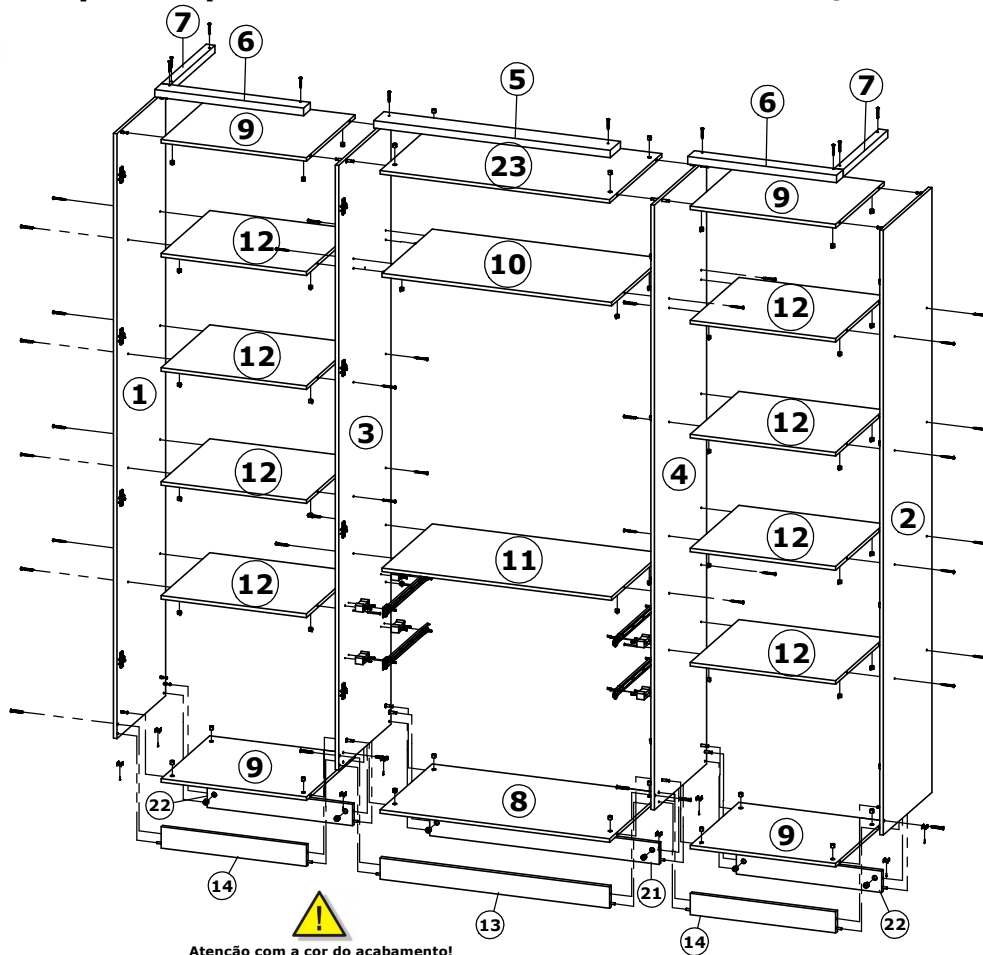

Peça Pieça	Preto Stv	Descrição	Description	Descripción	Qtd Qty Cant	Compr Length Largo	Larg. Width Ancho	Esp. Thickness Espesor
1	P19083	Lateral Esquerda	Left Panel	Lateral Izquierda	1	2036	436	12
2	P19085	Lateral Direita	Right Panel	Lateral Derecha	1	2036	436	12
3	P19077	Divisão Esquerda	Left Division	Division Izquierda	1	2036	468	12
4	P19082	Divisão Direita	Right Division	Division Derecha	1	2036	468	12
5	P19079	Moldura Sup. Central	Central Beam Frame	Marco suprimido	1	803	92	25
6	P19081	Moldura Sup. Menor	Smallest Sup. Frame	Marco Sup. Menor	2	505	60	25
7	P19080	Moldura Sup. Lateral	Side Superstructure	Lámpara Sup. Lateral	2	401	30	25
8	P16390	Tampo Inf Central	Top Inf Central	Tapa Inf Central	1	779	468	12
9	P16387	Tampo Sup/Inf Lat.	Sup / Inf Lateral Top	Tapa Sup / Inf Lateral	4	493	436	12
10	P16384	Tampo Intermediário	Intermediate Top	Tapa	1	779	450	12
11	P16383	Tampo (1ld s/Pintura)	Cover (One ld painted)	Tapa (1ld s/ pintura)	1	779	450	12
12	P16388	Tampo Lateral	Lateral Top	Tapa lateral	8	493	436	12
13	P19078	Frente Pé Central	Front Center Foot	Frente Pie Central	1	779	72	15
14	P19084	Frente Pé Lateral	Front Side Foot	Del lado derecho	2	493	72	15
15	P16392	Frente Gaveta	Drawer Frontal	Frente del Cajón	2	723	149	12
16	P16060	Lateral Gaveta	Side Drawer	Lateral del Cajón	4	385	88	12
17	P16393	Fundo Gaveta	Bottom Drawer	Fondo del Cajón	2	704	403	2,5
18	P16391	Traseiro Gaveta	Rear Drawer	Traseo del Cajón	2	704	88	12
19	P16381	Fundo Central	Central Fund	Fondo Central	2	1964	392	2,5
20	P16382	Fundo Lateral	Lateral Background	Fondo Lateral	4	1964	249	2,5
21	P14731	Traseiro Pé Central	Rear Center Foot	Trasero Pie Central	1	779	72	15
22	P14728	Traseiro Pé Lateral	Rear Foot	Trasero Pie Lateral	2	493	72	15
23	P17543	Tampo Sup Central	Top Sup Central	Tapa Sup Central	1	779	468	12
24	P19075	Porta Lateral	Side Door	Puerta Lateral	2	1952	495	15
25	P19076	Porta Central	Central Door	Puerta Central	2	1952	394	15



Atenção com a cor do acabamento!
Em caso de assistência solicitar o código de acordo com a cor da peça/
Pay attention to the color of the finish!
In case of assistance request the code according to the color of the part/
Atención con el color del acabado!
En caso de asistencia solicitar el código de acuerdo con el color de la pieza.

Cod. Qnt.

A 10 Parafuso Bifix 33160	B 24 Parafuso 3,5x12 CP 33297	C 2 Puxador Ponto Canaan 34530 - Cromado	D 6 Parafuso Soberbão 7x40 25691	E 76 Parafuso 4,0x12 CC 30189	F 36 Parafuso 4,0x50 CF 32048 - Zincado Preto	G 4 Parafuso 4,0x50 CC 32977 - Zincado Preto	H 28 Cavilha 6x30 24603	I 2 Parafuso 3,5x25 CF 24648 (Puxador Ponto Canaan)
J 10 Parafuso 4,0x35 CF 29815	K 4 Parafuso 3,5x30 CC 36722 (Emb. c/ Sup. Cabideiro)	L 4 Parafuso 3,5x30 CF 25700 (Puxador Citrino)	M 18 Parafuso 3,5x14 CP 34125 - Zincado Branco	N 10 Paraf. Minifix Haste Dupla 30198	O 30 Presilha Fundo 24099	P 130 Prego 10x10 20179	Q 8 Sapata Plástica 12x12 38762 - Preto	R 2 SACHE de cola 10g 25676
S 6 Tambor Minifix 15mm 22388	T 24 Tambor Minifix 12mm 30182	U 24 Tampa Tambor Minifix 36012 - Linho	V 4 Tampa Soberbão 38763 - Preto	W 2 Suporte Triangular 30094	X 40 Porca Cilíndrica 36008 - Linho	Y 8 Cantoneira Plástica 36010 - Linho	Z 16 Calço p/ Dobradilha 23273	AA 16 Dobradilha Baixa 23271
AB 2 Suporte Cabideiro 36611	AC 1 Adesivo Logotipo THB 31363	AD 2 Correção Macho Dir. 21611	AE 2 Correção Macho Esq. 21611	AF 2 Correção Fêmea Esq. 21611	AG 2 Correção Fêmea Dir. 21611	AH 1 Cab. Oblongo 772mm 35138	AI 3 Perfil H 1964mm 34804 - Champagne	AJ 2 Puxador Citrino 512mm 24904 - Alumínio 28717 - Ponteira Crom.
AK 8 Distancerador 25mm 37492	-	-	-	-	-	-	-	-

Espelhos Splendore New Plus Glass

26	34849	Espelho Maior	DoorLarge Mirror	Espejo Mayor	2	974	350	3
27	34850	Espelho Menor	Small Mirror	Espejo Menor	4	487	350	3

Espelhos Splendore New Glass

27	30938	Espelho Maior	DoorLarge Mirror	Espejo Mayor	2	1348	350	3
----	-------	---------------	------------------	--------------	---	------	-----	---



Ferramentas necessárias (Não fornecidas)
Tools Required (Not Provided)
Herramientas necesarias (no incluidas)



Medidas em mm



AK 8 Distancerador 25mm 37492	-	-	-	-	-	-	-
------------------------------------	---	---	---	---	---	---	---

Roupeiro Splendore New 4 Portas / Wardrobe Splendore New 4 Doors / Ropero Splendore New 4 Puertas

1º Passo / Step / Paso

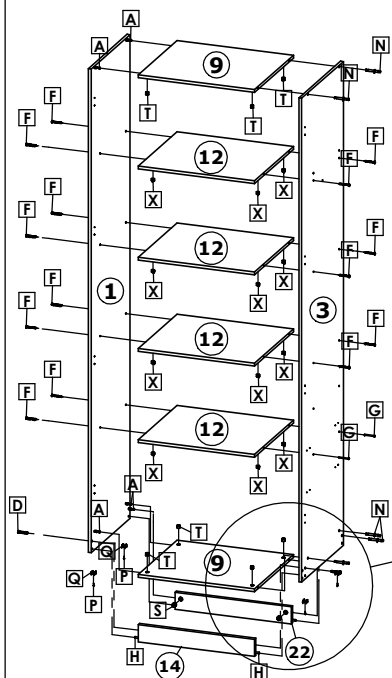

Inicie a Montagem pelas Torres Laterais, fixando Laterais ① e ②, Divisões ③ e ④, nos Tornos ⑨ e ⑫, com Parafusos F, D, N e A/

Start the Assembly by the Side Towers, fixing Side ① and ②, Divisions ③ and ④, on Tops ⑨ and ⑫, with Screws F, D, N and A/

Inicie el Montaje por las Torres Laterales, fijando Laterales ① y ②, Divisiones ③ y ④, en los Tableros ⑨ y ⑫, con Tornillos F, D, N y A/

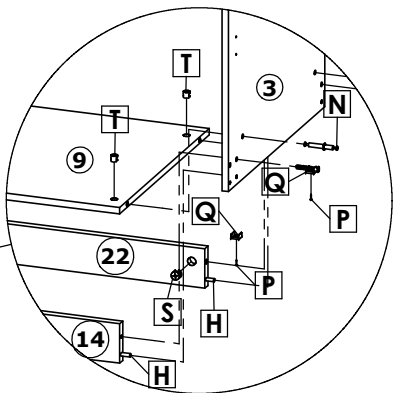

2º Passo / Step / Paso

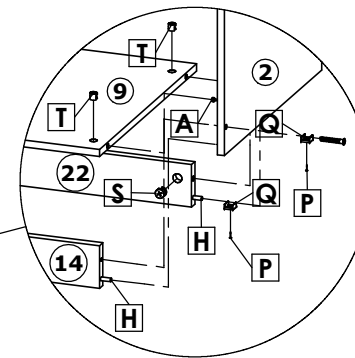
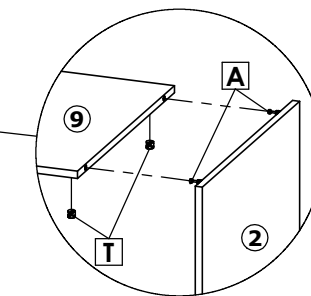
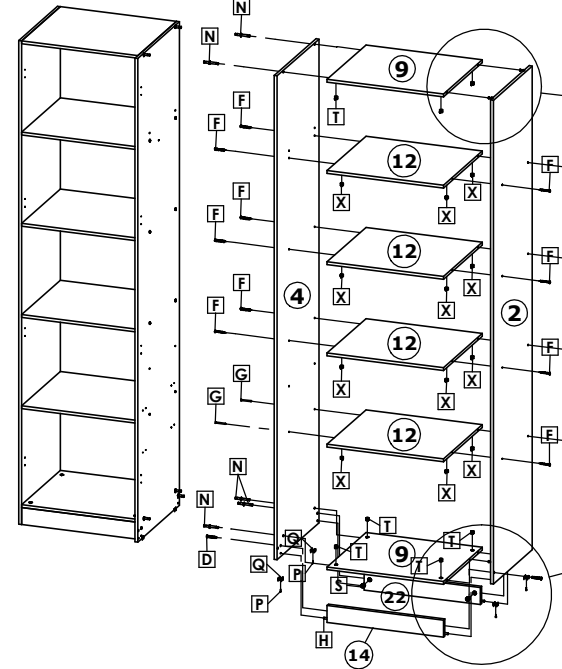

3º Passo / Step / Paso

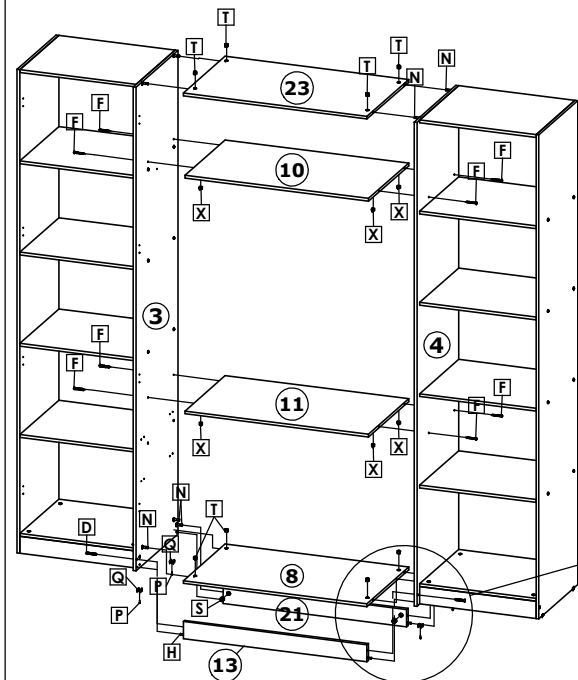

Após a montagem das duas Torres Laterais, fixar os tornos Centrais ⑫, ⑧, ⑩ e ⑪ com Parafusos N, F e Tambor T. Já a Frente Pé ⑬ e Traseiro Pé ⑮, fixar com Parafusos D, N e Tambor S/

After the assembly of the two Side Towers, fix the Central tops ⑫, ⑧, ⑩ and ⑪ with Screws N, F and Drum T. Already the Front Foot ⑬ and Rear Foot ⑮, fix with Screws D, N and Drum S/

Después del montaje de las dos Torres Laterales, fijar las encimeras Centrales ⑫, ⑧, ⑩ y ⑪ con Tornillos N, F y Tambor T. En la parte frontal del pie ⑬ y trasero pie ⑮, fijar con tornillos D, N y tambor S/

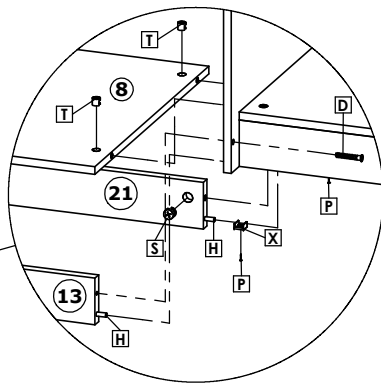

4º Passo / Step / Paso

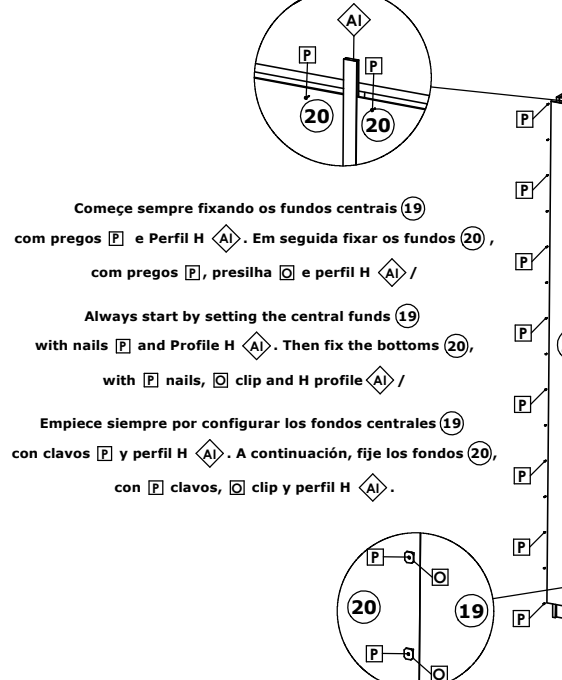

Comece sempre fixando os fundos centrais ⑮ com pregos P e Perfil H A. Em seguida fixar os fundos ⑯, com pregos P, presilha Q e perfil H A/

Always start by setting the central funds ⑮ with nails P and Profile H A. Then fix the bottoms ⑯, with P nails, Q clip and H profile A/

Empiece siempre por configurar los fondos centrales ⑮ con clavos P y perfil H A. A continuación, fije los fondos ⑯, con P clavos, Q clip y perfil H A/

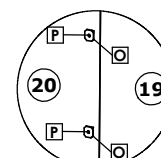
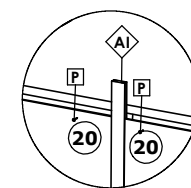

Roupeiro Splendore New 4 Portas / Wardrobe Splendore New 4 Doors / Ropero Splendore New 4 Puertas

5º Passo / Step / Paso

Após posicionar as Molduras Superior ⑤, ⑥ e ⑦, fixa-las com Parafuso J /
 After positioning the Top Frames ⑤, ⑥ and ⑦, secure them with Screw J /
 Después de colocar los Marcos Superior ⑤, ⑥ y ⑦, fijarlos con Tornillo J.

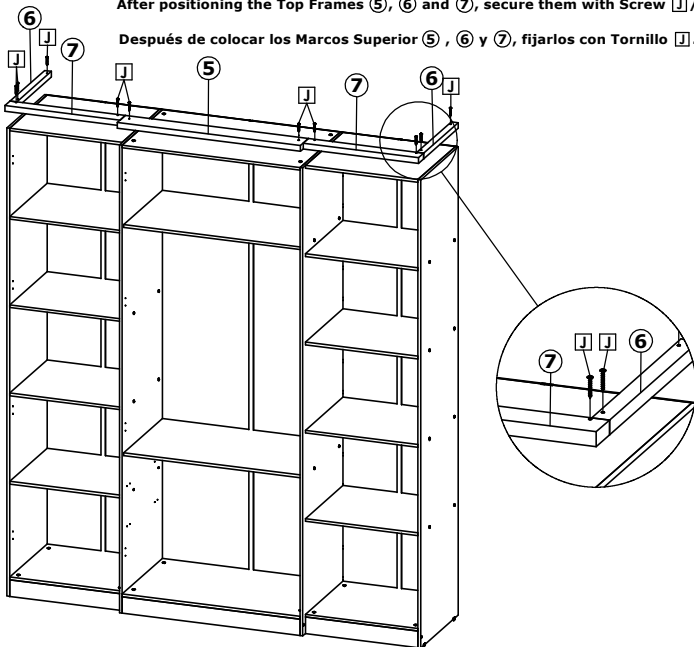

6º Passo / Step / Paso

Montagem das Gavetas / Mounting the Drawers / Montaje del Cajón.

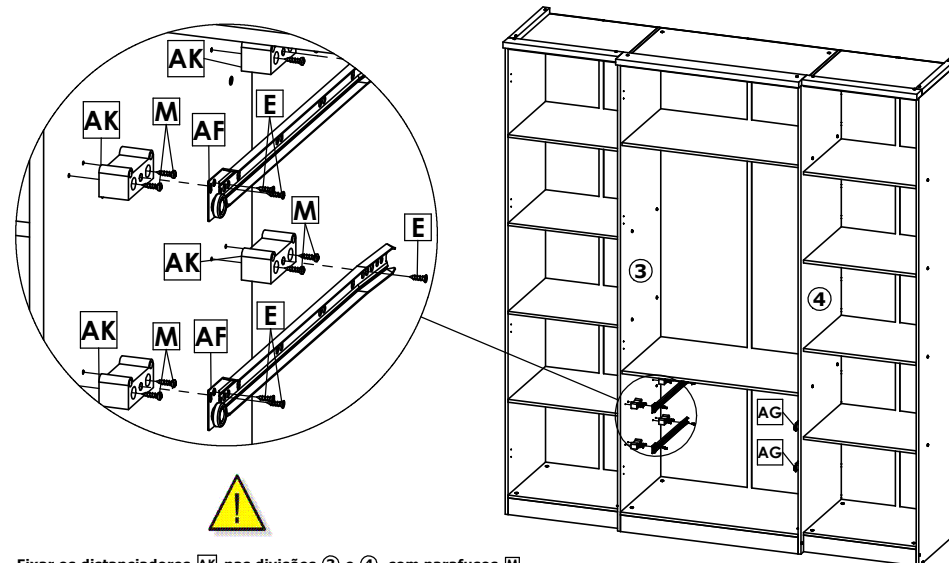
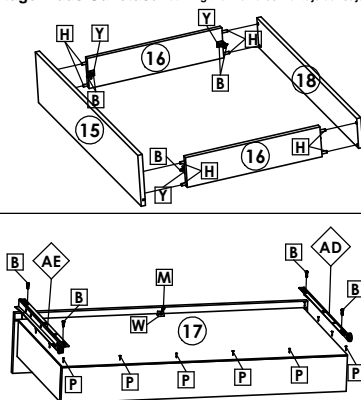

Fixar os distanciadores AK nas divisões ③ e ④, com parafusos M.
 Logo fixar as correijas AF e AG nos distanciadores AK com parafusos E /
 Fix spacers AK in divisions ③ and ④, with screws M.
 Then fix the slides AF and AG on the spacers AK with screws E /
 Fije los espaciadores AK en las divisiones ③ y ④, con tornillos M.
 Luego fije las diapositivas AF y AG en los espaciadores AK con tornillos E.

7º Passo / Step / Paso

Peso Suportado / Weight supported / peso que soporta



Fixar Suportes de Cabideiro AB, com Parafuso K nas Divisões ③ e ④ /
 Attach Clothes Rack AB with Screw K in Divisions ③ and ④ /
 Fijar Soportes de Cabezal AB, con Tornillo K en las Divisiones ③ y ④.

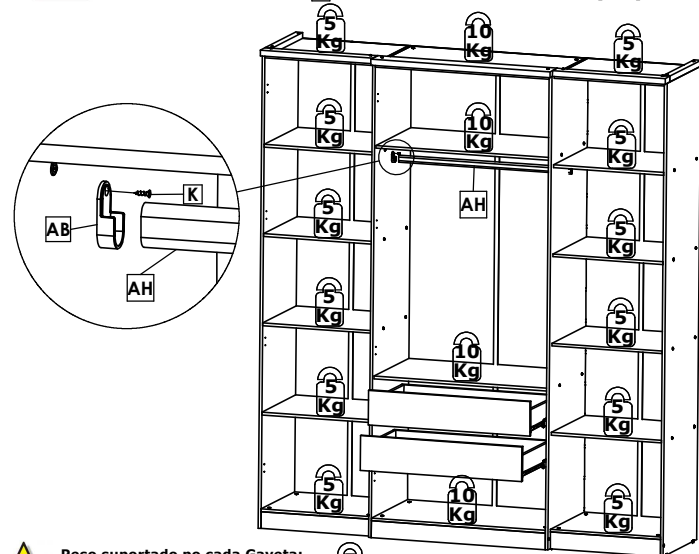

Peso suportado po cada Gaveta:
 Weight supported by each Drawer:
 Peso suportado por cada Cajón:



Montagem Portas Splendore New / Splendore New Doors / Puertas Splendore New

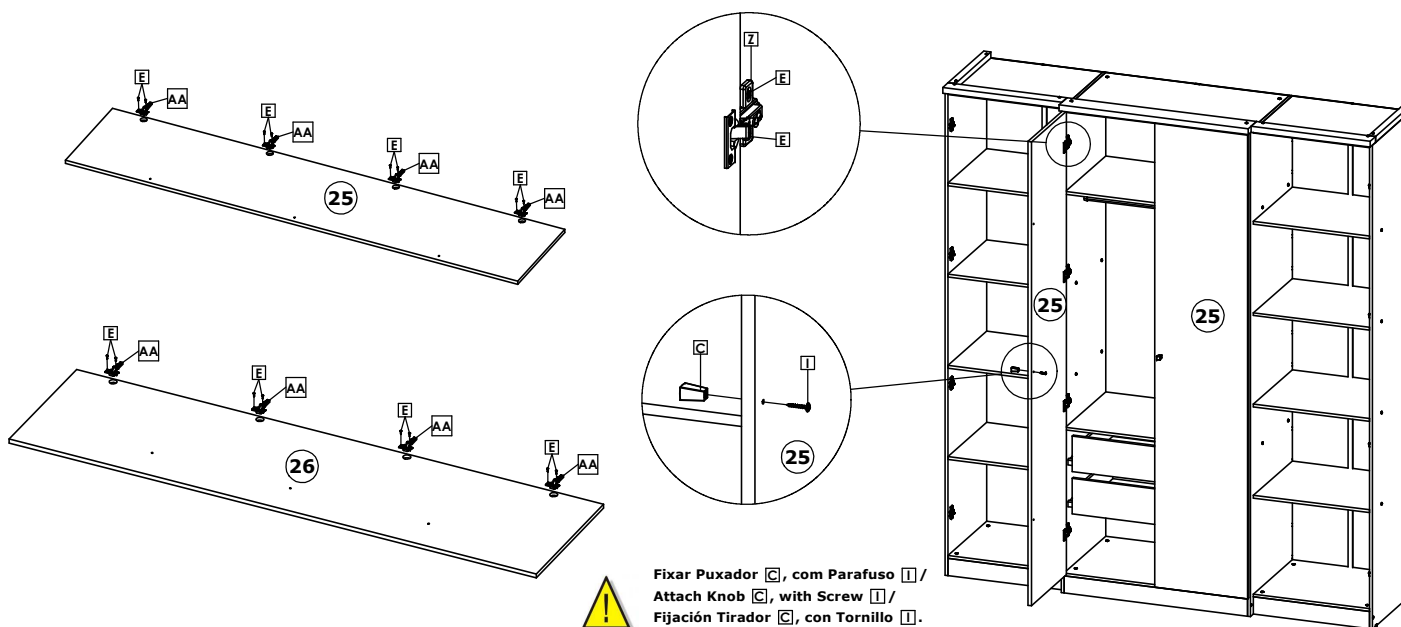

Fixar Puxador C, com Parafuso I /
 Attach Knob C, with Screw I /
 Fijación Tirador C, con Tornillo I.

Roupeiro Splendore New 4 Portas / Wardrobe Splendore New 4 Doors / Ropero Splendore New 4 Puertas

Montagem Portas Splendore New/ Splendore New Doors / Puertas Splendore New

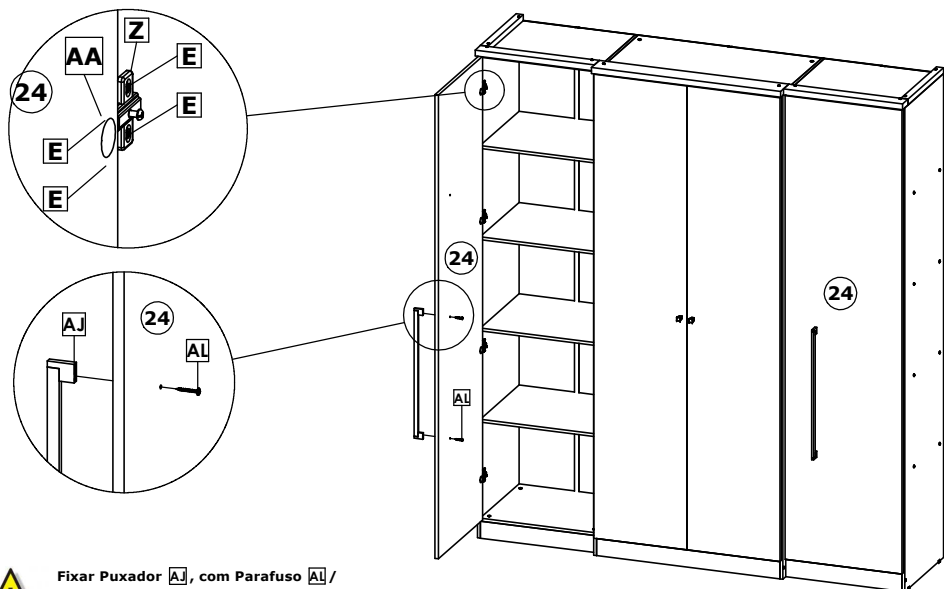

Fixar Puxador [AJ], com Parafuso [AL] /
Attach Knob [AJ], with Screw [AL] /
Fijación Tirador [AJ], con Tornillo [AL].

Inicie a montagem alinhando os Espelhos Superior (27), com a Lateral e topo da Porta (25).

Logo inserir os Espelhos (26) e (27), fixando-os com Parafusos [AM] e Suporte Vidro Pino [AL], deixando entre cada Espelho um espaçamento de 2mm /
Start the assembly by aligning the Top (27), Mirrors with the Side and Top of Door (25).

Then insert Mirrors (26) and (27), securing them with Screws [AM] and Glass Pin Support [AL], leaving between each Mirror a spacing of 2mm /

Inicie el montaje alineando los espejos (27) superior, con el lateral y la parte superior de la puerta (25).

Luego inserte los Espejos (26) y (27), fijándolos con Tornillos [AM] y Soporte Vidro Pino [AL], dejando entre cada espejo un espaciamento de 2mm.

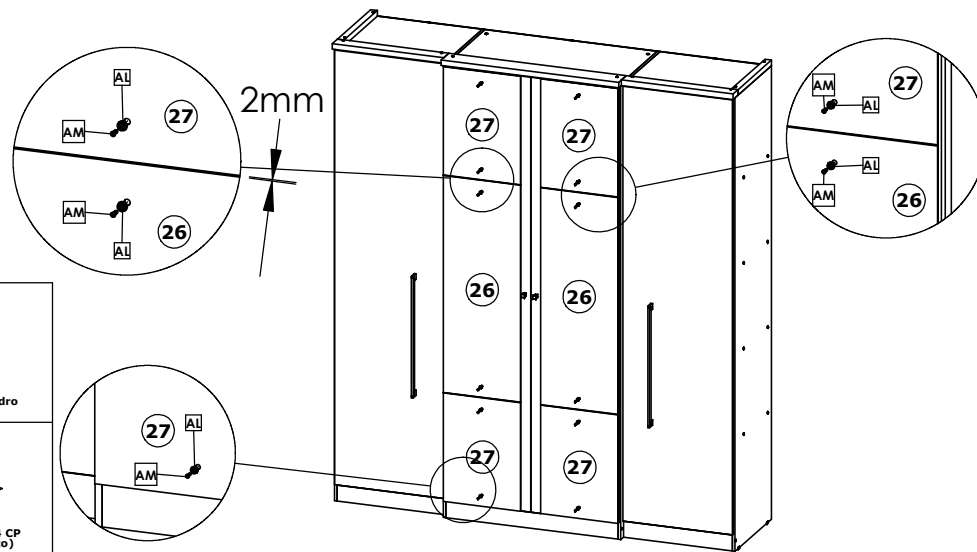

Posicione os Espelhos (26), á 302mm do Topo da Porta (25) e paralelo a lateral da Porta (25).

Logo fixe os Espelhos (26), com Parafusos [AN] e Suporte Vidro Pino [AM] /

Position Mirrors (26), 302mm from Top of Door (25) and parallel to side of Door (25).

Then secure the Mirrors (26), with Screws [AN] and Mount Glass Pin [AM] /

Coloque los espejos (26), a 302mm de la parte superior de la puerta (25) y paralelo al lateral de la puerta (25).

Luego fije los Espejos (26), con Tornillos [AN] y Soporte Vidro Pino [AM].

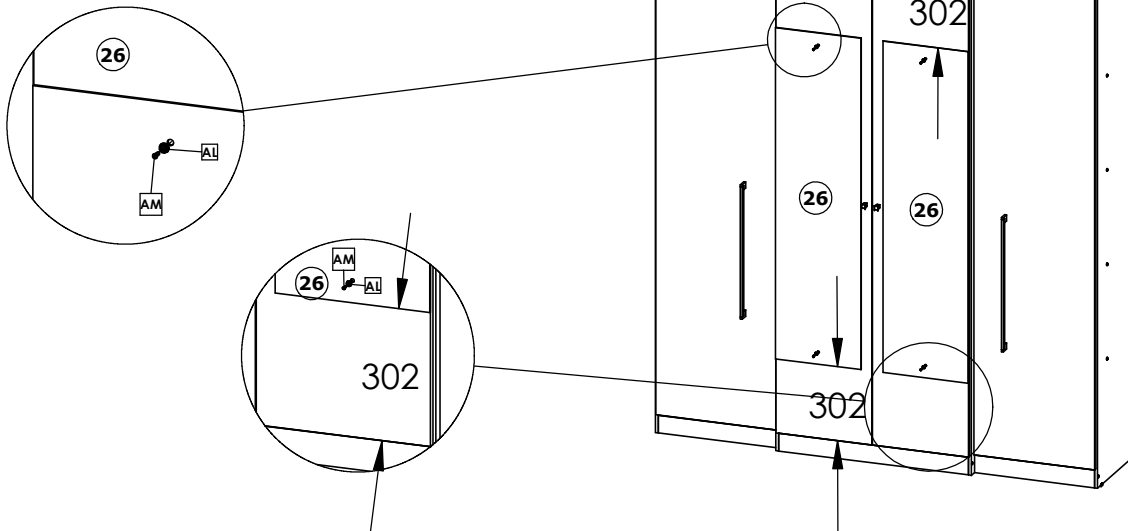

AL	4
Suporte Pino Vidro 25678	
AM	4
Parafuso 3,5x14 CP (Zincado Branco) 34125	

Splendore New

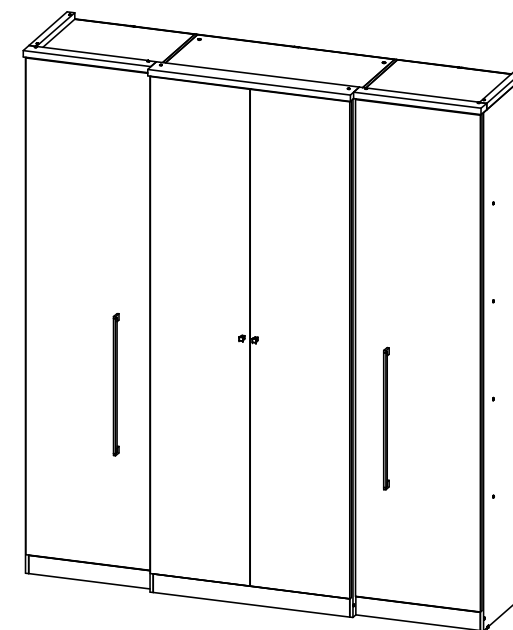

Roupeiro Splendore New 4 Portas / Wardrobe Splendore New 4 Doors / Ropero Splendore New 4 Puertas

Splendore New Glass

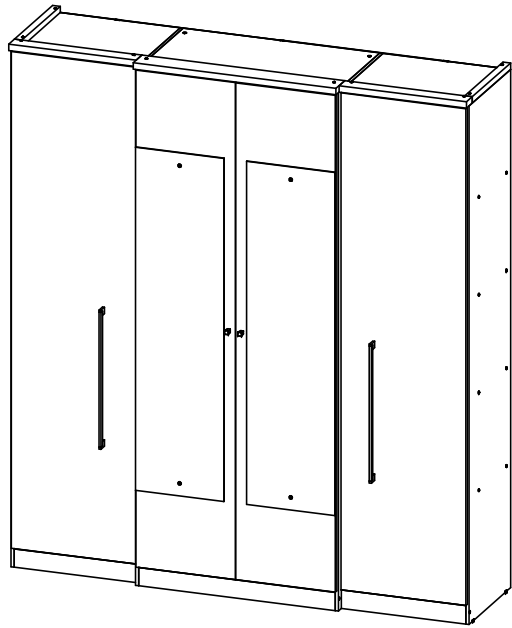

Splendore New

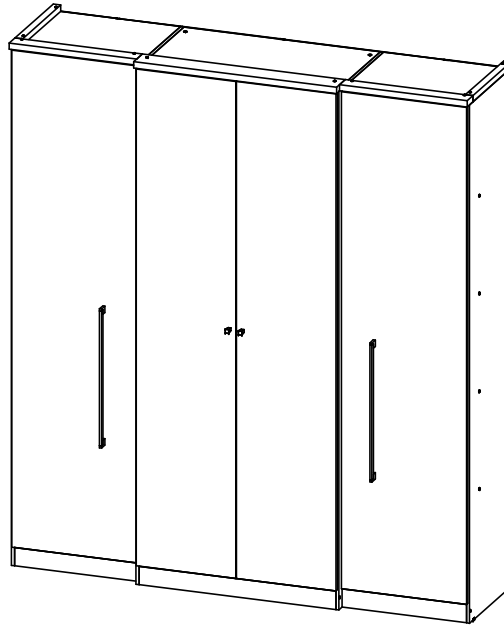

Splendore New Glass

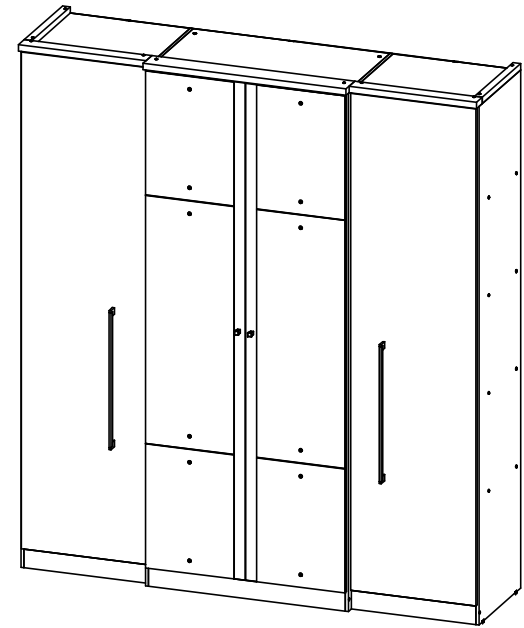



Roupeiro Splendore New 4 Portas / Wardrobe Splendore New 4 Doors / Ropero Splendore New 4 Puertas

quarta-feira, 22 de junho de 2022

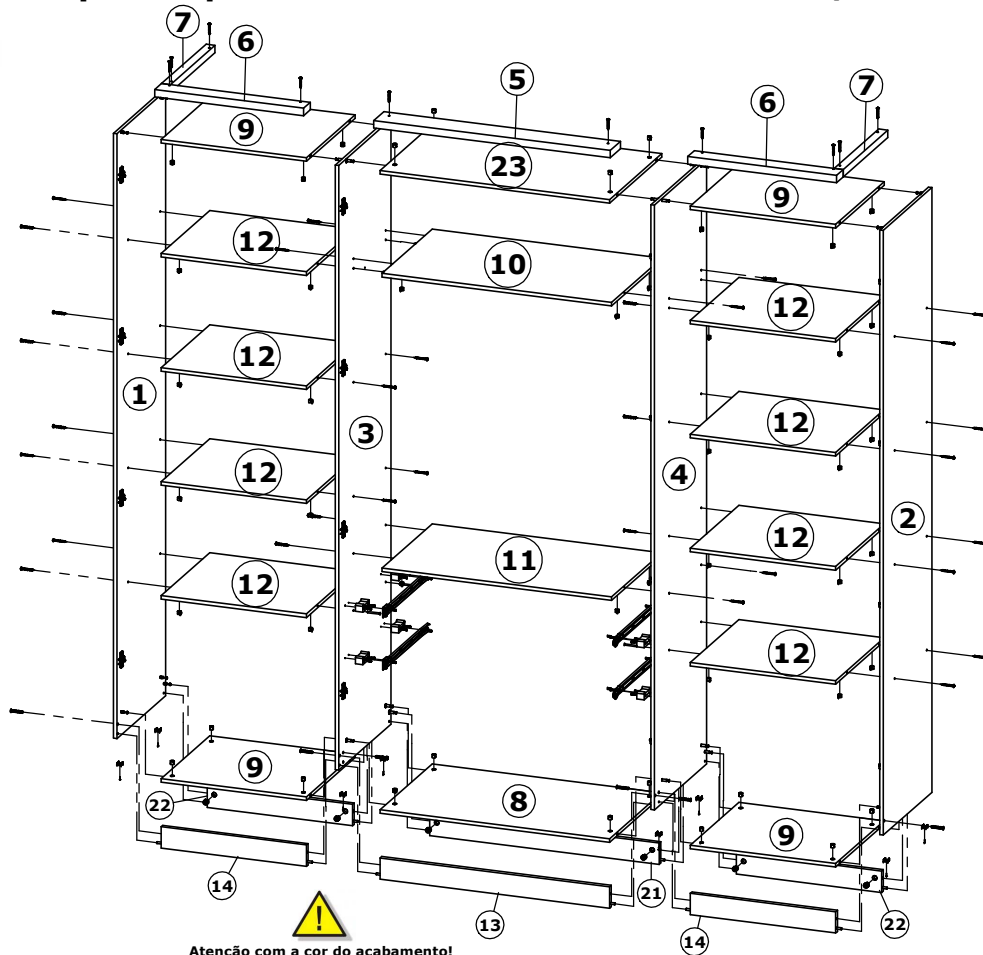

Peça Pieze Pieza	Preto Stv	Descrição	Description	Descripción	Qtd Qty Cant	Compr Length Largo	Larg. Width Ancho	Esp. Thickness Espesor
1	P19083	Lateral Esquerda	Left Panel	Lateral Izquierda	1	2036	436	12
2	P19085	Lateral Direita	Right Panel	Lateral Derecha	1	2036	436	12
3	P19077	Divisão Esquerda	Left Division	Division Izquierda	1	2036	468	12
4	P19082	Divisão Direita	Right Division	Division Derecha	1	2036	468	12
5	P19079	Moldura Sup. Central	Central Beam Frame	Marco suprimido	1	803	92	25
6	P19081	Moldura Sup. Menor	Smallest Sup. Frame	Marco Sup. Menor	2	505	60	25
7	P19080	Moldura Sup. Lateral	Side Superstructure	Lámpara Sup. Lateral	2	401	30	25
8	P16390	Tampo Inf Central	Top Inf Central	Tapa Inf Central	1	779	468	12
9	P16387	Tampo Sup/Inf Lat.	Sup / Inf Lateral Top	Tapa Sup / Inf Lateral	4	493	436	12
10	P16384	Tampo Intermediário	Intermediate Top	Tapa	1	779	450	12
11	P16383	Tampo (1ld s/Pintura)	Cover (One ld painted)	Tapa (1ld s/ pintura)	1	779	450	12
12	P16388	Tampo Lateral	Lateral Top	Tapa lateral	8	493	436	12
13	P19078	Frente Pé Central	Front Center Foot	Frente Pie Central	1	779	72	15
14	P19084	Frente Pé Lateral	Front Side Foot	Del lado derecho	2	493	72	15
15	P16392	Frente Gaveta	Drawer Frontal	Frente del Cajón	2	723	149	12
16	P16060	Lateral Gaveta	Side Drawer	Lateral del Cajón	4	385	88	12
17	P16393	Fundo Gaveta	Bottom Drawer	Fondo del Cajón	2	704	403	2,5
18	P16391	Traseiro Gaveta	Rear Drawer	Traseo del Cajón	2	704	88	12
19	P16381	Fundo Central	Central Fund	Fondo Central	2	1964	392	2,5
20	P16382	Fundo Lateral	Lateral Background	Fondo Lateral	4	1964	249	2,5
21	P14731	Traseiro Pé Central	Rear Center Foot	Trasero Pie Central	1	779	72	15
22	P14728	Traseiro Pé Lateral	Rear Foot	Trasero Pie Lateral	2	493	72	15
23	P17543	Tampo Sup Central	Top Sup Central	Tapa Sup Central	1	779	468	12
24	P19075	Porta Lateral	Side Door	Puerta Lateral	2	1952	495	15
25	P19076	Porta Central	Central Door	Puerta Central	2	1952	394	15



Atenção com a cor do acabamento!
Em caso de assistência solicitar o código de acordo com a cor da peça/
Pay attention to the color of the finish!
In case of assistance request the code according to the color of the part/
Atención con el color del acabado!
En caso de asistencia solicitar el código de acuerdo con el color de la pieza.

Cod. Qnt.

A 10 Parafuso Bifix 33160	B 24 Parafuso 3,5x12 CP 33297	C 2 Puxador Ponto Canaan 34530 - Cromado	D 6 Parafuso Soberbão 7x40 25691	E 76 Parafuso 4,0x12 CC 30189	F 36 Parafuso 4,0x50 CF 32048 - Zincado Preto	G 4 Parafuso 4,0x50 CC 32977 - Zincado Preto	H 28 Cavilha 6x30 24603	I 2 Parafuso 3,5x25 CF 24648 (Puxador Ponto Canaan)
J 10 Parafuso 4,0x35 CF 29815	K 4 Parafuso 3,5x30 CC 36722 (Emb. c/ Sup. Cabideiro)	L 4 Parafuso 3,5x30 CF 25700 (Puxador Citrino)	M 18 Parafuso 3,5x14 CP 34125 - Zincado Branco	N 10 Paraf. Minifix Haste Dupla 30198	O 30 Presilha Fundo 24099	P 130 Prego 10x10 20179	Q 8 Sapata Plástica 12x12 38762 - Preto	R 2 SACHE de cola 10g 25676
S 6 Tambor Minifix 15mm 22388	T 24 Tambor Minifix 12mm 30182	U 24 Tampa Tambor Minifix 36012 - Linho	V 4 Tampa Soberbão 38763 - Preto	W 2 Suporte Triangular 30094	X 40 Porca Cilíndrica 36008 - Linho	Y 8 Cantoneira Plástica 36010 - Linho	Z 16 Calço p/ Dobradilha 23273	AA 16 Dobradilha Baixa 23271
AB 2 Suporte Cabideiro 36611	AC 1 Adesivo Logotipo THB 31363	AD 2 Correção Macho Dir. 21611	AE 2 Correção Macho Esq. 21611	AF 2 Correção Fêmea Esq. 21611	AG 2 Correção Fêmea Dir. 21611	AH 1 Cab. Oblongo 772mm 35138	AI 3 Perfil H 1964mm 34804 - Champagne	AJ 2 Puxador Citrino 512mm 24904 - Alumínio 28717 - Ponteira Crom.
AK 8 Distanciator 25mm 37492	-	-	-	-	-	-	-	-

Espelhos Splendore New Plus Glass

26	34849	Espelho Maior	DoorLarge Mirror	Espejo Mayor	2	974	350	3
27	34850	Espelho Menor	Small Mirror	Espejo Menor	4	487	350	3

Espelhos Splendore New Glass

27	30938	Espelho Maior	DoorLarge Mirror	Espejo Mayor	2	1348	350	3
----	-------	---------------	------------------	--------------	---	------	-----	---



Ferramentas necessárias (Não fornecidas)
Tools Required (Not Provided)
Herramientas necesarias (no incluidas)



Medidas em mm



AK 8 Distanciator 25mm 37492	-	-	-	-	-	-	-
-----------------------------------	---	---	---	---	---	---	---

Roupeiro Splendore New 4 Portas / Wardrobe Splendore New 4 Doors / Ropero Splendore New 4 Puertas

1º Passo / Step / Paso

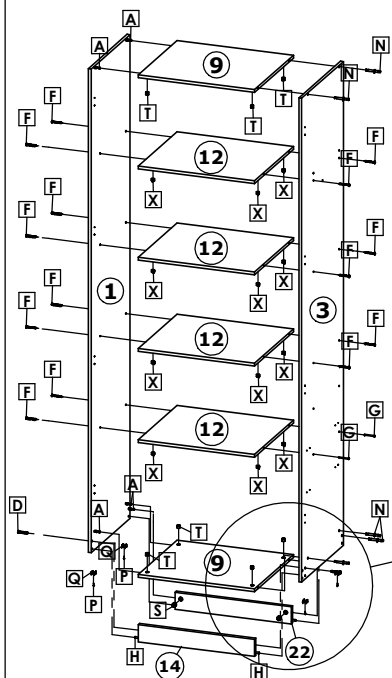

Inicie a Montagem pelas Torres Laterais, fixando Laterais ① e ②, Divisões ③ e ④, nos Tamos ⑨ e ⑫, com Parafusos F, D, N e A/

Start the Assembly by the Side Towers, fixing Side ① and ②, Divisions ③ and ④, on Tops ⑨ and ⑫, with Screws F, D, N and A/

Inicie el Montaje por las Torres Laterales, fijando Laterales ① y ②, Divisiones ③ y ④, en los Tableros ⑨ y ⑫, con Tornillos F, D, N y A/

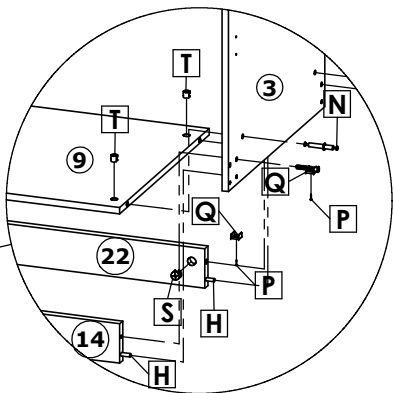

2º Passo / Step / Paso

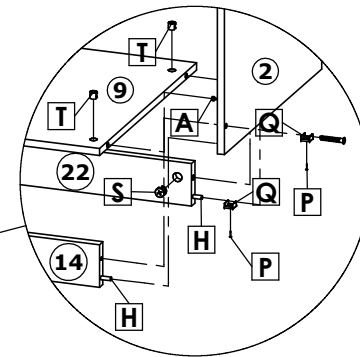
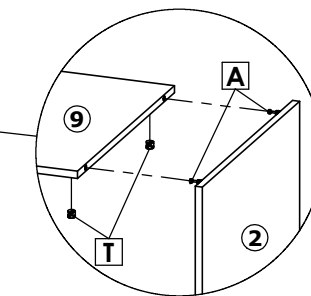
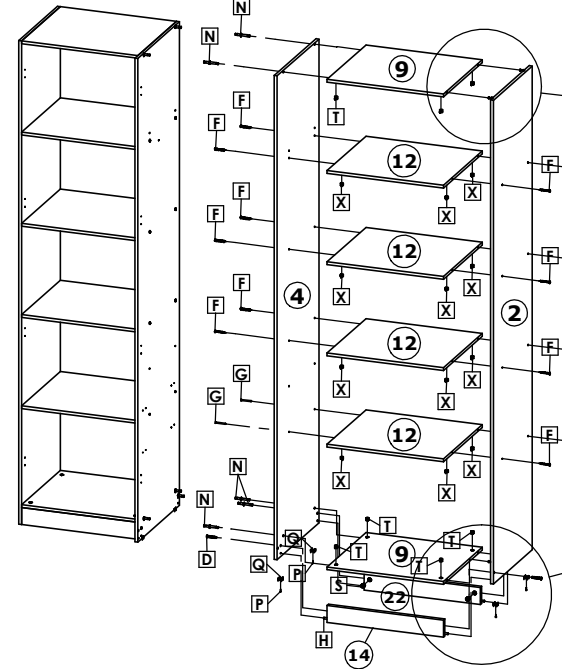

3º Passo / Step / Paso

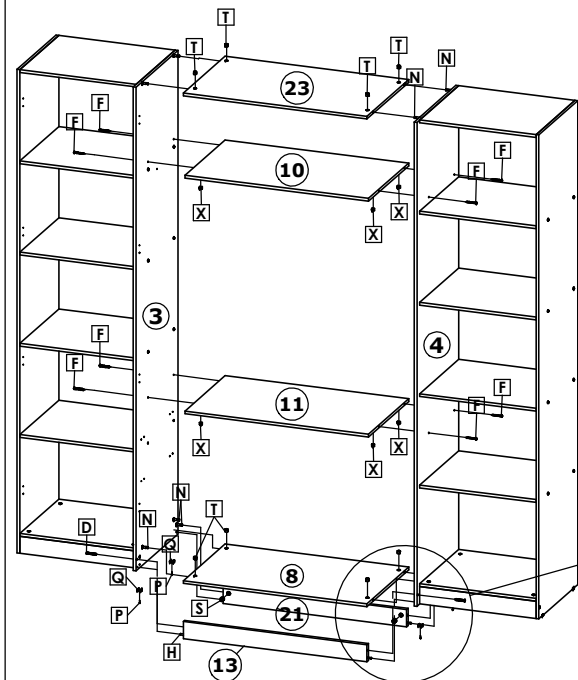

Após a montagem das duas Torres Laterais, fixar os tamos Centrais ②③, ⑧, ⑩ e ⑪ com Parafusos N, F e Tambor T. Já a Frente Pé ⑬ e Traseiro Pé ⑳①, fixar com Parafusos D, N e Tambor S/

After the assembly of the two Side Towers, fix the Central tops ②③, ⑧, ⑩ and ⑪ with Screws N, F and Drum T. Already the Front Foot ⑬ and Rear Foot ⑳①, fix with Screws D, N and Drum S/

Después del montaje de las dos Torres Laterales, fijar las encimeras Centrales ②③, ⑧, ⑩ y ⑪ con Tornillos N, F y Tambor T. En la parte frontal del pie ⑬ y trasero pie ⑳①, fijar con tornillos D, N y tambor S/

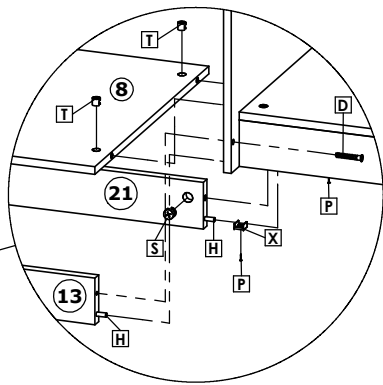

4º Passo / Step / Paso

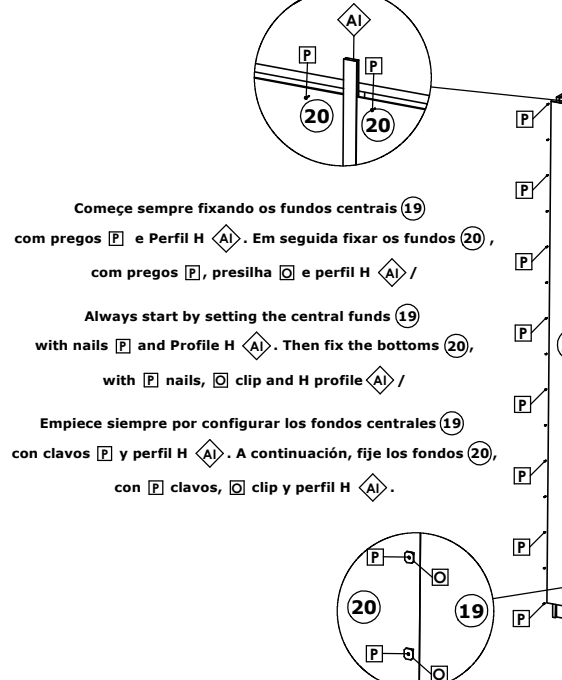

Comece sempre fixando os fundos centrais ⑱ com pregos P e Perfil H A. Em seguida fixar os fundos ⑳, com pregos P, presilha Q e perfil H A/

Always start by setting the central funds ⑱ with nails P and Profile H A. Then fix the bottoms ⑳, with P nails, Q clip and H profile A/

Espiece siempre por configurar los fondos centrales ⑱ con clavos P y perfil H A. A continuación, fije los fondos ⑳, con P clavos, Q clip y perfil H A/

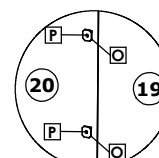
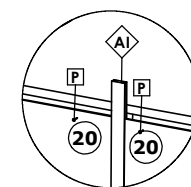

Roupeiro Splendore New 4 Portas / Wardrobe Splendore New 4 Doors / Ropero Splendore New 4 Puertas

5º Passo / Step / Paso

Após posicionar as Molduras Superior ⑤, ⑥ e ⑦, fixa-las com Parafuso J /
 After positioning the Top Frames ⑤, ⑥ and ⑦, secure them with Screw J /
 Después de colocar los Marcos Superior ⑤, ⑥ y ⑦, fijarlos con Tornillo J.

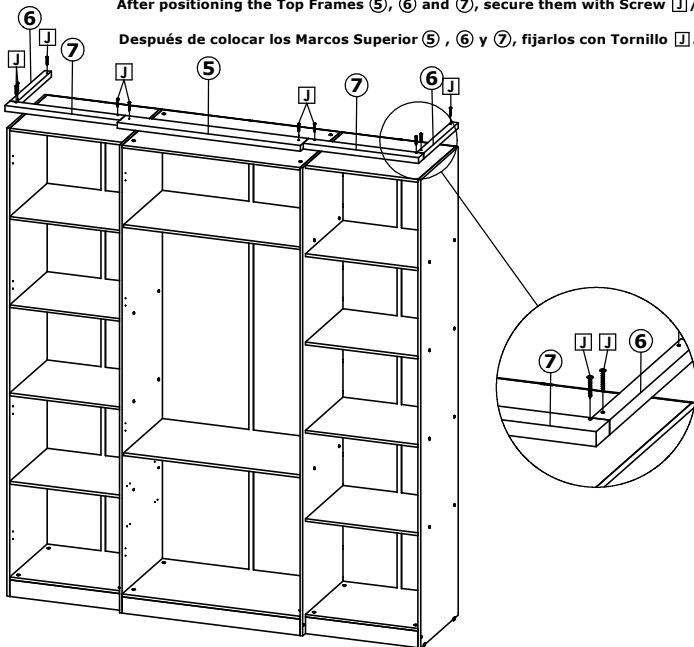

6º Passo / Step / Paso

Montagem das Gavetas / Mounting the Drawers / Montaje del Cajón.

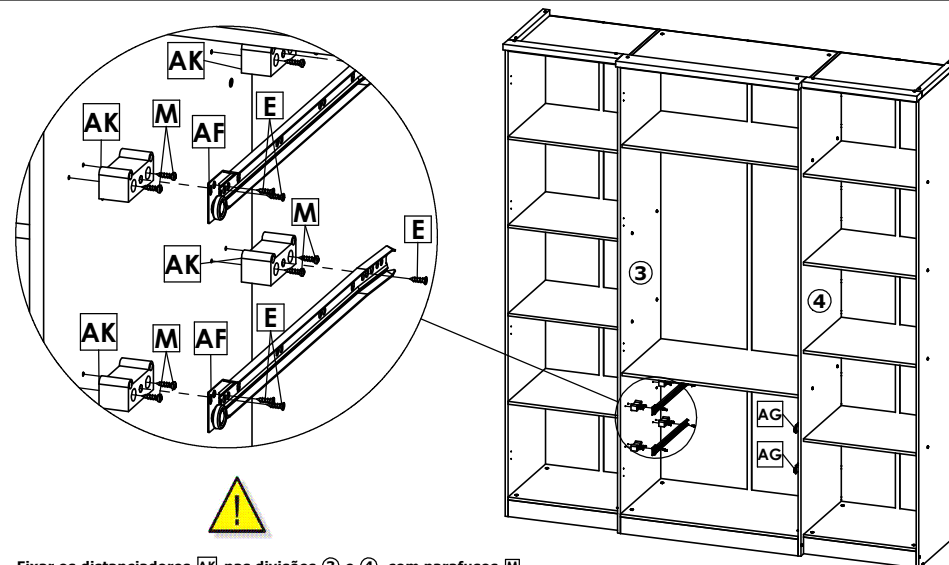
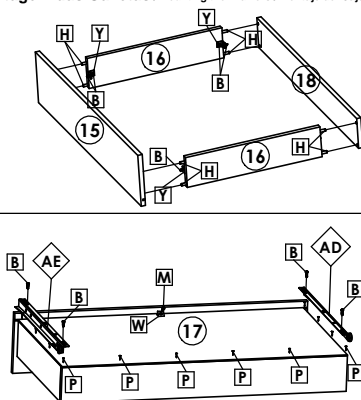

Fixar os distanciadores AK nas divisões ③ e ④, com parafusos M.
 Logo fixar as correijas AF e AG nos distanciadores AK com parafusos E /
 Fix spacers AK in divisions ③ and ④, with screws M.
 Then fix the slides AF and AG on the spacers AK with screws E /
 Fije los espaciadores AK en las divisiones ③ y ④, con tornillos M.
 Luego fije las diapositivas AF y AG en los espaciadores AK con tornillos E.

7º Passo / Step / Paso

Peso Suportado / Weight supported / peso que soporta



Fixar Suportes de Cabideiro AB, com Parafuso K nas Divisões ③ e ④ /
 Attach Clothes Rack AB with Screw K in Divisions ③ and ④ /
 Fijar Soportes de Cabezal AB, con Tornillo K en las Divisiones ③ y ④.

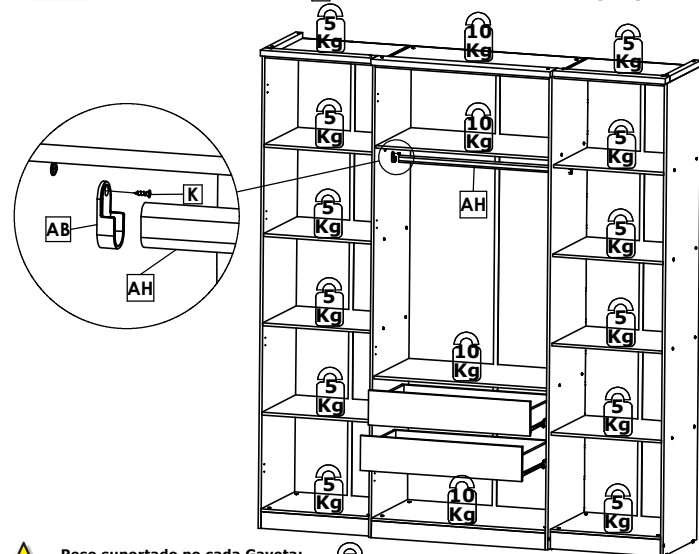

Peso suportado po cada Gaveta:
 Weight supported by each Drawer:
 Peso suportado por cada Cajón:



Montagem Portas Splendore New / Splendore New Doors / Puertas Splendore New

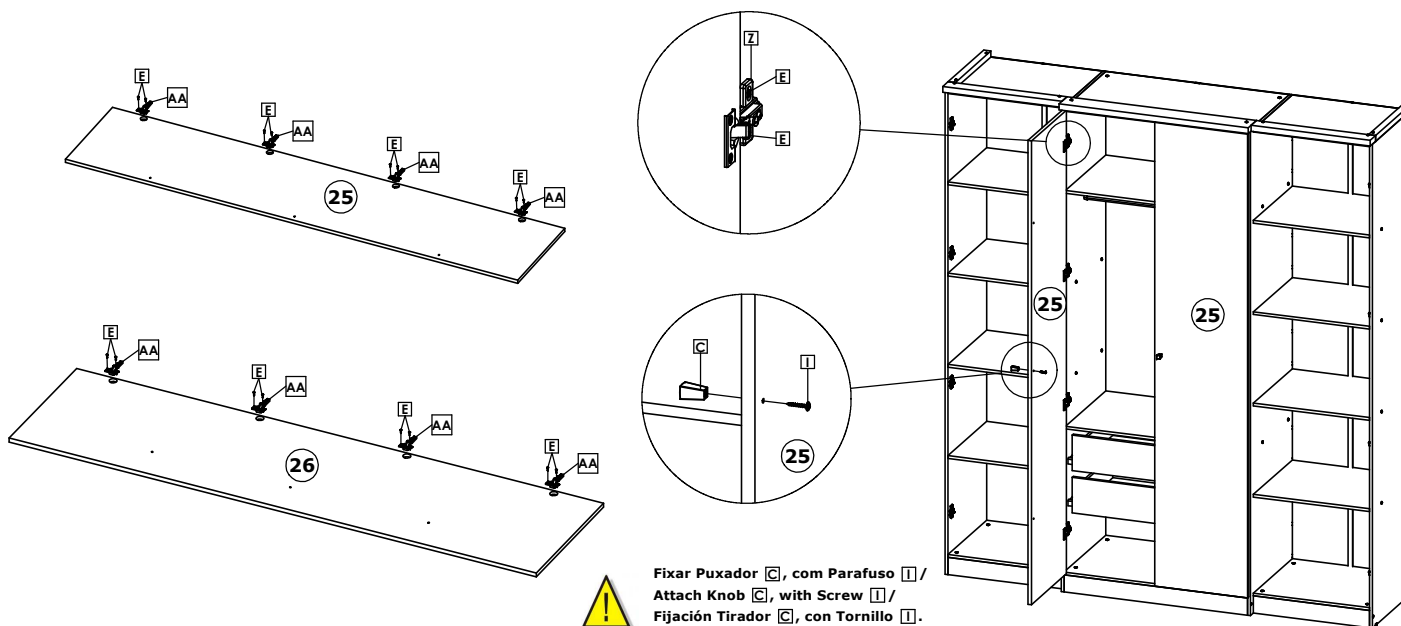

Fixar Puxador C, com Parafuso I /
 Attach Knob C, with Screw I /
 Fijación Tirador C, con Tornillo I.

Roupeiro Splendore New 4 Portas / Wardrobe Splendore New 4 Doors / Ropero Splendore New 4 Puertas

Montagem Portas Splendore New/ Splendore New Doors / Puertas Splendore New

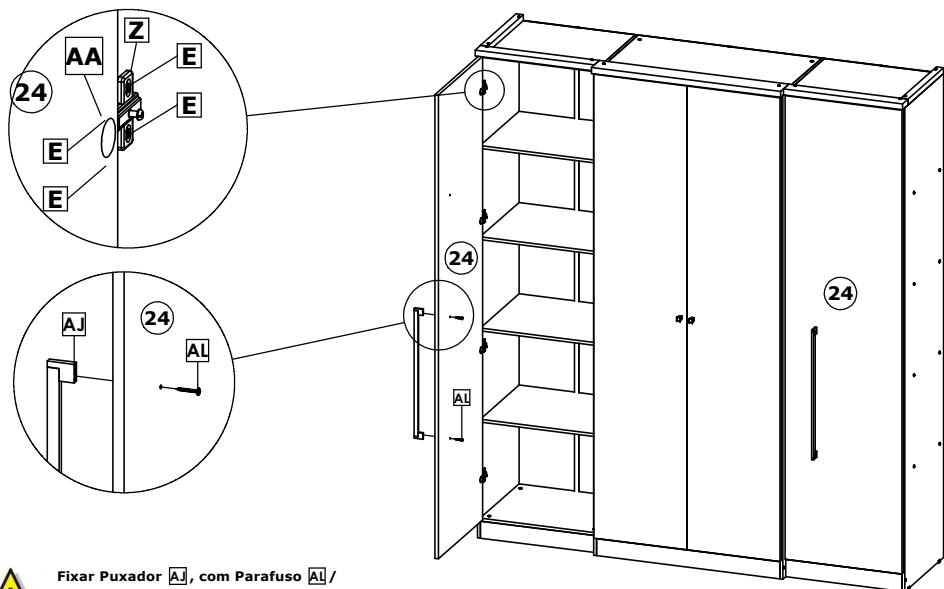

Fixar Puxador [AJ], com Parafuso [AL] /
Attach Knob [AJ], with Screw [AL] /
Fijación Tirador [AJ], con Tornillo [AL].

Inicie a montagem alinhando os Espelhos Superior (27), com a Lateral e topo da Porta (25).

Logo inserir os Espelhos (26) e (27), fixando-os com Parafusos [AM] e Suporte Vidro Pino [AL], deixando entre cada Espelho um espaçamento de 2mm /
Start the assembly by aligning the Top (27), Mirrors with the Side and Top of Door (25).
Then insert Mirrors (26) and (27), securing them with Screws [AM] and Glass Pin Support [AL], leaving between each Mirror a spacing of 2mm /

Inicie el montaje alineando los espejos (27) superior, con el lateral y la parte superior de la puerta (25).

Luego inserte los Espejos (26) y (27), fijándolos con Tornillos [AM] y Soporte Vidro Pino [AL], dejando entre cada espejo un espaciamento de 2mm.

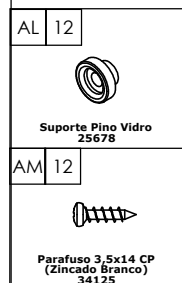
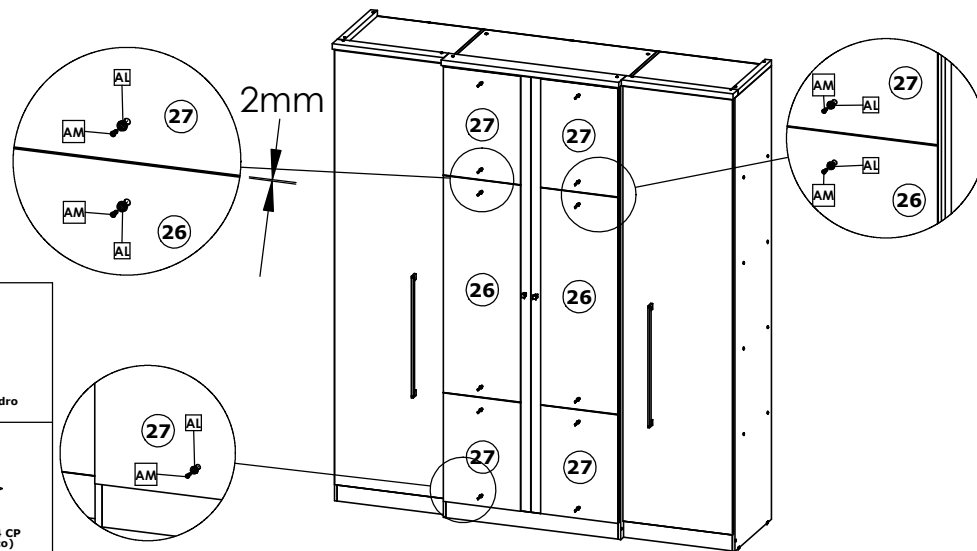

Posicione os Espelhos (26), á 302mm do Topo da Porta (25) e paralelo a lateral da Porta (25).

Logo fixe os Espelhos (26), com Parafusos [AN] e Suporte Vidro Pino [AM] /

Position Mirrors (26), 302mm from Top of Door (25) and parallel to side of Door (25).

Then secure the Mirrors (26), with Screws [AN] and Mount Glass Pin [AM] /

Coloque los espejos (26), a 302mm de la parte superior de la puerta (25) y paralelo al lateral de la puerta (25).

Luego fije los Espejos (26), con Tornillos [AN] y Soporte Vidro Pino [AM].

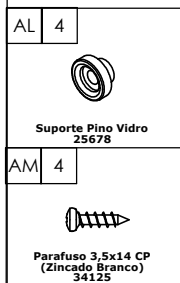
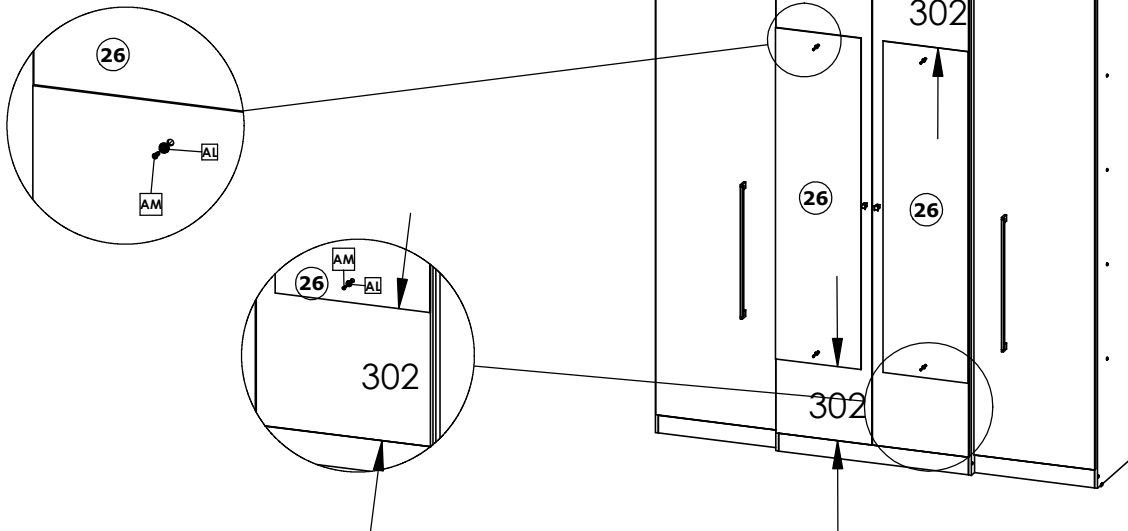

Splendore New

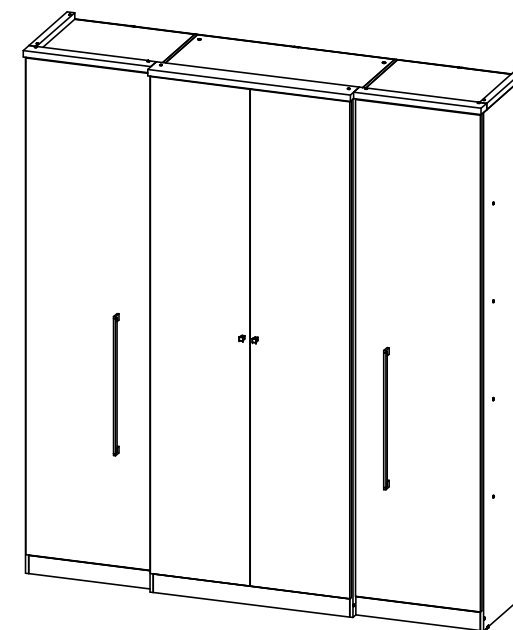

Roupeiro Splendore New 4 Portas / Wardrobe Splendore New 4 Doors / Ropero Splendore New 4 Puertas

Splendore New Glass

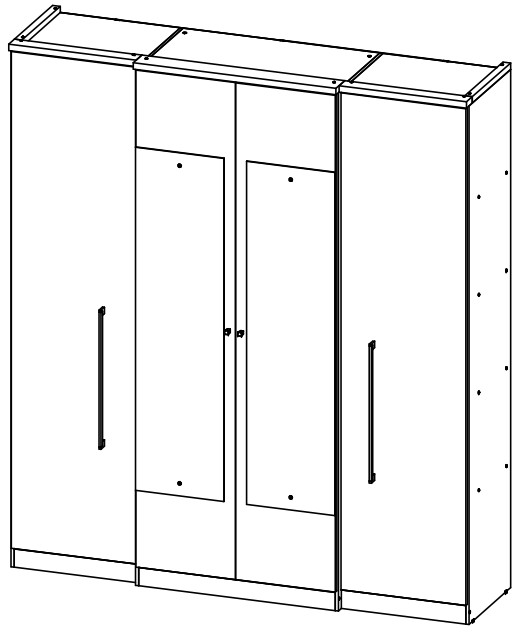

Splendore New

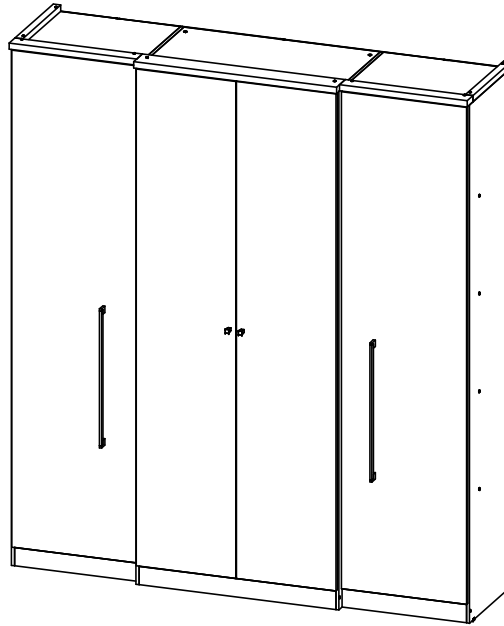

Splendore New Glass

